

# Heavy-Duty Industrial Panel PC

## IPPC17A9-RE / IPPC19A9-RE



### Highlight

- 2nd/3rd Generation Intel® Core™ processor
- 12V~24V wide-range DC-in power input
- Auto brightness adjustment w/ front dimming sensor
- Front keypads for OSD adjustment and function keys
- Two PCI expansion slots
- IP65 front-panel protection

### Features



Aluminum front bezel



Auto dimming sensor



Brightness and volume control  
 F1~F5 function key  
 Network and Serial port working  
 LED indication

### I/O View



IPPC17A9-RE I/O



IPPC19A9-RE I/O

- 01 Stainless Steel Panel PC
- 02 All-in-one Panel PC with Riser Card Expansion
- 03 Compact Panel PC
- 04 Heavy-Duty Industrial Panel PC
- 05 iBASE Medical Solution
- 06 ARM-Based Panel PC
- 07 ARM-Based HMI

# Heavy-Duty Industrial Panel PC

## Specification

Model No.	IPPC17A9-RE	IPPC19A9-RE
<b>System</b>		
Processor	Intel® Core i3-2340UE 1.3 GHz	
System Memory	2x DDR3 1333 SO-DIMM up to 16GB	
<b>External I/O</b>		
USB	4x USB connector; USB1/2 USB2.0 only, USB3/4 USB3.0	
Serial/Parallel	3x DB9 for COM1/2(RS-232/422/485), COM 3 (RS-232 only)	
Audio	1x Line-out micro jack 1x Mic-in micro jack	
Graphics	1x DVI-I	
LAN	2x RJ45 for GbE LAN	
Digital I/O	1x Digital I/O	
Keyboard/Mouse	None	
Membrane Control	None	
Power	1x 3pin DC power connector	
<b>Storage Space</b>		
HDD	1x 2.5" SATA	
Movable Slot	1x CFAST slot	
<b>Expansion</b>		
Onboard Expansion Bus	2x Mini-PCIe half/full size	
Expansion Slot	2x PCI slot	
<b>Display</b>		
Display Type	17" TFT-LCD	19" TFT-LCD
Max. Resolution	1280 x 1024	
Max. Color	16.7M	
Luminance (cd/m2)	350	
View Angle (H°/V°)	170/170	170/160
Contrast	800:1	1000:1
Backlight Lifetime(hrs)	50000	
<b>Touch Screen</b>		
Type	Resistive	
Interface	USB	
Light Transmission (%)	81	
<b>Power</b>		
Power Input	12~24V DC input	
<b>Mechanical</b>		
Construction	Aluminum & SPCC	
IP Rating	IP65 front bezel	
Mounting	Panel and VESA 75x75mm / 100x100mm	
Dimensions (mm)	430 x 365 x 109.5	465 x 390 x 109.5
Net Weight (kgs)	9.2kgs	9.7kgs
<b>Environment</b>		
Operating Temperature(°C)	0°C ~ 45°C	
Storage Temperature(°C)	-20°C ~ 80°C	
Storage Humidity	5%~90% @ 45°C (non-condensing)	
Certification	CE/FCC Class B	
Operating System Support	Windows Embedded Standard 7, Windows 7 Pro for Embedded	

# Heavy-Duty Industrial Panel PC

## Dimensions

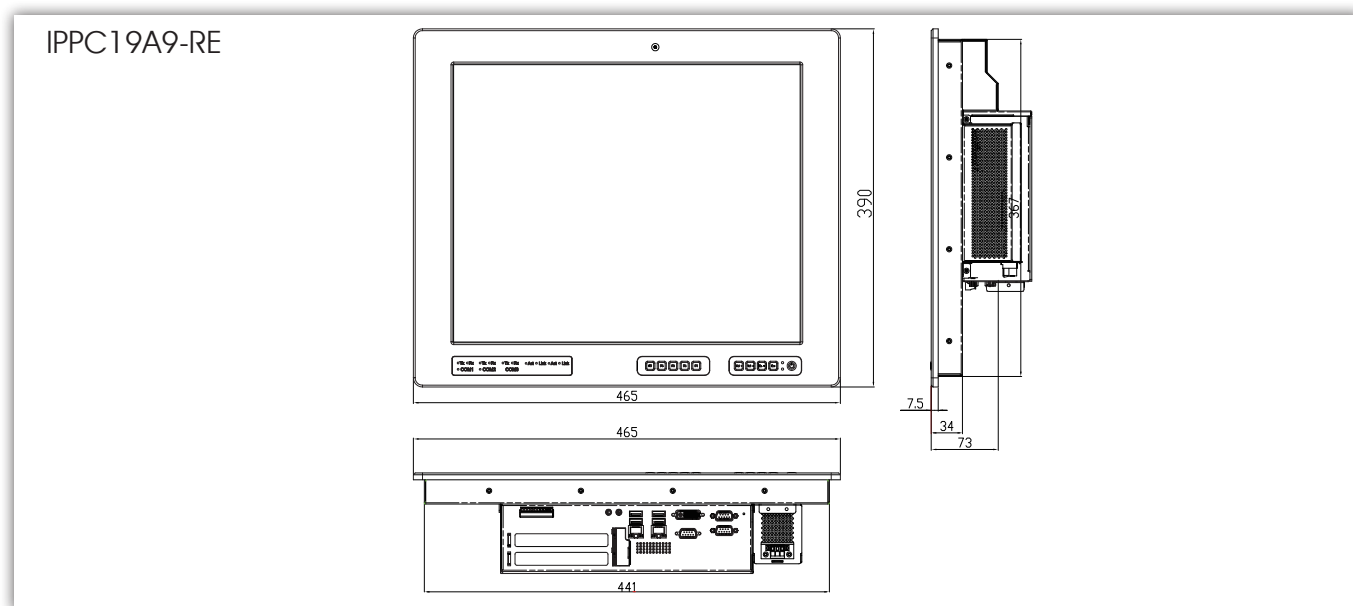
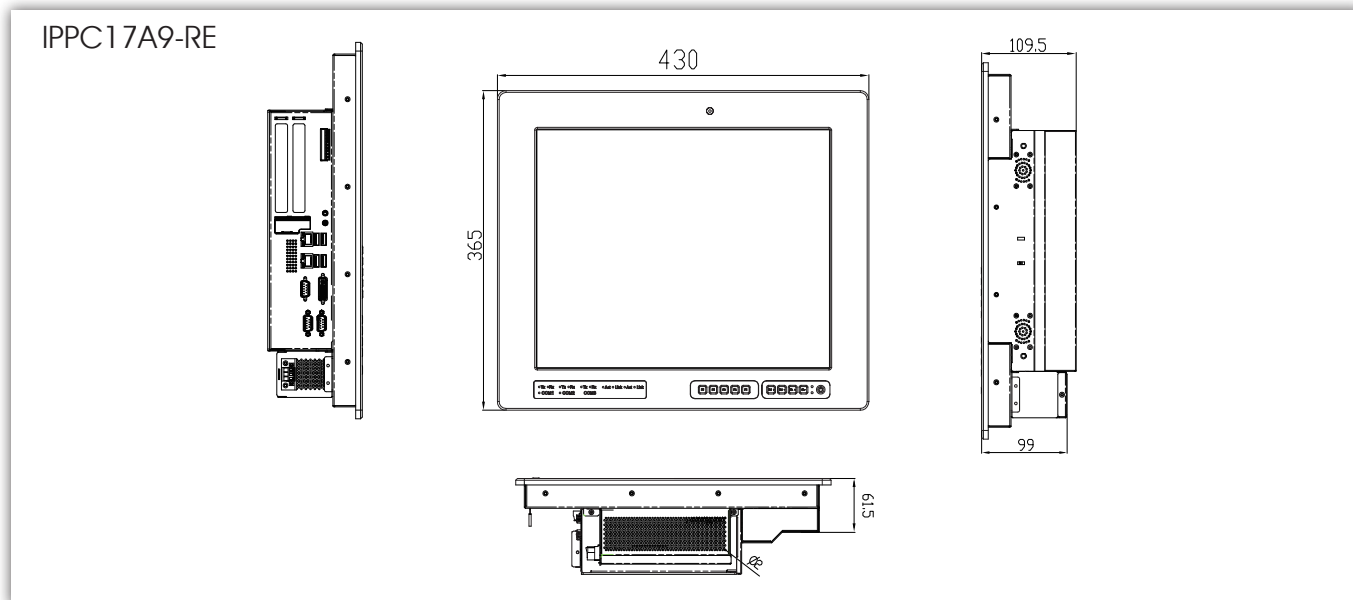

## Ordering Information

IPPC17A9-RE	17" Modular Panel PC with resistive touch Intel® Core™ i3-2340UE 1.3GHz CPU, 4GB DDR3-1333 SO-DIMM, 320G HDD, 12V-24V wide range DC input, w/o power adaptor
IPPC19A9-RE	19" Modular Panel PC with resistive touch Intel® Core™ i3-2340UE 1.3GHz CPU, 4GB DDR3-1333 SO-DIMM, 320G HDD, 12V-24V wide range DC input, w/o power adaptor
Power adaptor	AC 90~240V input, 12V DC output 84W power adaptor IBASE P/N: A005PS084W0050000P