

# AEC-6637

---

Fanless Embedded Box PC

User's Manual 3<sup>rd</sup> Ed

## Copyright Notice

---

This document is copyrighted, 2015. All rights are reserved. The original manufacturer reserves the right to make improvements to the products described in this manual at any time without notice.

No part of this manual may be reproduced, copied, translated, or transmitted in any form or by any means without the prior written permission of the original manufacturer. Information provided in this manual is intended to be accurate and reliable. However, the original manufacturer assumes no responsibility for its use, or for any infringements upon the rights of third parties that may result from its use.

The material in this document is for product information only and is subject to change without notice. While reasonable efforts have been made in the preparation of this document to assure its accuracy, AAEMON assumes no liabilities resulting from errors or omissions in this document, or from the use of the information contained herein.

AAEMON reserves the right to make changes in the product design without notice to its users.

## Acknowledgement

---

All other products' name or trademarks are properties of their respective owners.

- Microsoft Windows is a registered trademark of Microsoft Corp.
- Intel, Pentium, Celeron, and Xeon are registered trademarks of Intel Corporation
- Core, Atom are trademarks of Intel Corporation
- ITE is a trademark of Integrated Technology Express, Inc.
- IBM, PC/AT, PS/2, and VGA are trademarks of International Business Machines Corporation.

All other product names or trademarks are properties of their respective owners.

## Packing List

---

Before setting up your product, please make sure the following items have been shipped:

Item	Quantity
● BOXER-6637	1
● RAM thermal pad (1998F15003 x 1, 1998666630 x2, 1998666652 x 1)	4
● Screw package	1
● Wallmount bracket	2
● Product DVD with User's Manual (in pdf) and drivers	1

If any of these items are missing or damaged, please contact your distributor or sales representative immediately.

## About this Document

---

This User's Manual contains all the essential information, such as detailed descriptions and explanations on the product's hardware and software features (if any), its specifications, dimensions, jumper/connector settings/definitions, and driver installation instructions (if any), to facilitate users in setting up their product.

Users may refer to the [AAEON.com](http://AAEON.com) for the latest version of this document.

## Safety Precautions

---

Please read the following safety instructions carefully. It is advised that you keep this manual for future references

1. All cautions and warnings on the device should be noted.
2. All cables and adapters supplied by AAEON are certified and in accordance with the material safety laws and regulations of the country of sale. Do not use any cables or adapters not supplied by AAEON to prevent system malfunction or fires.
3. Make sure the power source matches the power rating of the device.
4. Position the power cord so that people cannot step on it. Do not place anything over the power cord.
5. Always completely disconnect the power before working on the system's hardware.
6. No connections should be made when the system is powered as a sudden rush of power may damage sensitive electronic components.
7. If the device is not to be used for a long time, disconnect it from the power supply to avoid damage by transient over-voltage.
8. Always disconnect this device from any AC supply before cleaning.
9. While cleaning, use a damp cloth instead of liquid or spray detergents.
10. Make sure the device is installed near a power outlet and is easily accessible.
11. Keep this device away from humidity.
12. Place the device on a solid surface during installation to prevent falls
13. Do not cover the openings on the device to ensure optimal heat dissipation.
14. Watch out for high temperatures when the system is running.
15. Do not touch the heat sink or heat spreader when the system is running
16. Never pour any liquid into the openings. This could cause fire or electric shock.

17. As most electronic components are sensitive to static electrical charge, be sure to ground yourself to prevent static charge when installing the internal components. Use a grounding wrist strap and contain all electronic components in any static-shielded containers.
18. If any of the following situations arises, please the contact our service personnel:
  - i. Damaged power cord or plug
  - ii. Liquid intrusion to the device
  - iii. Exposure to moisture
  - iv. Device is not working as expected or in a manner as described in this manual
  - v. The device is dropped or damaged
  - vi. Any obvious signs of damage displayed on the device
19. **DO NOT LEAVE THIS DEVICE IN AN UNCONTROLLED ENVIRONMENT WITH TEMPERATURES BEYOND THE DEVICE'S PERMITTED STORAGE TEMPERATURES (SEE CHAPTER 1) TO PREVENT DAMAGE.**

### **Warning!**



This device complies with Part 15 FCC Rules. Operation is subject to the following two conditions: (1) this device may not cause harmful interference, and (2) this device must accept any interference received including interference that may cause undesired operation.

### **Caution:**

*There is a danger of explosion if the battery is incorrectly replaced. Replace only with the same or equivalent type recommended by the manufacturer. Dispose of used batteries according to the manufacturer's instructions and your local government's recycling or disposal directives.*

### **Attention:**

*Il y a un risque d'explosion si la batterie est remplacée de façon incorrecte. Ne la remplacer qu'avec le même modèle ou équivalent recommandé par le constructeur. Recycler les batteries usées en accord avec les instructions du fabricant et les directives gouvernementales de recyclage.*



## China RoHS Requirements (CN)

产品中有毒有害物质或元素名称及含量

AAEON Embedded Box PC/ Industrial System

部件名称	有毒有害物质或元素					
	铅 (Pb)	汞 (Hg)	镉 (Cd)	六价铬 (Cr(VI))	多溴联苯 (PBB)	多溴二苯醚 (PBDE)
印刷电路板 及其电子组件	○	○	○	○	○	○
外部信号 连接器及线材	○	○	○	○	○	○
外壳	○	○	○	○	○	○
中央处理器 与内存	○	○	○	○	○	○
硬盘	○	○	○	○	○	○
电源	○	○	○	○	○	○

○：表示该有毒有害物质在该部件所有均质材料中的含量均在 SJ/T 11363-2006 标准规定的限量要求以下。

X：表示该有毒有害物质至少在该部件的某一均质材料中的含量超出 SJ/T 11363-2006 标准规定的限量要求。

备注：  
一、此产品所标示之环保使用期限，系指在一般正常使用状况下。  
二、上述部件物质中央处理器、内存、硬盘、电源为选购品。

# China RoHS Requirement (EN)

Poisonous or Hazardous Substances or Elements in Products  
 AAEON Embedded Box PC/ Industrial System

Component	Poisonous or Hazardous Substances or Elements					
	Lead (Pb)	Mercury (Hg)	Cadmium (Cd)	Hexavalent Chromium (Cr(VI))	Polybrominated Biphenyls (PBB)	Polybrominated Diphenyl Ethers (PBDE)
PCB & Other Components	○	○	○	○	○	○
Wires & Connectors for External Connections	○	○	○	○	○	○
Chassis	○	○	○	○	○	○
CPU & RAM	○	○	○	○	○	○
Hard Disk	○	○	○	○	○	○
PSU	○	○	○	○	○	○

O: The quantity of poisonous or hazardous substances or elements found in each of the component's parts is below the SJ/T 11363-2006-stipulated requirement.

X: The quantity of poisonous or hazardous substances or elements found in at least one of the component's parts is beyond the SJ/T 11363-2006-stipulated requirement.

**Note: The Environment Friendly Use Period as labeled on this product is applicable under normal usage only**

# Table of Contents

---

- Chapter 1 - Product Specifications..... 1
  - 1.1 Specifications..... 2
- Chapter 2 – Hardware Information ..... 5
  - 2.1 Dimensions ..... 6
  - 2.2 Jumpers and Connectors ..... 10
  - 2.3 List of Jumpers ..... 12
    - 2.3.1 LVDS Port 1 Backlight Inverter VCC Selection (JP3) ..... 13
    - 2.3.2 LVDS Port 1 Operating VDD Selection (JP5)..... 13
    - 2.3.3 LVDS Port 1 Backlight Lightness Control Mode Selection (JP6)  
13
    - 2.3.4 COM2 Pin8 Function Selection (JP8) ..... 13
    - 2.3.5 Front Panel Connector (JP9) ..... 14
    - 2.3.6 Touch Screen 4/5/8-Wire Selection (JP10) ..... 14
    - 2.3.7 Clear CMOS (JP11) ..... 14
    - 2.3.8 AT/ATX Power Supply Mode Selection (JP12)..... 15
  - 2.4 List of Connectors ..... 16
    - 2.4.1 LVDS Port 1 Inverter/ Backlight Connector (CN1) ..... 18
    - 2.4.2 External +12V Input (CN2) ..... 18
    - 2.4.3 USB2.0 Port 7 and Port 8 (CN3) ..... 19
    - 2.4.4 USB2.0 Port 5 and Port 6 (CN4) ..... 19
    - 2.4.5 USB2.0 Port 3 and Port 4 (CN5) ..... 20
    - 2.4.6 External +5VSB Input (CN6) ..... 20
    - 2.4.7 Audio I/O Port Connector (CN8) ..... 21
    - 2.4.8 CFast Slot (CN9) ..... 22
    - 2.4.9 COM Port 2 Connector (CN11) ..... 23
    - 2.4.10 LPT/ Digital I/O Port Connector (CN12) ..... 25

2.4.11	COM Port 3 Connector (CN13) .....	28
2.4.12	LPC Port Connector (CN14) .....	28
2.4.13	COM Port 4 Connector (CN15) .....	29
2.4.14	UIM Card Module (CN16).....	30
2.4.15	PS/2 Keyboard/Mouse Combo Port Connector (CN17) .....	30
2.4.16	+5VSB Output w/SMBus (CN18).....	31
2.4.17	Touch Screen Connector (CN19).....	31
2.4.18	CPU FAN Connector (CN20) .....	33
2.4.19	+5V Output for SATA HDD (CN22).....	34
2.4.20	Realtek LAN (RJ-45) Port (CN23) .....	34
2.4.21	Intel LAN (RJ-45) Port (CN24).....	35
2.4.22	USB Port 1 and Port 2 (CN25) .....	35
2.4.23	VGA Port (CN26).....	36
2.4.24	COM Port 1 (D-SUB 9) (CN27) .....	37
2.4.25	CFast Slot (CN28).....	37
2.4.26	DDR3 SODIMM Slot (CN29).....	38
2.4.27	Mini Card Slot (CN30).....	38
2.4.28	SATA Port 1 (SATA1).....	40
2.4.29	SATA Port 2 (SATA2).....	41
2.5	CFast™ Card Installation .....	42
2.6	Hard Disk Drive (HDD) Installation .....	45
2.7	Memory Card Installation.....	48
2.8	Wallmount Kit Installation .....	51
<b>Chapter 3 - AMI BIOS Setup.....</b>		<b>52</b>
3.1	System Test and Initialization .....	53
3.2	AMI BIOS Setup.....	54
3.3	Setup Submenu: Main.....	55
3.4	Setup Submenu: Advanced .....	56

3.4.1	Advanced: ACPI Settings.....	58
3.4.1.1	ACPI Settings: RTC Wake Settings .....	60
3.4.2	Advanced: CPU Configuration.....	62
3.4.2.1	CPU Configuration: CPU PPM Configuration .....	64
3.4.3	Advanced: SATA Configuration.....	66
3.4.4	Advanced: AMT Configuration .....	68
3.4.5	Advanced: USB Configuration .....	69
3.4.6	Advanced: H/W Monitor .....	71
3.4.7	Advanced: Super IO Configuration.....	72
3.4.7.1	Super IO Configuration: Serial Port 1 Configuration.	73
3.4.7.2	Super IO Configuration: Serial Port 2 Configuration.	74
3.4.7.3	Super IO Configuration: Serial Port 3 Configuration.	76
3.4.7.4	Super IO Configuration: Serial Port 4 Configuration.	77
3.5	Setup submenu: Chipset.....	78
3.5.1	Chipset: Onboard Device.....	79
3.5.2	Chipset: PCH-IO Configuration .....	80
3.5.3	Chipset: Memory Configuration.....	82
3.5.4	Chipset: Graphic Configuration .....	84
3.6	Setup submenu: Boot.....	86
3.6.1	Boot: BBS Priorities .....	87
3.7	Security.....	88
3.8	Setup submenu: Save & Exit.....	90
<b>Chapter 4 – Drivers Installation .....</b>		<b>91</b>
4.1	Product CD/DVD.....	92
<b>Appendix A - Watchdog Timer Programming.....</b>		<b>96</b>
A.1	Watchdog Timer Programming .....	97
A.2	ITE8728F Watchdog Timer Initial Program .....	100
<b>Appendix B - I/O Information.....</b>		<b>105</b>

B.1	I/O Address Map.....	106
B.2	Memory Address Map.....	108
B.3	IRQ Mapping Chart.....	109
B.4	DMA Channel Assignments.....	110
<b>Appendix C – RAID &amp; AHCI Settings .....</b>		<b>111</b>
C.1	Setting RAID.....	112
C.2	Setting AHCI.....	119

# Chapter 1

---

Product Specifications

## 1.1 Specifications

### System

● Processor		Intel® Core™ i7-3610QE 2.3GHz processor Intel® Core™ i5-3610ME 2.7GHz processor
● System Memory		DDR3 1066/1333/1600 SDRAM SODIMM x 1, Max. 8 GB
● Chipset		Intel® QM77
● Display Interface	VGA	DB-15 x 1
● Storage Device	SSD	Onboard CFast™ x 1
	HDD	2.5" SATA 6.0Gb/s Hard Disk Drive Bay x 1
● Network	LAN	Gigabit Ethernet
	Wireless	Optional by Mini Card
● Front I/O	USB Host	USB 2.0 x 2
	LAN	—
	Serial Port	—
	DIO	—
	Audio	1
	KB/MS	—
	Others	Power ON/OFF Switch x 1, antenna hole x 2
● Rear I/O	USB Host	USB 3.0 x 1
	LAN	RJ-45 x 2
	Serial Port	RS-232 x 3 RS-232/422/485 x 1
	DIO	—
	Audio	—
	KB/MS	—
	Others	Power Input x 1 VGA x 1



● Expansion	PCIe	—
	PCI	—
	MiniCard	1
	Mini PCI	—
	Others	—
● Indicator	Front	Power LED x 1 Hard Disk Drive active LED x 1
	Rear	—
● Power Requirement		9~30V <sub>DC</sub> with 3-pin terminal block
● System Cooling		Passive cooling
● Mounting		Wall-mounted
● Dimension (W x H x D)		212 x 64 x 156 mm (8.36 x 2.52 x 6.2")
● Gross Weight		3.6 kg (7.94 lb)
● Certification	EMC	CE/FCC Class A
	Safety	—
● OS Support		Windows <sup>®</sup> 10 Windows <sup>®</sup> 7 Windows <sup>®</sup> XP Windows <sup>®</sup> XP Embedded Ubuntu 11.10 – Kernel 3.0.0.12-generic

## Environmental

● Operating Temperature	-10 ~ 45°C (14 ~ 113°F) – CFast™ without air flow
	-10 ~ 50°C (14 ~ 122°F) – HDD without air flow
● Storage Temperature	-20 ~ 70°C (-4 ~ 158°F)
● Anti-Vibration	5 G <sub>rms</sub> /5~500 Hz/ operation- CFast™
	1 G <sub>rms</sub> /5~500 Hz/ operation- HDD

- **Anti-Shock** 50G peak acceleration (11 msec duration)- CFast  
20G peak acceleration (11 msec duration)- HDD

# Chapter 2

---

Hardware Information

## 2.1 Dimensions

### A1M/A2M Version

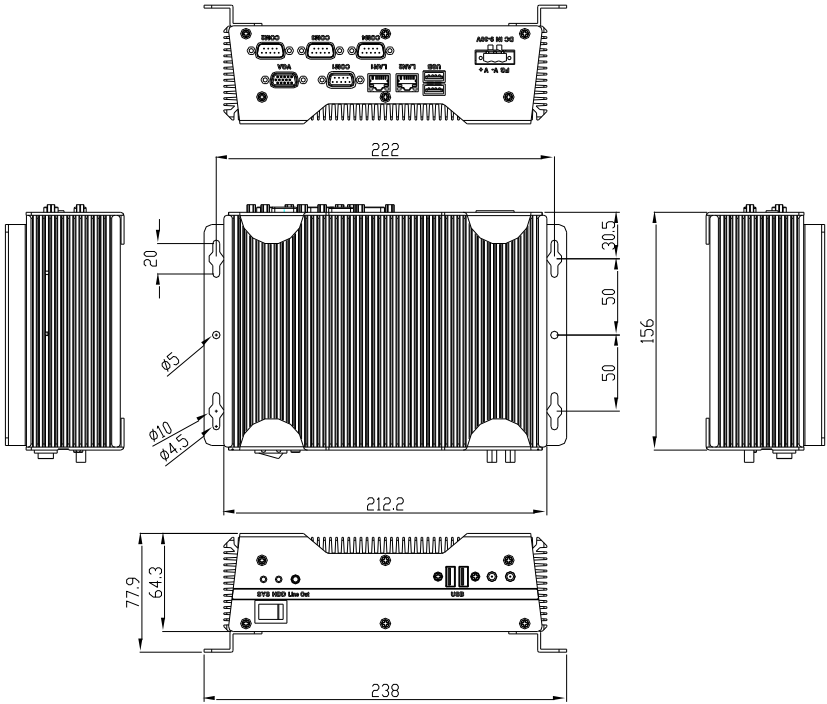

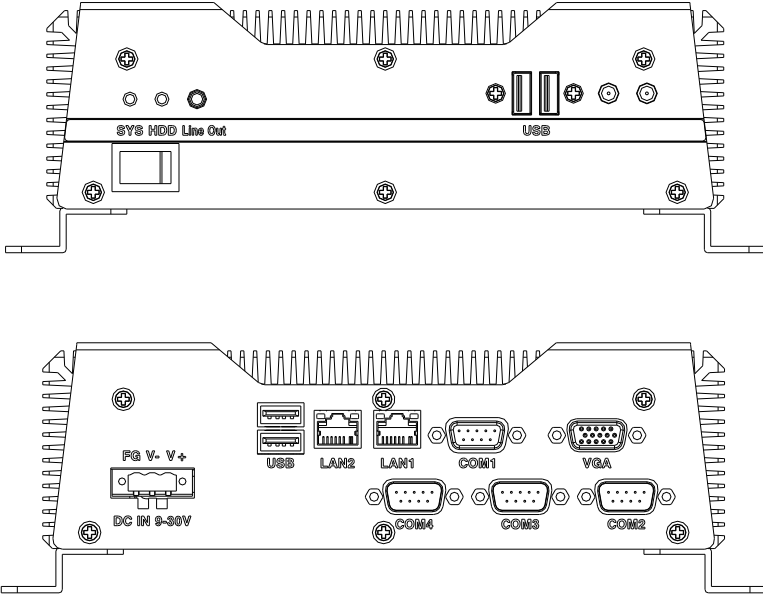

### C1/C2 Version

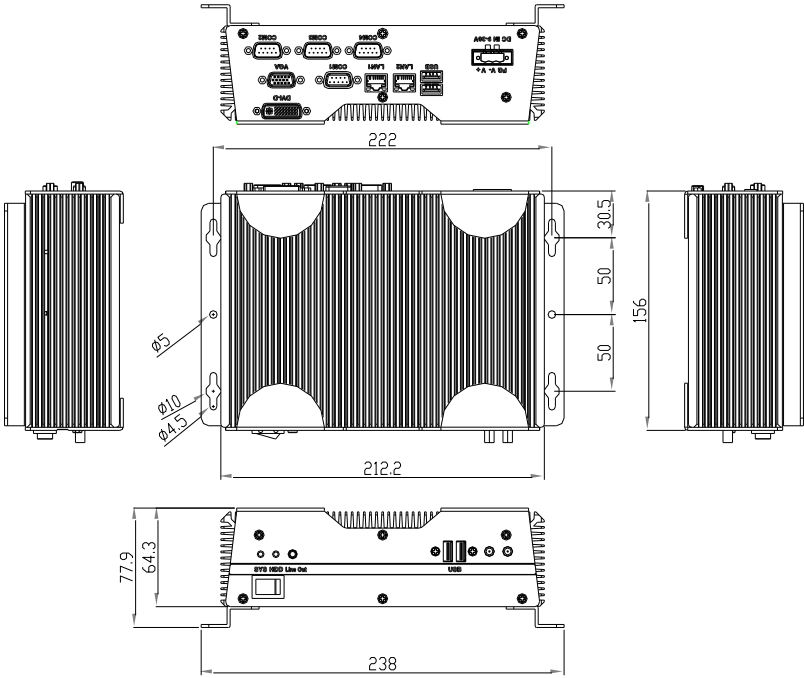

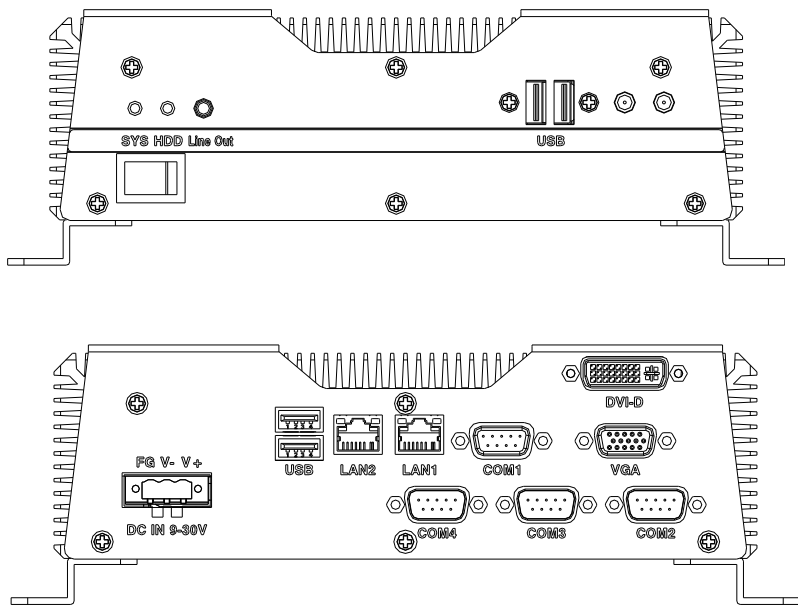

## 2.2 Jumpers and Connectors

### Component Side

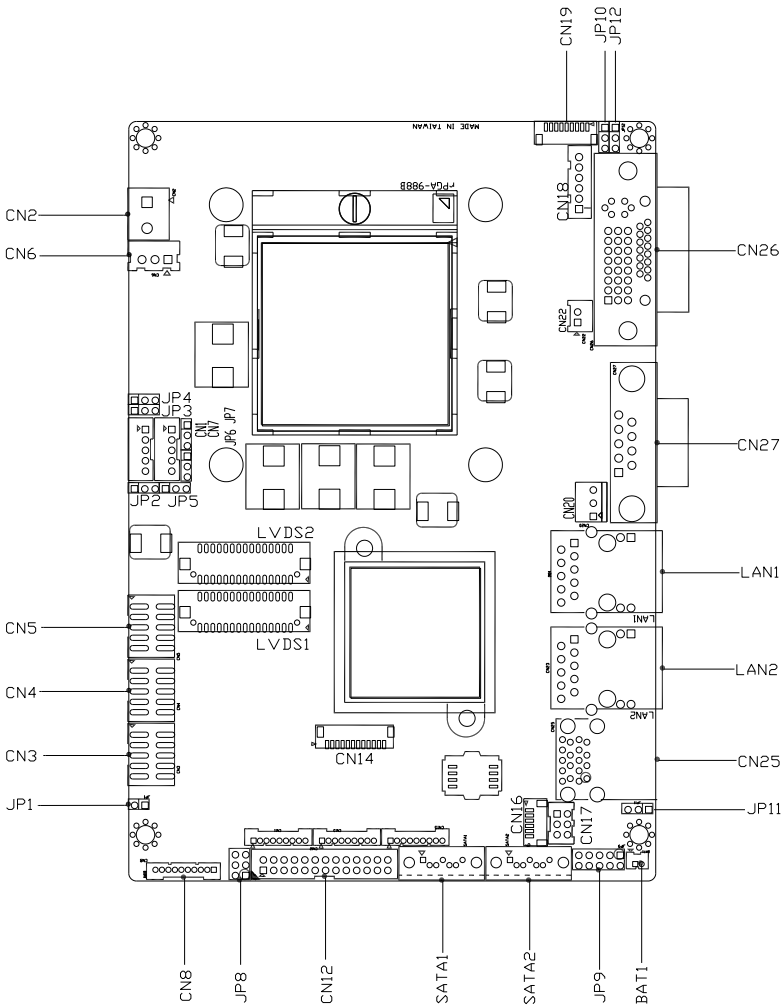



# Solder Side

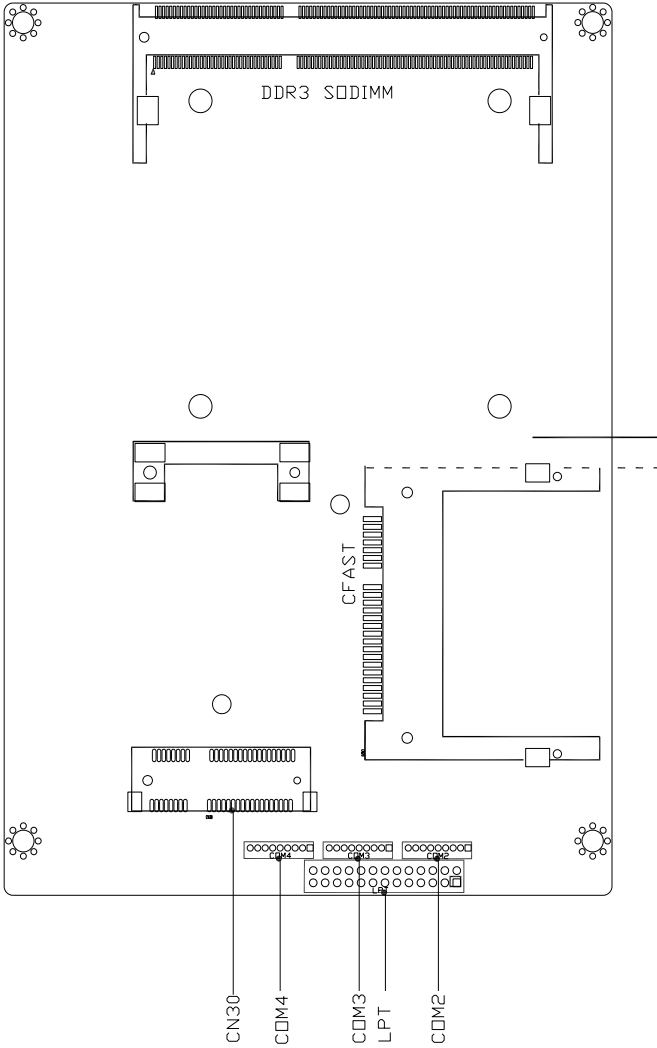

## 2.3 List of Jumpers

---

Please refer to the table below for all of the system's jumpers that you can configure for your application

Label	Function
JP3	LVDS Port 1 Backlight Inverter VCC Selection
JP5	LVDS Port 1 Operating VDD Selection
JP6	LVDS Port 1 Backlight Lightness Control Mode Selection
JP8	COM2 Pin8 Function Selection
JP9	Front Panel Connector
JP10	Touch Screen 4/5/8-wire Mode Selection
JP11	Clear CMOS Jumper
JP12	AT/ATX Power Supply Mode Selection

### 2.3.1 LVDS Port 1 Backlight Inverter VCC Selection (JP3)

---

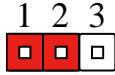

+12 V



+5 V (Default)

### 2.3.2 LVDS Port 1 Operating VDD Selection (JP5)

---

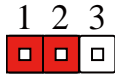

+5 V

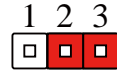

+3.3 V (Default)

### 2.3.3 LVDS Port 1 Backlight Lightness Control Mode Selection (JP6)

---

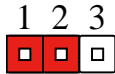

VR Mode

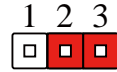

PWM Mode

### 2.3.4 COM2 Pin8 Function Selection (JP8)

---

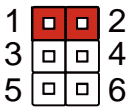

+12V

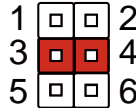

Ring (Default)

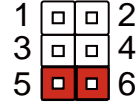

+5V

### 2.3.5 Front Panel Connector (JP9)

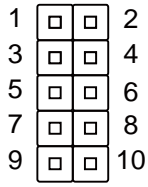

Pin	Signal
1	PWR_BTN-
2	PWR_BTN+
3	HDD_LED-
4	HDD_LED+
5	SPEAKER-
6	SPEAKER+
7	PWR_LED-
8	PWR_LED+
9	H/W RESET-

### 2.3.6 Touch Screen 4/5/8-Wire Selection (JP10)

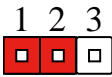

4/8-wire Mode (Default)

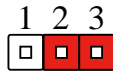

5-wire Mode

### 2.3.7 Clear CMOS (JP11)

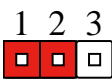

Normal (Default)

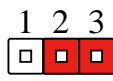

Clear CMOS

### 2.3.8 AT/ATX Power Supply Mode Selection (JP12)

---

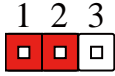

AT Mode (Default)

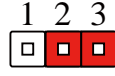

ATX Mode

## 2.4 List of Connectors

---

Please refer to the table below for all of the system's connectors that you can configure for your application

Label	Function
CN1	LVDS Port 1 Inverter / Backlight Connector
CN2	External +12V Input
CN3	USB 2.0 Ports 7 and 8
CN4	USB 2.0 Ports 5 and 6
CN5	USB 2.0 Ports 3 and 4
CN6	External +5VSB Input
CN8	Audio I/O Port
CN9	LVDS Port 1
CN11	COM Port 2
CN12	LPT / Digital I/O Port
CN13	COM Port 3
CN14	LPC Port
CN15	COM Port 4
CN16	UIM Card Module
CN17	PS/2 Keyboard/Mouse Combo Port
CN18	+5VSB Output w/SMBus
CN19	Touch Screen Connector
CN20	CPU FAN
CN22	+5V Output for SATA HDD
CN23	Realtek LAN (RJ-45) Port
CN24	Intel LAN (RJ-45) Port
CN25	USB Ports 1 and 2
CN26	VGA Port

CN27	COM Port 1 (D-SUB 9)
CN28	CFast Slot
CN29	DDR3 SODIMM Slot
CN30	Mini Card Slot
SATA1	SATA Port1 Connector
SATA2	SATA Port 2 Connector

## 2.4.1 LVDS Port 1 Inverter/ Backlight Connector (CN1)

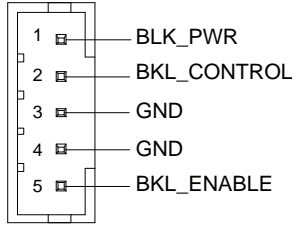

Pin	Pin Name	Signal Type	Signal level
1	BKL_PWR	PWR	+5V / +12V
2	BKL_CONTROL	OUT	
3	GND	GND	
4	GND	GND	
5	BKL_ENABLE	OUT	+5V

**Note:** LVDS1 BKL\_PWR can be set to +5V or +12V by JP3.

LVDS1 BKL\_CONTROL can be set by JP6.

## 2.4.2 External +12V Input (CN2)

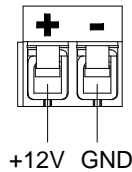

Pin	Pin Name	Signal Type	Signal level
1	+12V	PWR	+12V
2	GND	GND	



### 2.4.3 USB2.0 Port 7 and Port 8 (CN3)

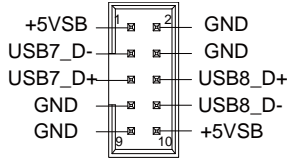

Pin	Pin Name	Signal Type	Signal level
1	+5VSB	PWR	+5V
2	GND	GND	
3	USB7_D-	DIFF	
4	GND	GND	
5	USB7_D+	DIFF	
6	USB8_D+	DIFF	
7	GND	GND	
8	USB8_D-	DIFF	
9	GND	GND	
10	+5VSB	PWR	+5V

### 2.4.4 USB2.0 Port 5 and Port 6 (CN4)

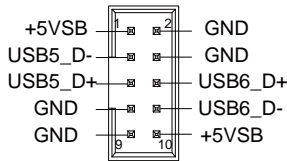

Pin	Pin Name	Signal Type	Signal level
1	+5VSB	PWR	+5V
2	GND	GND	
3	USB5_D-	DIFF	
4	GND	GND	
5	USB5_D+	DIFF	

6	USB6_D+	DIFF	
7	GND	GND	
8	USB6_D-	DIFF	
9	GND	GND	
10	+5VSB	PWR	+5V

### 2.4.5 USB2.0 Port 3 and Port 4 (CN5)

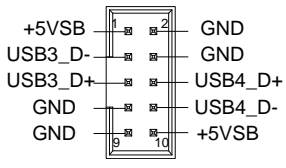

Pin	Pin Name	Signal Type	Signal level
1	+5VSB	PWR	+5V
2	GND	GND	
3	USB3_D-	DIFF	
4	GND	GND	
5	USB3_D+	DIFF	
6	USB4_D+	DIFF	
7	GND	GND	
8	USB4_D-	DIFF	
9	GND	GND	
10	+5VSB	PWR	+5V

### 2.4.6 External +5VSB Input (CN6)

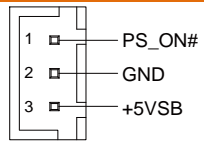

Pin	Pin Name	Signal Type	Signal level
1	PS_ON#	OUT	+3.3V
2	GND	GND	
3	+5VSB	PWR	+5V

### 2.4.7 Audio I/O Port Connector (CN8)

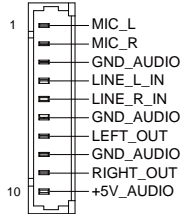

Pin	Pin Name	Signal Type	Signal level
1	MIC_L	IN	
2	MIC_R	IN	
3	GND_AUDIO	GND	
4	LINE_L_IN	IN	
5	LINE_R_IN	IN	
6	GND_AUDIO	GND	
7	LEFT_OUT	OUT	
8	GND_AUDIO	GND	
9	RIGHT_OUT	OUT	
10	+5V_AUDIO	PWR	+5V

## 2.4.8 CFast Slot (CN9)

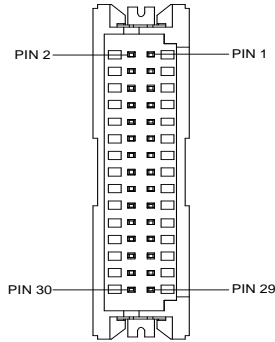

Pin	Pin Name	Signal Type	Signal level
1	BKL_ENABLE	OUT	
2	BKL_CONTROL	OUT	
3	LCD_PWR	PWR	+3.3V/+5V
4	GND	GND	
5	LVDS_A_CLK-	DIFF	
6	LVDS_A_CLK+	DIFF	
7	LCD_PWR	PWR	+3.3V/+5V
8	GND	GND	
9	LVDS_DA0-	DIFF	
10	LVDS_DA0+	DIFF	
11	LVDS_DA1-	DIFF	
12	LVDS_DA1+	DIFF	
13	LVDS_DA2-	DIFF	
14	LVDS_DA2+	DIFF	
15	LVDS_DA3-	DIFF	
16	LVDS_DA3+	DIFF	
17	DDC_DATA	I/O	+3.3V
18	DDC_CLK	I/O	+3.3V

19	LVDS_DB0-	DIFF	
20	LVDS_DB0+	DIFF	
21	LVDS_DB1-	DIFF	
22	LVDS_DB1+	DIFF	
23	LVDS_DB2-	DIFF	
24	LVDS_DB2+	DIFF	
25	LVDS_DB3-	DIFF	
26	LVDS_DB3+	DIFF	
27	LCD_PWR	PWR	+3.3V/+5V
28	GND	GND	
29	LVDS_B_CLK-	DIFF	
30	LVDS_B_CLK+	DIFF	

**Note:** LVDS1 LCD\_PWR can be set to +3.3V or +5V by JP5.

## 2.4.9 COM Port 2 Connector (CN11)

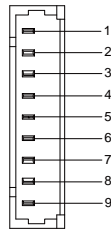

### RS-232

Pin	Pin Name	Signal Type	Signal level
1	DCD	IN	
2	DSR	IN	
3	RX	IN	
4	RTS	OUT	±9V
5	TX	OUT	±9V

6	CTS	IN	
7	DTR	OUT	±9V
8	RI/+5V/+12V	IN/ PWR	+5V/+12V
9	GND	GND	

## RS-422

Pin	Pin Name	Signal Type	Signal level
1	RS422_TX-	OUT	±5V
2	NC		
3	RS422_RX+	IN	
4	NC		
5	RS422_TX+	OUT	±5V
6	NC		
7	RS422_RX-	IN	
8	NC/+5V/+12V	PWR	+5V/+12V
9	GND	GND	

## RS-485

Pin	Pin Name	Signal Type	Signal level
1	RS485_D-	I/O	±5V
2	NC		
3	NC		
4	NC		
5	RS485_D+	I/O	±5V
6	NC		
7	NC		
8	NC/+5V/+12V	PWR	+5V/+12V
9	GND	GND	

**Note:** COM2 RS-232/422/485 can be set by BIOS setting. Default is RS-232. Pin 8 function can be set by JP8.

## 2.4.10 LPT/ Digital I/O Port Connector (CN12)

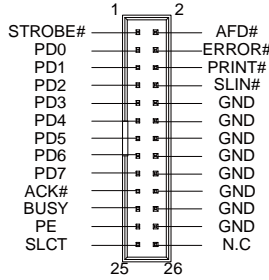

LPT Mode			
Pin	Pin Name	Signal Type	Signal level
1	STROBE#	IN	
2	AFD#	I/O	
3	PD0	I/O	
4	ERROR#	IN	
5	PD1	I/O	
6	PRINT#	I/O	
7	PD2	I/O	
8	SLIN#	I/O	
9	PD3	I/O	
10	GND	GND	
11	PD4	I/O	
12	GND	GND	
13	PD5	I/O	
14	GND	GND	
15	PD6	I/O	

16	GND	GND
17	PD7	I/O
18	GND	GND
19	ACK#	IN
20	GND	GND
21	BUSY	IN
22	GND	GND
23	PE	IN
24	GND	GND
25	SLCT	IN
26	NC	

**Note:** LPT / Digital IO can be set by BIOS setting. Default is LPT Function

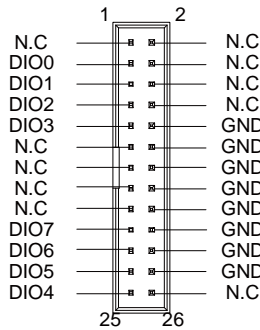

#### DIO Mode

Pin	Pin Name	Signal Type	Signal level
1	NC		
2	NC		
3	DIO0	I/O	+5V
4	NC		
5	DIO1	I/O	+5V
6	NC		
7	DIO2	I/O	+5V



8	NC		
9	DIO3	I/O	+5V
10	GND	GND	
11	NC		
12	GND	GND	
13	NC		
14	GND	GND	
15	NC		
16	GND	GND	
17	NC		
18	GND	GND	
19	DIO7	I/O	+5V
20	GND	GND	
21	DIO6	I/O	+5V
22	GND	GND	
23	DIO5	I/O	+5V
24	GND	GND	
25	DIO4	I/O	+5V
26	NC		

GPIO Port # /Pin Name	Location (Pin #)	I/O Port Access Address
Port 1/DIO0	3	Bit 0 of 0xA06
Port 2/DIO1	5	Bit 1 of 0xA06
Port 3/DIO2	7	Bit 2 of 0xA06
Port 4/DIO3	9	Bit 3 of 0xA06
Port 5/DIO4	25	Bit 0 of 0xA07
Port 6/DIO5	23	Bit 1 of 0xA07
Port 7/DIO6	21	Bit 2 of 0xA07
Port 8/DIO7	19	Bit 3 of 0xA07

## 2.4.11 COM Port 3 Connector (CN13)

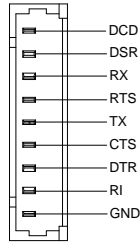

Pin	Pin Name	Signal Type	Signal level
1	DCD	IN	
2	DSR	IN	
3	RX	IN	
4	RTS	OUT	±9V
5	TX	OUT	±9V
6	CTS	IN	
7	DTR	OUT	±9V
8	RI	IN	
9	GND	GND	

## 2.4.12 LPC Port Connector (CN14)

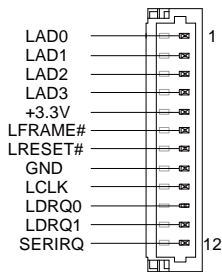

Pin	Pin Name	Signal Type	Signal level
1	LAD0	I/O	+3.3V

2	LAD1	I/O	+3.3V
3	LAD2	I/O	+3.3V
4	LAD3	I/O	+3.3V
5	+3.3V	PWR	+3.3V
6	LFRAME#	IN	
7	LRESET#	OUT	+3.3V
8	GND	GND	
9	LCLK	OUT	
10	LDRQ0	IN	
11	LDRQ1	IN	
12	SERIRQ	I/O	+3.3V

### 2.4.13 COM Port 4 Connector (CN15)

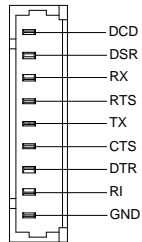

Pin	Pin Name	Signal Type	Signal level
1	DCD	IN	
2	DSR	IN	
3	RX	IN	
4	RTS	OUT	±9V
5	TX	OUT	±9V
6	CTS	IN	
7	DTR	OUT	±9V
8	RI	IN	

### 2.4.14 UIM Card Module (CN16)

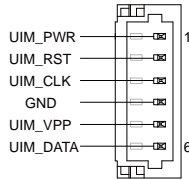

Pin	Pin Name	Signal Type	Signal level
1	UIM_PWR	PWR	
2	UIM_RST	IN	
3	UIM_CLK	IN	
4	GND	GND	
5	UIM_VPP	PWR	
6	UIM_DATA	I/O	

### 2.4.15 PS/2 Keyboard/Mouse Combo Port Connector (CN17)

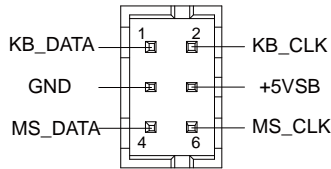

Pin	Pin Name	Signal Type	Signal level
1	KB_DATA	I/O	+5V
2	KB_CLK	I/O	+5V
3	GND	GND	
4	+5VSB	PWR	+5V
5	MS_DATA	I/O	+5V
6	MS_CLK	I/O	+5V

## 2.4.16 +5VSB Output w/SMBus (CN18)

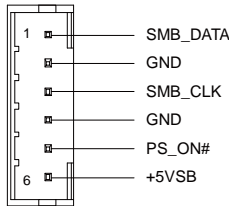

Pin	Pin Name	Signal Type	Signal level
1	SMB_DATA	I/O	+3.3V
2	GND	GND	
3	SMB_CLK	I/O	+3.3V
4	GND	GND	
5	PS_ON#	OUT	+3.3V
6	+5VSB	PWR	+5V

## 2.4.17 Touch Screen Connector (CN19)

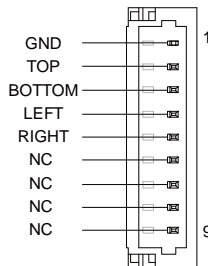

4-wire

Pin	Pin Name	Signal Type	Signal level
1	GND	GND	
2	TOP	IN	
3	BOTTOM	IN	
4	LEFT	IN	

## 4-wire

Pin	Pin Name	Signal Type	Signal level
5	RIGHT	IN	
6	NC		
7	NC		
8	NC		
9	NC		

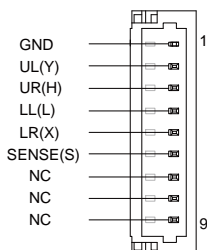

## 5-wire

Pin	Pin Name	Signal Type	Signal level
1	GND	GND	
2	UL(Y)	IN	
3	UR(H)	IN	
4	LL(L)	IN	
5	LR(X)	IN	
6	SENSE(S)	IN	
7	NC		
8	NC		
9	NC		

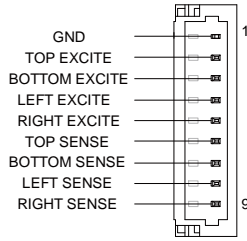

8-wire			
Pin	Pin Name	Signal Type	Signal level
1	GND	GND	
2	TOP EXCITE	IN	
3	BOTTOM EXCITE	IN	
4	LEFT EXCITE	IN	
5	RIGHT EXCITE	IN	
6	TOP SENSE	IN	
7	BOTTOM SENSE	IN	
8	LEFT SENSE	IN	
9	RIGHT SENSE	IN	

**Note:** Touch mode can be set by JP10

### 2.4.18 CPU FAN Connector (CN20)

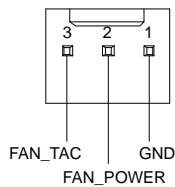

Pin	Pin Name	Signal Type	Signal level
1	GND	GND	
2	FAN_POWER	PWR	+5V

### 2.4.19 +5V Output for SATA HDD (CN22)

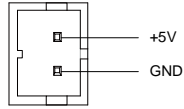

Pin	Pin Name	Signal Type	Signal level
1	+5V	PWR	+5V
2	GND	GND	

### 2.4.20 Realtek LAN (RJ-45) Port (CN23)

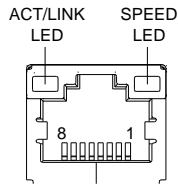

Pin	Pin Name	Signal Type	Signal level
1	MDI0+	DIFF	
2	MDI0-	DIFF	
3	MDI1+	DIFF	
4	MDI2+	DIFF	
5	MDI2-	DIFF	
6	MDI1-	DIFF	
7	MDI3+	DIFF	
8	MDI3-	DIFF	



## 2.4.21 Intel LAN (RJ-45) Port (CN24)

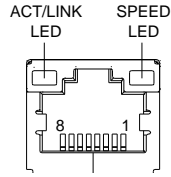

Pin	Pin Name	Signal Type	Signal level
1	MDI0+	DIFF	
2	MDI0-	DIFF	
3	MDI1+	DIFF	
4	MDI2+	DIFF	
5	MDI2-	DIFF	
6	MDI1-	DIFF	
7	MDI3+	DIFF	
8	MDI3-	DIFF	

## 2.4.22 USB Port 1 and Port 2 (CN25)

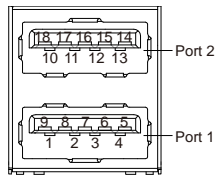

Pin	Pin Name	Signal Type	Signal level
1	+5VSB	PWR	+5V
2	USB1_D-	DIFF	
3	USB1_D+	DIFF	
4	GND	GND	
5	USB1_SSRX-	DIFF	
6	USB1_SSRX+	DIFF	
7	GND	GND	

8	USB1_SSTX-	DIFF	
9	USB1_SSTX+	DIFF	
10	+5VSB	PWR	+5V
11	USB2_D-	DIFF	
12	USB2_D+	DIFF	
13	GND	GND	
14	USB2_SSRX-	DIFF	
15	USB2_SSRX+	DIFF	
16	GND	GND	
17	USB2_SSTX-	DIFF	
18	USB2_SSTX+	DIFF	

### 2.4.23 VGA Port (CN26)

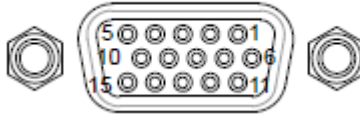

Pin	Pin Name	Signal Type	Signal level
1	RED	OUT	
2	GREEN	OUT	
3	BLUE	OUT	
4	NC		
5	GND	GND	
6	RED_GND_RTN	GND	
7	GREEN_GND_RTN	GND	
8	BLUE_GND_RTN	GND	
9	+5V	PWR	+5V
10	GND	GND	
11	NC		

12	DDC_DATA	I/O	+5V
13	HSYNC	OUT	
14	VSYNC	OUT	
15	DDC_CLK	I/O	+5V

#### 2.4.24 COM Port 1 (D-SUB 9) (CN27)

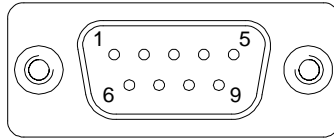

Pin	Pin Name	Signal Type	Signal level
1	DCD	IN	
2	RX	IN	
3	TX	OUT	±9V
4	DTR	OUT	±9V
5	GND	GND	
6	DSR	IN	
7	RTS	OUT	±9V
8	CTS	IN	
9	RI	IN	

#### 2.4.25 CFast Slot (CN28)

Pin	Pin Name	Signal Type	Signal level
S1	GND	GND	
S2	SATA_TX+	DIFF	
S3	SATA_TX-	DIFF	
S4	GND	GND	
S5	SATA_RX-	DIFF	

S6	SATA_RX+	DIFF	
S7	GND	GND	
PC1	NC		
PC2	GND	GND	
PC3	NC		
PC4	NC		
PC5	NC		
PC6	NC		
PC7	GND	GND	
PC8	NC		
PC9	NC		
PC10	NC		
PC11	NC		
PC12	NC		
PC13	+3.3V	PWR	+3.3V
PC14	+3.3V	PWR	+3.3V
PC15	GND	GND	
PC16	GND	GND	
PC17	NC		

#### 2.4.26 DDR3 SODIMM Slot (CN29)

Standard specification

#### 2.4.27 Mini Card Slot (CN30)

Pin	Pin Name	Signal Type	Signal level
1	PCIE_WAKE#	IN	
2	+3.3VSB	PWR	+3.3V

3	NC		
4	GND	GND	
5	NC		
6	+1.5V	PWR	+1.5V
7	PCIE_CLK_REQ#	IN	
8	UIM_PWR	PWR	
9	GND	GND	
10	UIM_DATA	I/O	
11	PCIE_REF_CLK-	DIFF	
12	UIM_CLK	IN	
13	PCIE_REF_CLK+	DIFF	
14	UIM_RST	IN	
15	GND	GND	
16	UIM_VPP	PWR	
17	NC		
18	GND	GND	
19	NC		
20	W_DISABLE#	OUT	+3.3V
21	GND	GND	
22	PCIE_RST#	OUT	+3.3V
23	PCIE_RX-	DIFF	
24	+3.3VSB	PWR	+3.3V
25	PCIE_RX+	DIFF	
26	GND	GND	
27	GND	GND	
28	+1.5V	PWR	+1.5V
29	GND	GND	
30	SMB_CLK	I/O	+3.3V
31	PCIE_TX-	DIFF	

32	SMB_DATA	I/O	+3.3V
33	PCIE_TX+	DIFF	
34	GND	GND	
35	GND	GND	
36	USB_D-	DIFF	
37	GND	GND	
38	USB_D+	DIFF	
39	+3.3VSB	PWR	+3.3V
40	GND	GND	
41	+3.3VSB	PWR	+3.3V
42	NC		
43	GND	GND	
44	NC		
45	NC		
46	NC		
47	NC		
48	+1.5V	PWR	+1.5V
49	NC		
50	GND	GND	
51	NC		
52	+3.3VSB	PWR	+3.3V

### 2.4.28 SATA Port 1 (SATA1)

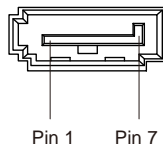

Pin	Pin Name	Signal Type	Signal level
-----	----------	-------------	--------------

1	GND	GND
2	SATA_TX+	DIFF
3	SATA_TX-	DIFF
4	GND	GND
5	SATA_RX-	DIFF
6	SATA_RX+	DIFF
7	GND	GND

### 2.4.29 SATA Port 2 (SATA2)

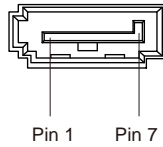

Pin	Pin Name	Signal Type	Signal Level
1	GND	GND	
2	SATA_TX+	DIFF	
3	SATA_TX-	DIFF	
4	GND	GND	
5	SATA_RX-	DIFF	
6	SATA_RX+	DIFF	
7	GND	GND	

## 2.5 CFast™ Card Installation

Step 1: Remove the screws on the AEC-6637

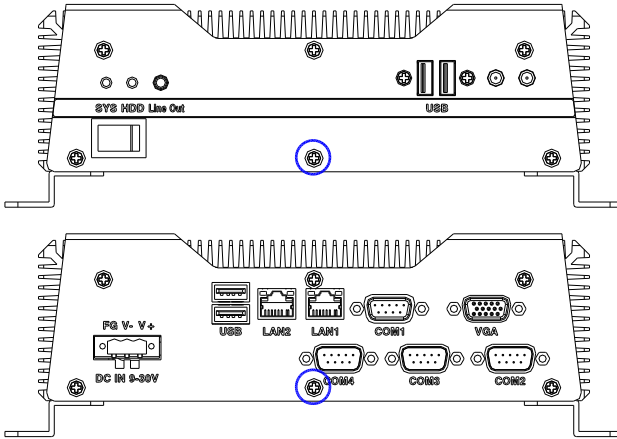

Step 2: Remove the screws on the brackets

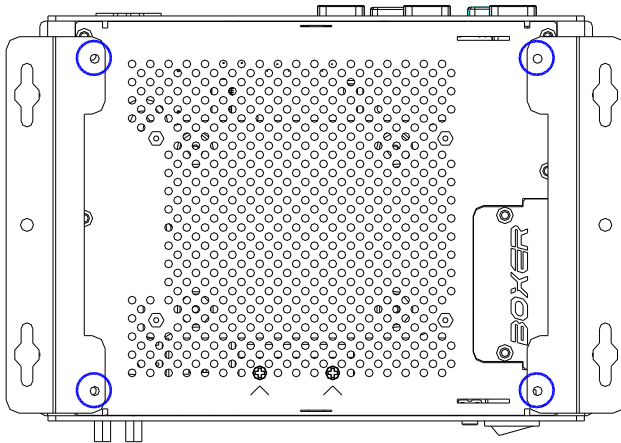



Step 3: Remove the screws on the bottom cover

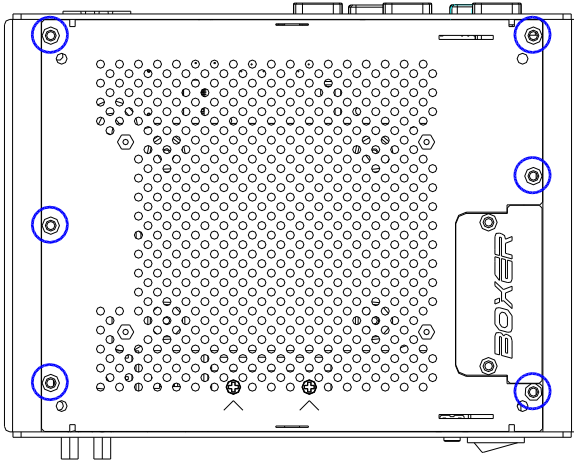

Step 4: Remove the screws on the CFast™ bracket

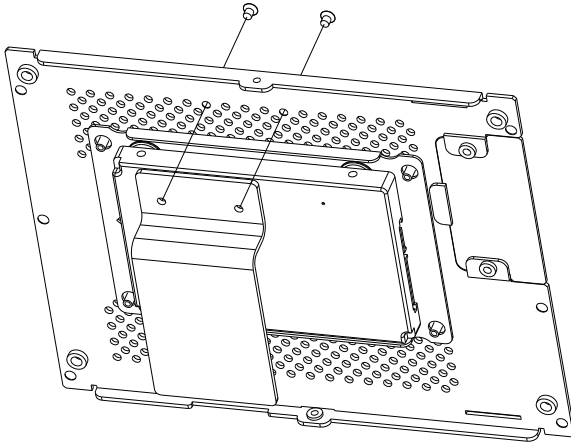

Step 5: Install the CFast™ Card to the CFast™ slot and adhere the thermal pad onto the CFast™ Card. Then cover up the CFast™ Bracket

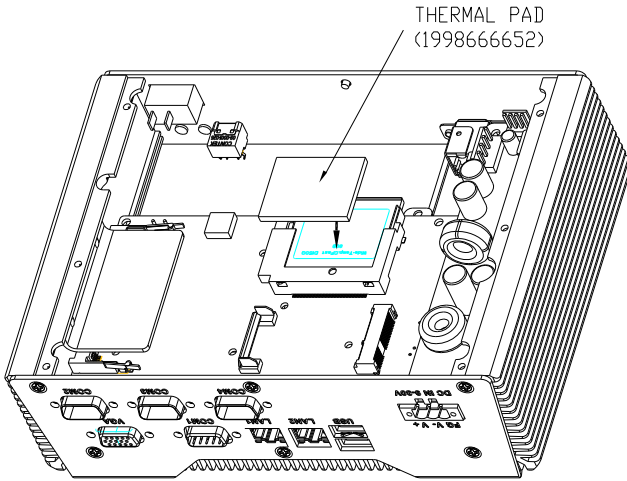

Step 6: Tighten the screws on the CFast™ bracket to complete the installation

## 2.6 Hard Disk Drive (HDD) Installation

Step 1: Remove the screws on the AEC-6637

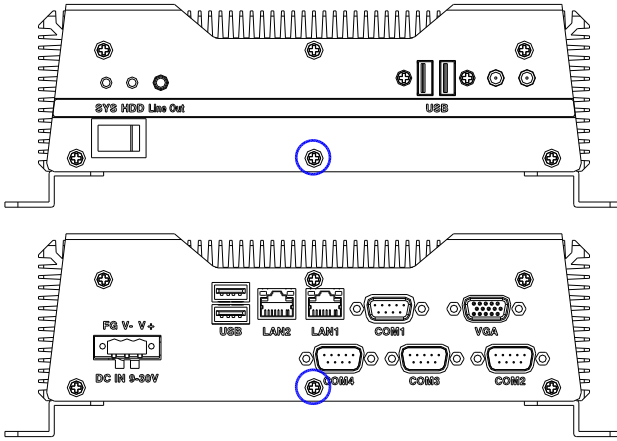

Step 2: Remove the screws on the brackets

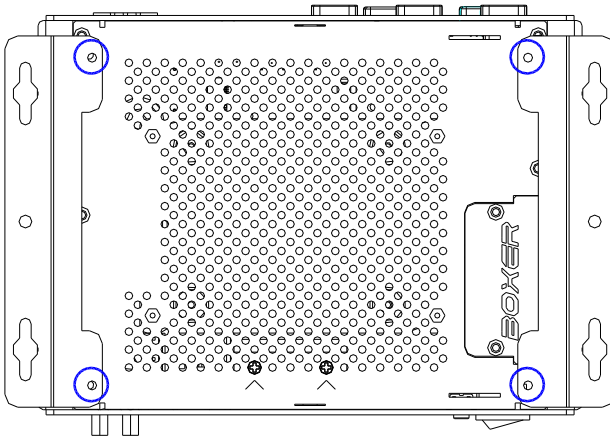

Step 3: Remove on the screws on the bottom cover

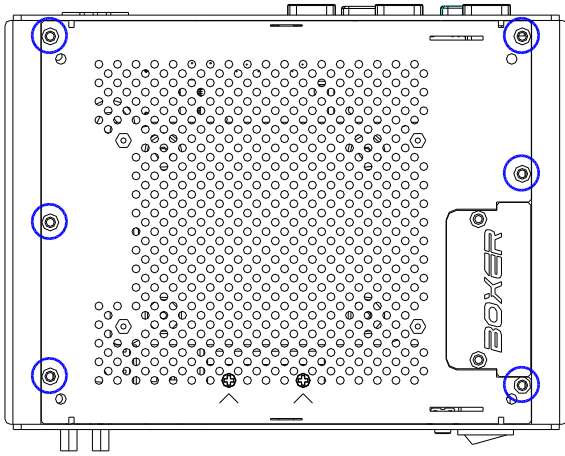

Step 4: Get the HDD and HDD Bracket ready. Attach the HDD to the HDD bracket and tighten the screws

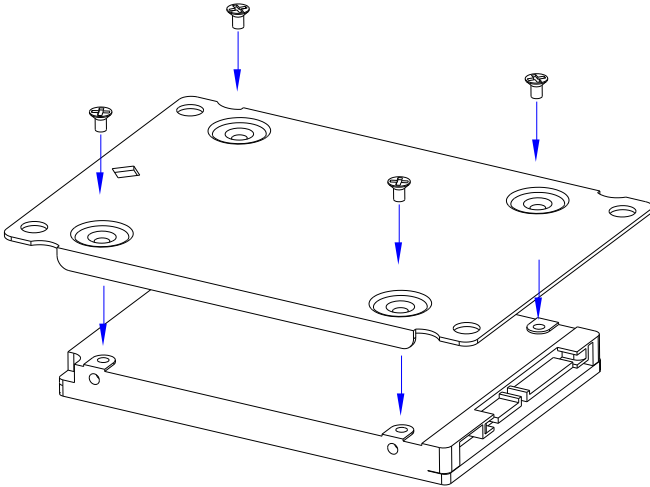

Step 5: Connect the SATA cable to the HDD

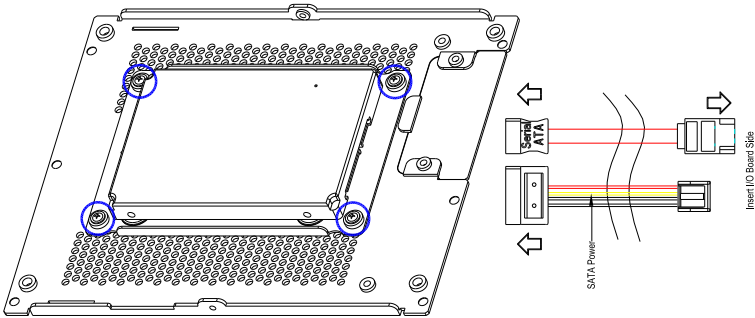

Step 6: Close the bottom cover of the AEC-6637. Tight the screws to secure.

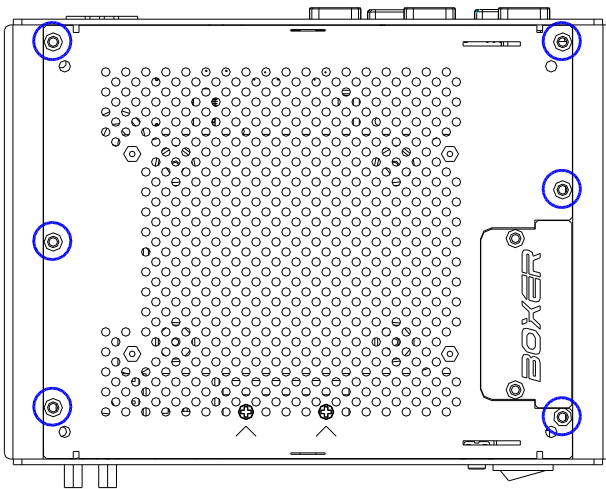

## 2.7 Memory Card Installation

Step 1: Remove the screws on the AEC-6637

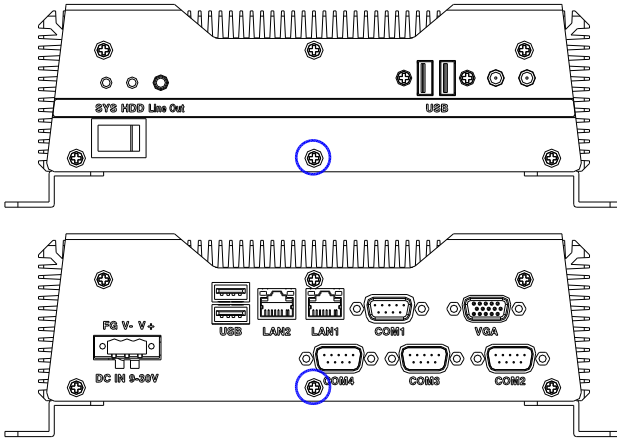

Step 2: Remove the screws on the brackets

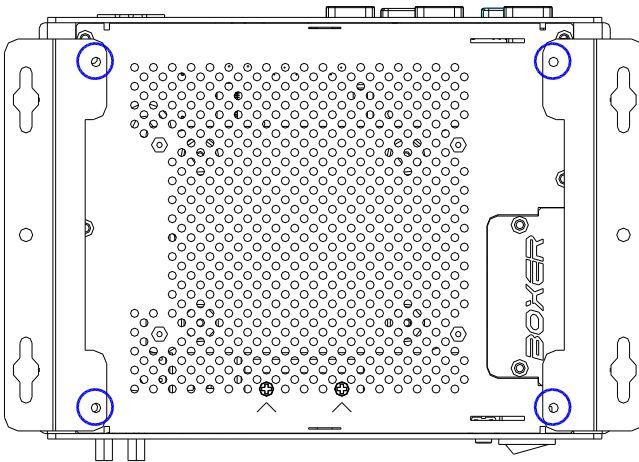

Step 3: Remove the screws on the bottom cover

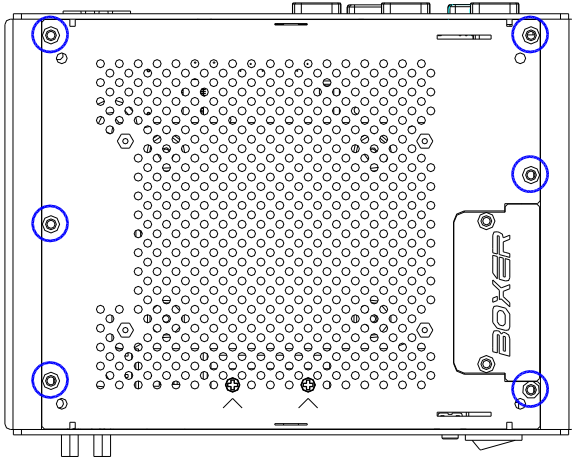

Step 4: Remove the screws on the bracket of Memory Card

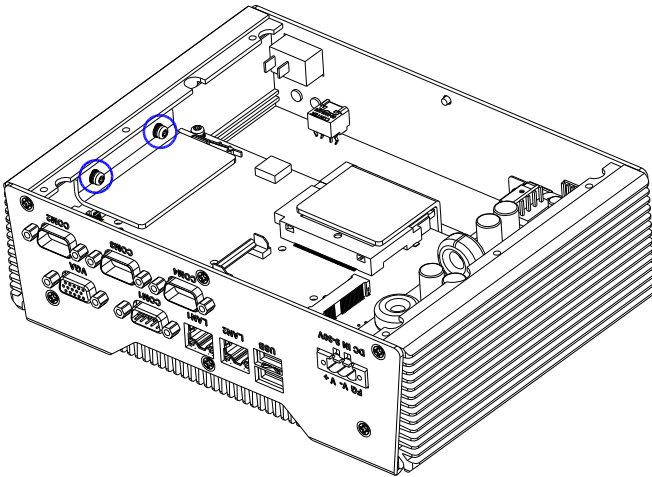

Step 5: Adhere the Thermal pads onto the top and bottom of the Memory Card, and then insert the RAM diagonally to the memory slot, push down to secure.

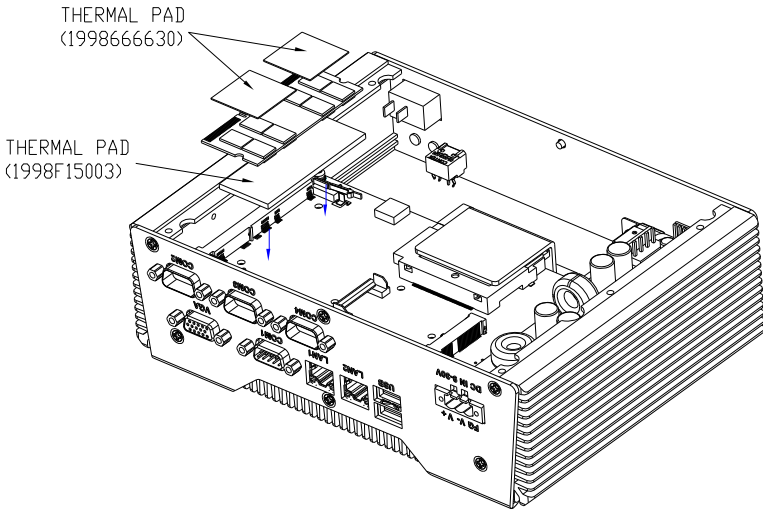

Step 6: Tighten the screws of the bracket of Memory Card to finish the installation

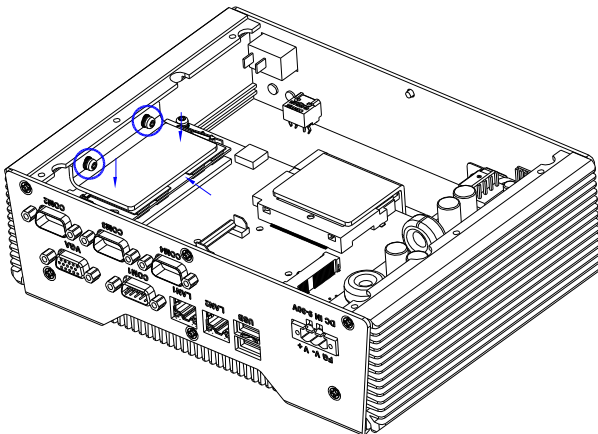



## 2.8 Wallmount Kit Installation

To attach the wallmount kit on to the AEC-6637, tightens four screws as shown in the diagram below.

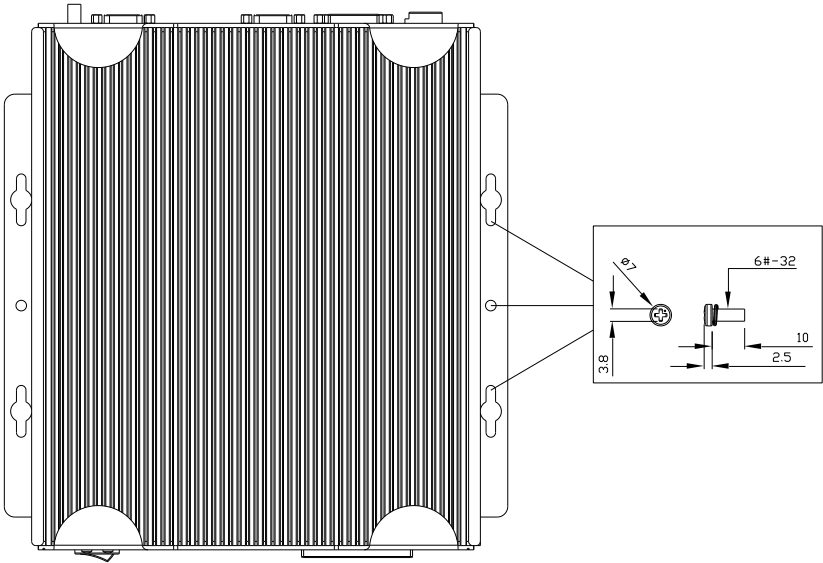

# Chapter 3

---

AMI BIOS Setup

## 3.1 System Test and Initialization

---

The system uses certain routines to perform testing and initialization. If an error, fatal or non-fatal, is encountered, a few short beeps or an error message will be outputted. The board can usually continue the boot up sequence with non-fatal errors.

The system configuration verification routines check the current system configuration against the values stored in the CMOS memory. If they do not match, an error message will be outputted, in which case you will need to run the BIOS setup program to set the configuration information in memory.

There are three situations in which you will need to change the CMOS settings:

- You are starting your system for the first time
- You have changed your system's hardware
- The CMOS memory has lost power and the configuration information is erased

The system's CMOS memory uses a backup battery for data retention, which is to be replaced once emptied.

## 3.2 AMI BIOS Setup

---

The AMI BIOS ROM has a pre-installed Setup program that allows users to modify basic system configurations, which is stored in the battery-backed CMOS RAM and BIOS NVRAM so that the information is retained when the power is turned off.

To enter BIOS Setup, press <Del> or <F2> immediately while your computer is powering up.

The function for each interface can be found below.

**Main** – Date and time can be set here. Press <Tab> to switch between date elements

**Advanced** – Enable/ Disable boot option for legacy network devices

**Chipset** – For hosting bridge parameters

**Boot** – Enable/ Disable quiet Boot Option

**Security** – The setup administrator password can be set here

**Save & Exit** – Save your changes and exit the program

### 3.3 Setup Submenu: Main

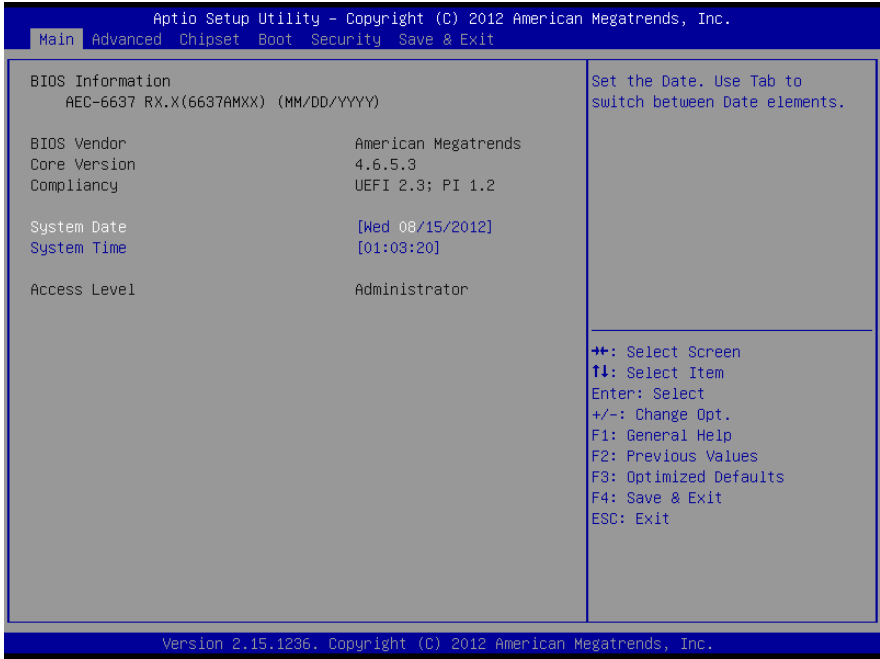

Options summary: **(default setting)**

System Date	Day MM:DD:YYYY	
Change the month, year and century. The 'Day' is changed automatically.		
System Time	HH : MM : SS	
Change the clock of the system.		

### 3.4 Setup Submenu: Advanced

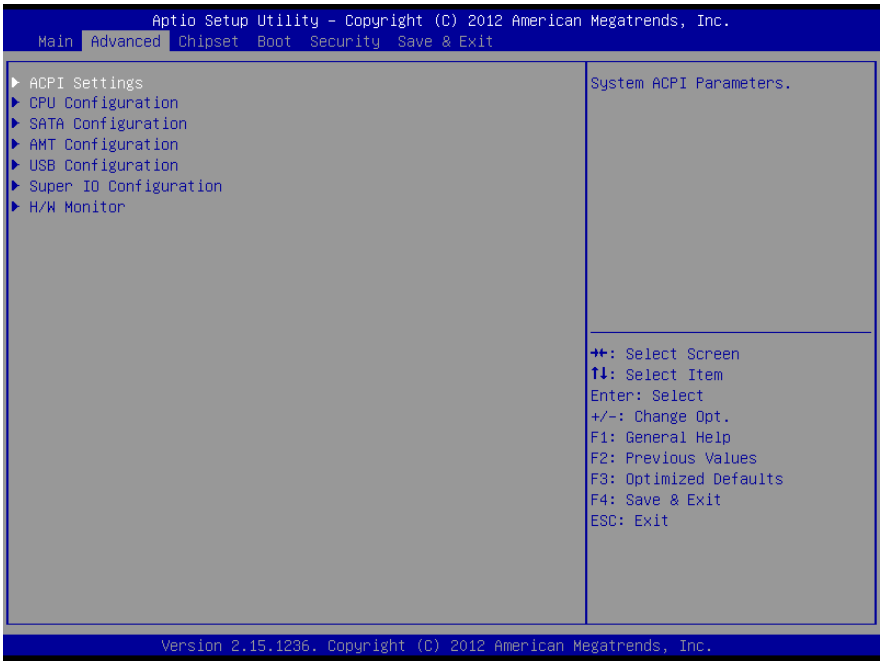

Options summary: **(default setting)**

ACPI Settings		
System ACPI Parameters		
CPU Configuration		
CPU Configuration Parameters		
SATA Configuration		
SATA Device Options Settings		
AMT Configuration		
AMT Configuration Parameters		
USB Configuration		
USB Configuration Parameters		

H/W Monitor		
Monitor hardware status		
Super IO Configuration		
Super IO Configuration Parameters		

### 3.4.1 Advanced: ACPI Settings

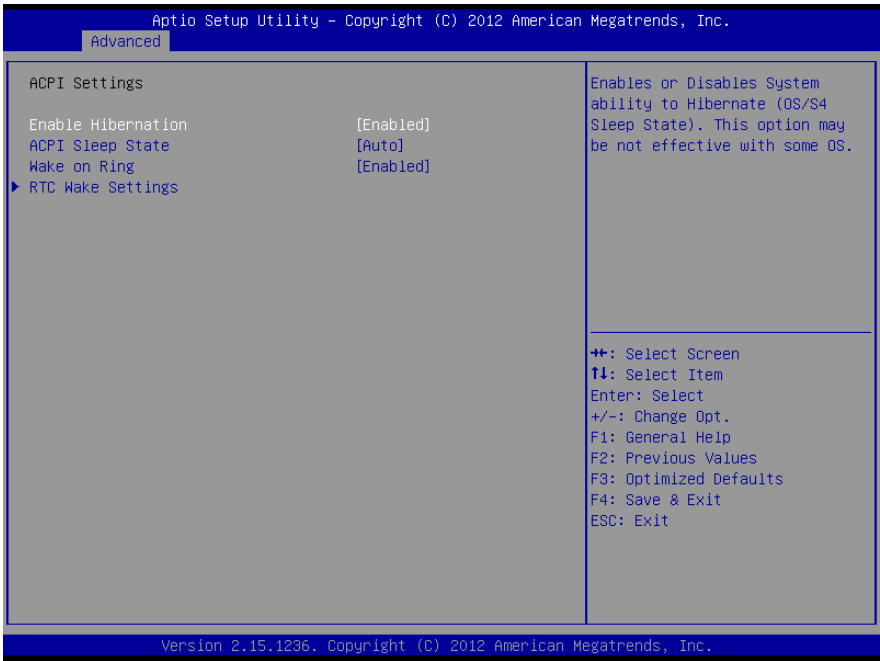

Options summary: (default setting)

Enable Hibernation	Enabled	
	Disabled	
Enabled or disabled hibernate (OS/S4 Sleep State).		
ACPI Sleep State	Suspend Disabled	
	S1 only(CPU Stop Clock)	
	<b>S3 only(Suspend to RAM)</b>	
	Auto	
Select the ACPI state used for System Suspend		
Wake on Ring	Enabled	
	Disabled	



Enabled or disabled wake on ring function.		
RTC Wake Settings		
Enable system to wake from S5 using RTC alarm.		

### 3.4.1.1 ACPI Settings: RTC Wake Settings

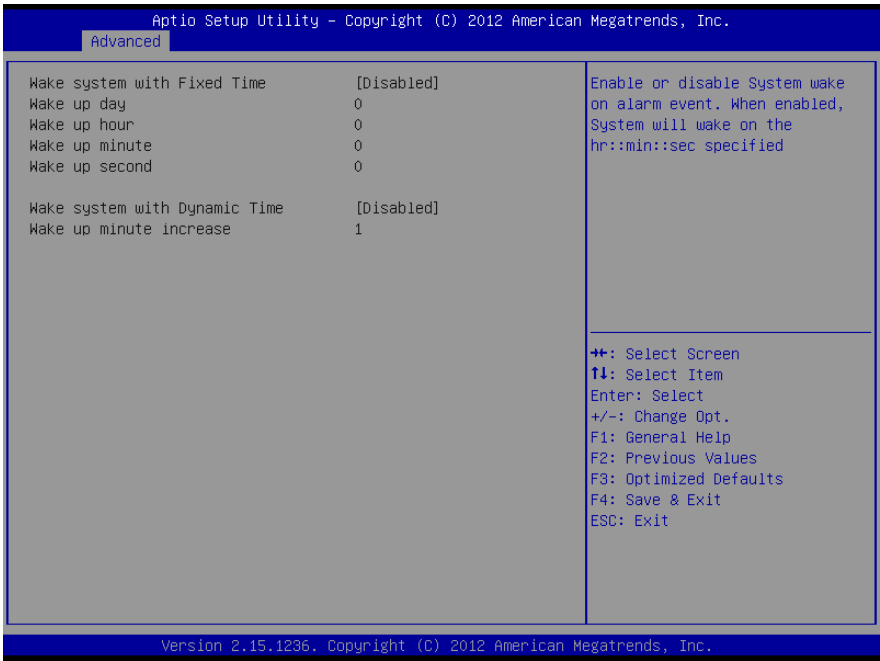

Options summary: (default setting)

Wake system with Fixed Time	Disabled	
	Enabled	
Enable or disable System wake on alarm event. Wake up time is setting by following settings.		
Wake up day	0-31	
Wake up hour	0-23	
Wake up minute	0-59	

Wake up second	0-59	
Wake system with Dynamic Time	<b>Disabled</b>	
	Enabled	
Enable or disable System wake on alarm event. Wake up time is current time + Increase minutes.		
Wake up minute increase	1-5	

### 3.4.2 Advanced: CPU Configuration

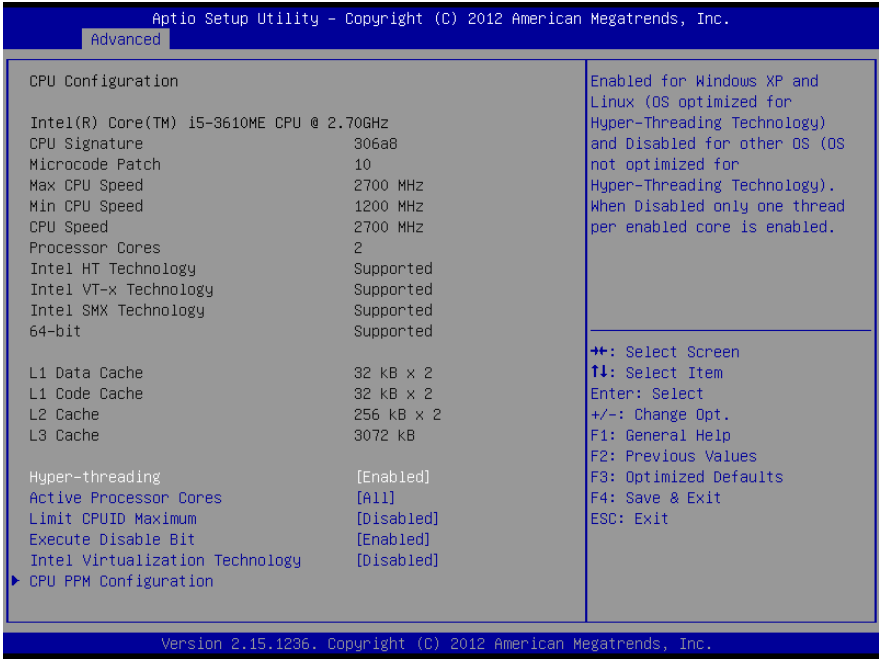

Options summary: (default setting)

Hyper-Threading	Disabled	
	Enabled	
En/Disable CPU Hyper-Threading function		
Active Processor Cores	ALL	
	1 to Max CPU cores	
Number of CPU cores to be active.		
Limit CPUID Maximum	Disabled	
	Enabled	
Disabled for Windows XP		
Execute Disable Bit	Disabled	

	<b>Enabled</b>	
En/Disable XD bit for supporting OS		
Intel Virtualization Technology	<b>Disabled</b>	
	Enabled	
En/Disable Intel VT-x function		
CPU PPM Configuration		
CPU Power Management configuration		

### 3.4.2.1 CPU Configuration: CPU PPM Configuration

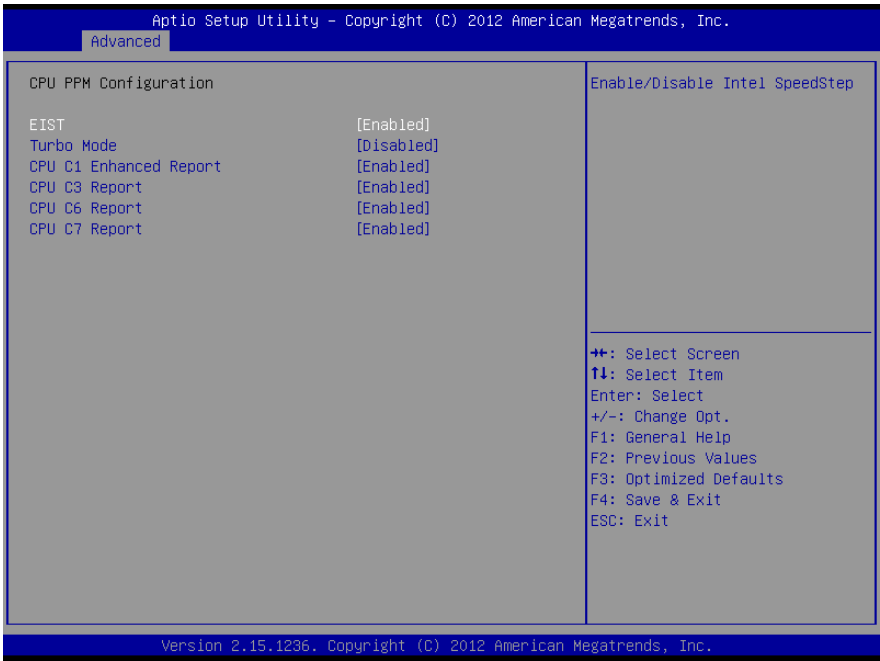

Options summary: (default setting)

EIST	Enabled	
	Disabled	
En/Disable Intel SpeedStep		
Turbo Mode	Disabled	
	Enabled	
En/Disable Intel Turbo Mode		
CPU C1 Enhanced Report	Disabled	
	Enabled	
Report CPU support ACPI C1 Enhanced state to OS		
CPU C3 Report	Disabled	

	<b>Enabled</b>	
Report CPU support ACPI C3 state to OS		
CPU C6 Report	Disabled	
	<b>Enabled</b>	
Report CPU support ACPI C6 state to OS		
CPU C7 Report	Disabled	
	<b>Enabled</b>	
Report CPU support ACPI C7 state to OS		

### 3.4.3 Advanced: SATA Configuration

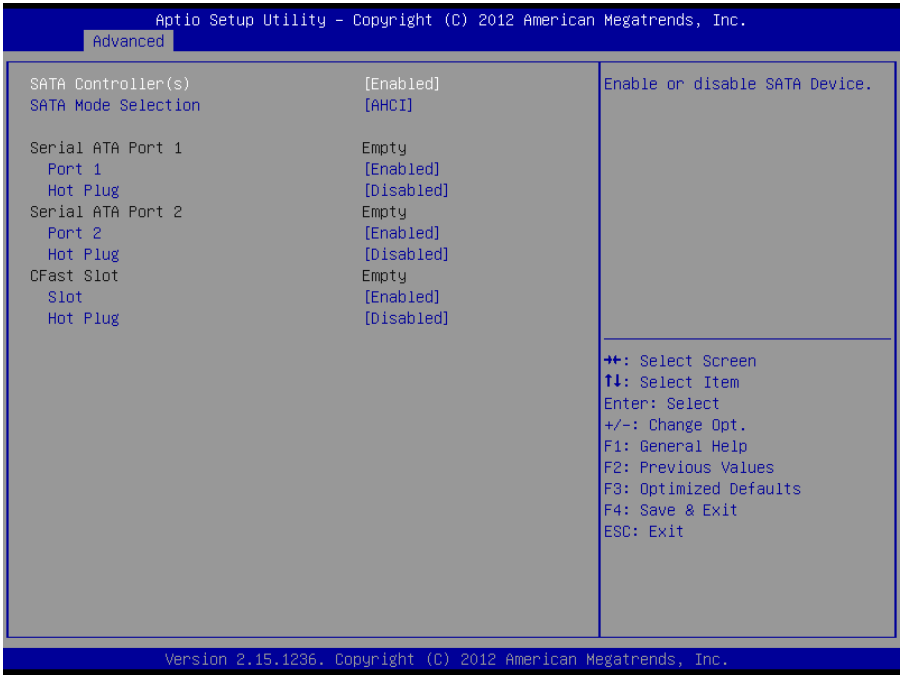

Options summary: (default setting)

SATA Controller(s)	Disabled	
	Enabled	
En/Disable SATA controller		
Configure SATA as	IDE	Available for QM77 Sku
	AHCI	
	RAID	
Configure SATA controller operating as IDE/AHCI/RAID mode.		
Port 1/Port 2/CFAST Slot	Disabled	
	Enabled	
En/Disable the selected port.		



Hot Plug	Disabled	
	Enabled	
En/Disable Hot Plug feature for specified port.		

### 3.4.4 Advanced: AMT Configuration

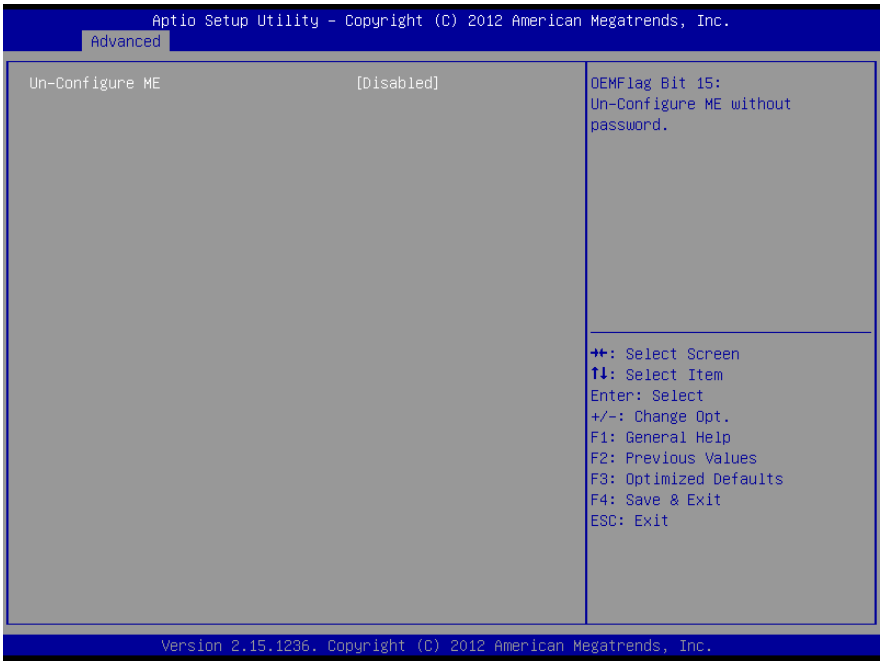

Options summary: (default setting)

Un-Configure ME	Enabled	
	Disabled	
OEMFlag Bit 15: Un-Configure ME without password		

### 3.4.5 Advanced: USB Configuration

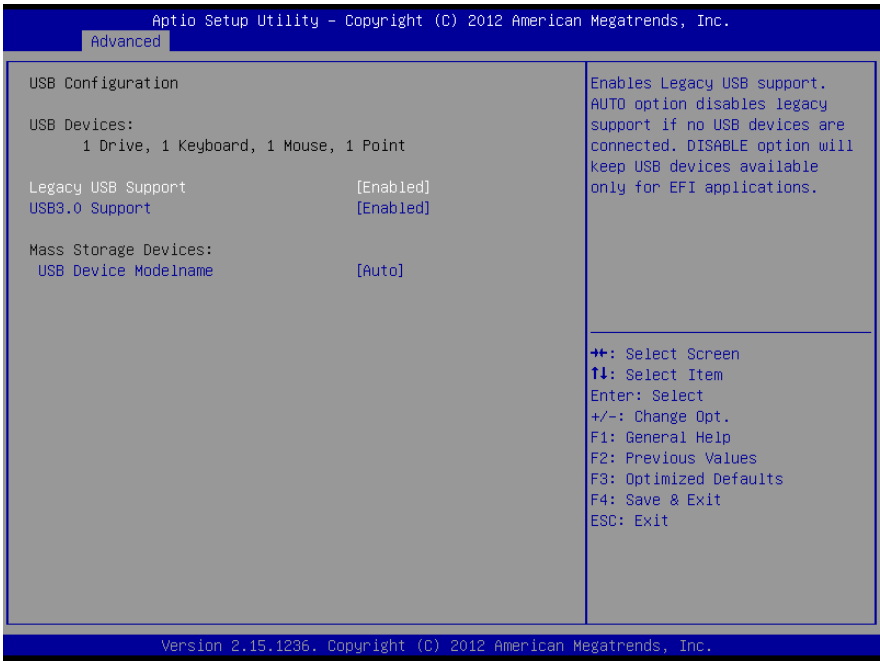

Options summary: (default setting)

Legacy USB Support	<b>Enabled</b>	
	Disabled	
	Auto	
Enables BIOS Support for Legacy USB Support. When enabled, USB can be functional in legacy environment like DOS. AUTO option disables legacy support if no USB devices are connected. DISABLE option will keep USB devices available only for EFI application		
USB3.0 Support	<b>Enabled</b>	
	Disabled	
Enables BIOS Support for USB3.0 (XHCI). When disabled, PCH USB3.0 controller will also be disabled.		

Device Name (Emulation Type)	Auto	
	Floppy	
	Forced FDD	
	Hard Disk	
	CD-ROM	

If Auto. USB devices less than 530MB will be emulated as Floppy and remaining as Floppy and remaining as hard drive. Forced FDD option can be used to force a HDD formatted drive to boot as FDD(Ex. ZIP drive)

### 3.4.6 Advanced: H/W Monitor

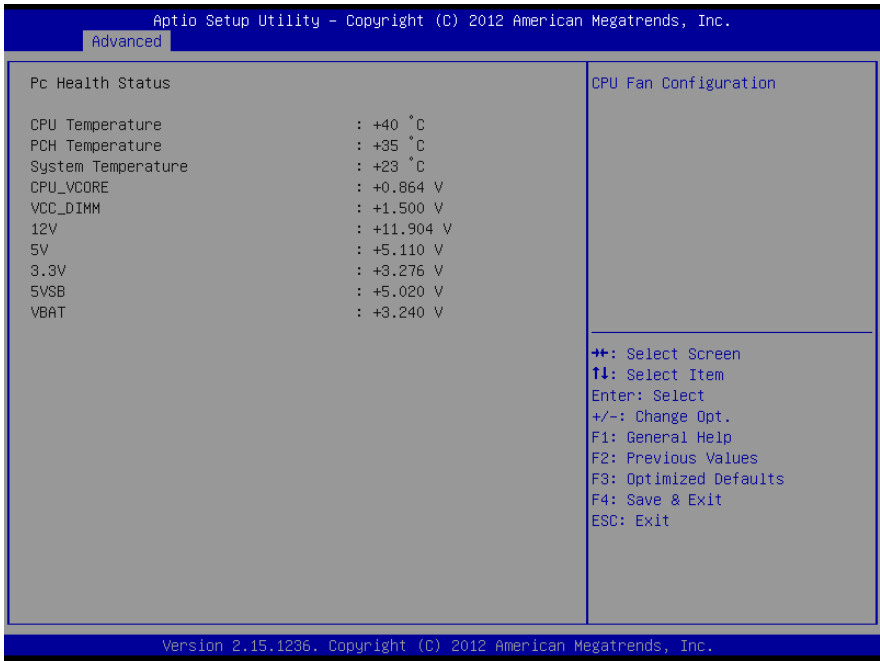

### 3.4.7 Advanced: Super IO Configuration

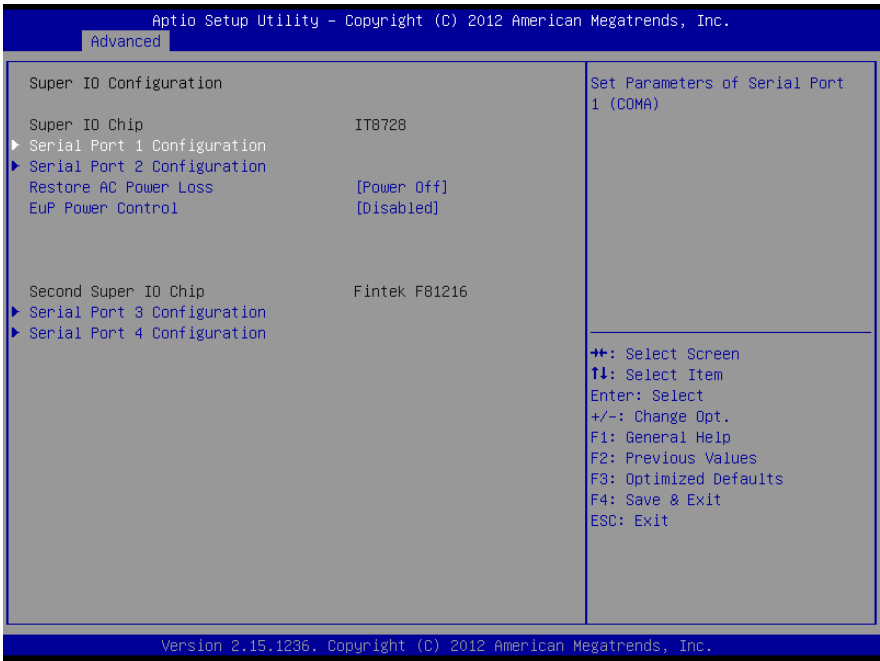

Options summary: (default setting)

Serial Port 1/2/3/4 Configuration		
Set Parameters of Serial Port 1/2/3/4		
Restore AC Power Loss	Power Off	
	Power On	
	Last State	
Select AC power state when power is re-applied after a power failure.		
EuP Power Control	Disabled	
	Enabled	
Configure Energy-using Product(EuP) Power Control.		

### 3.4.7.1 Super IO Configuration: Serial Port 1 Configuration

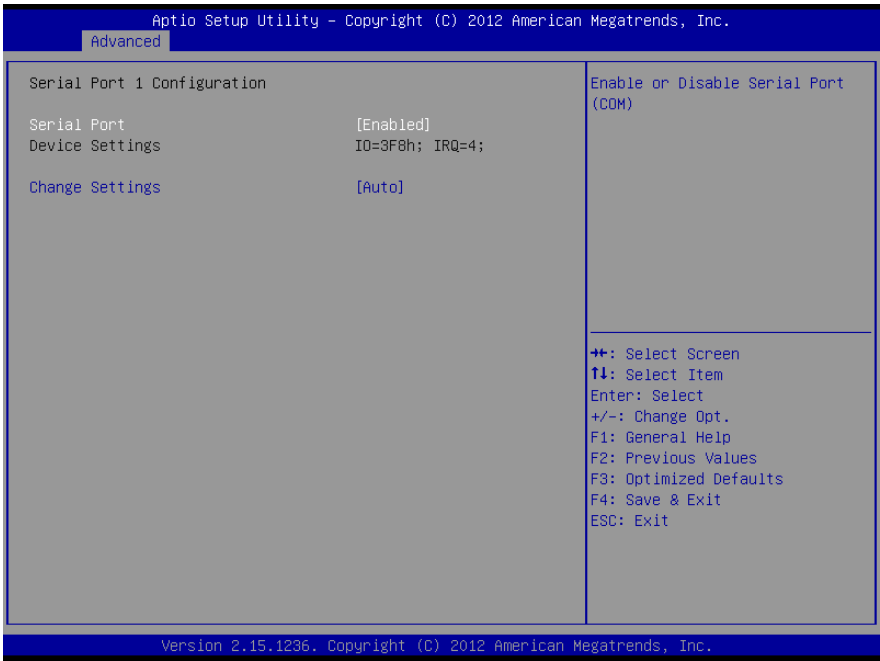

Options summary: (default setting)

Serial Port	Disabled	
	<b>Enabled</b>	
En/Disable specified serial port.		
Change Settings	<b>Auto</b>	
	IO=3F8h; IRQ=4;	
	IO=3F8h; IRQ=3,4,5,6,7,9,10,11,12;	
	IO=2F8h; IRQ=3,4,5,6,7,9,10,11,12;	
	IO=3E8h; IRQ=3,4,5,6,7,9,10,11,12;	
	IO=2E8h; IRQ=3,4,5,6,7,9,10,11,12;	
Select a resource setting for Super IO device.		

### 3.4.7.2 Super IO Configuration: Serial Port 2 Configuration

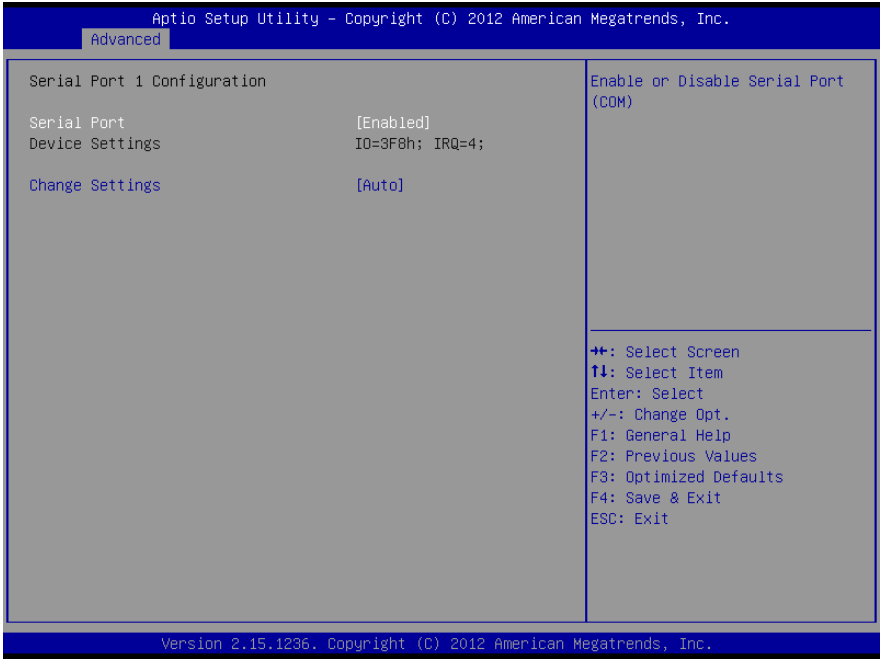

Options summary: (default setting)

Serial Port	Disabled	
	Enabled	
En/Disable specified serial port.		
Change Settings	Auto	
	IO=2F8h; IRQ=3;	
	IO=3F8h; IRQ=3,4,5,6,7,9,10,11,12;	
	IO=2F8h; IRQ=3,4,5,6,7,9,10,11,12;	
	IO=3E8h; IRQ=3,4,5,6,7,9,10,11,12;	
	IO=2E8h; IRQ=3,4,5,6,7,9,10,11,12;	
Select a resource setting for Super IO device.		



Device Type	RS232	
	RS422	
	RS485	
Configure COM2 operated as RS232, RS422 or RS485.		

### 3.4.7.3 Super IO Configuration: Serial Port 3 Configuration

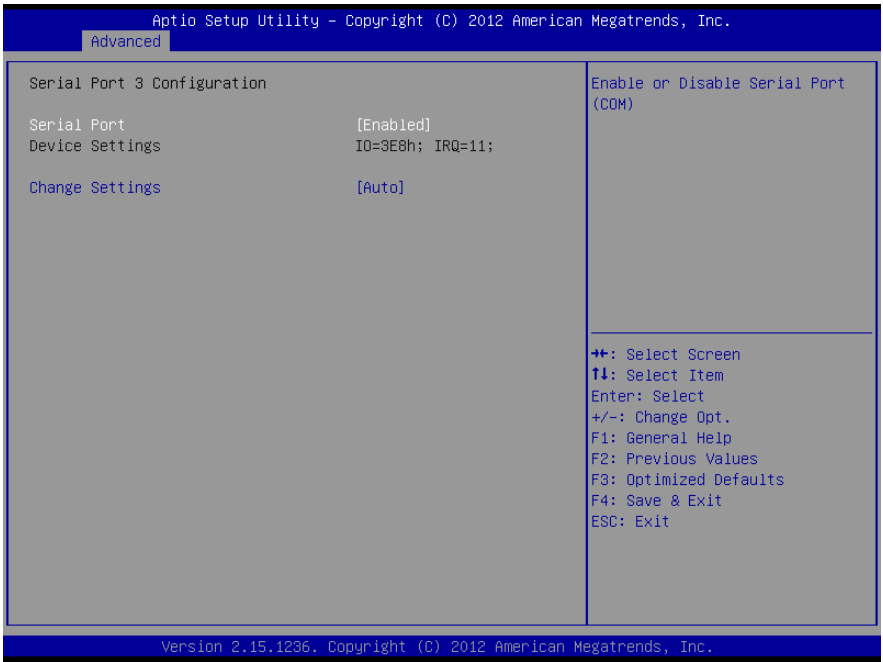

Options summary: (default setting)

Serial Port	Disabled	
	<b>Enabled</b>	
En/Disable specified serial port.		
Change Settings	<b>Auto</b>	
	IO=3E8h; IRQ=11;	
	IO=3F8h; IRQ=3,4,5,6,7,9,10,11,12;	
	IO=2F8h; IRQ=3,4,5,6,7,9,10,11,12;	
	IO=3E8h; IRQ=3,4,5,6,7,9,10,11,12;	
	IO=2E8h; IRQ=3,4,5,6,7,9,10,11,12;	
Select a resource setting for Super IO device.		

### 3.4.7.4 Super IO Configuration: Serial Port 4 Configuration

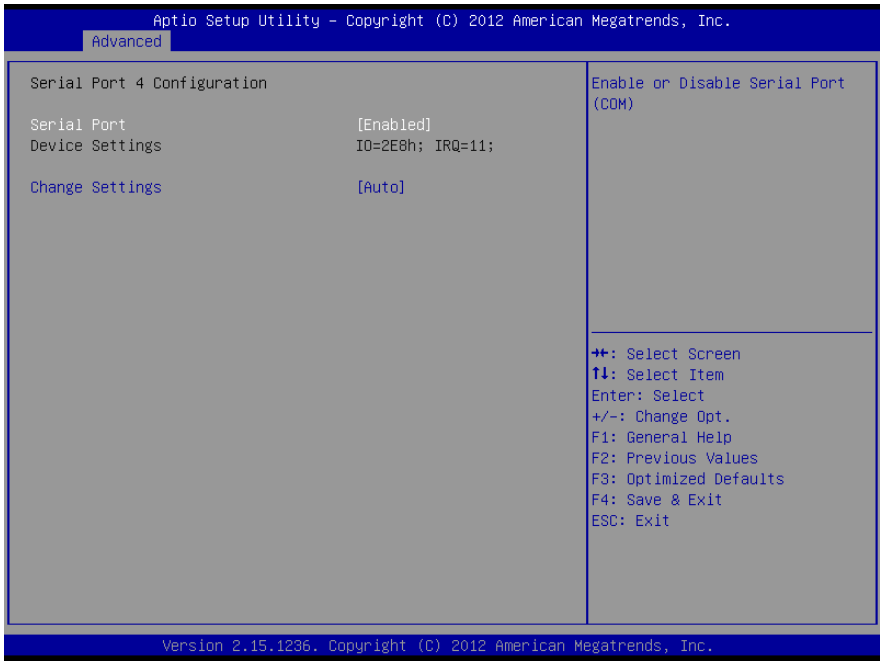

Options summary: (default setting)

Serial Port	Disabled	
	<b>Enabled</b>	
En/Disable specified serial port.		
Change Settings	<b>Auto</b>	
	IO=2E8h; IRQ=11;	
	IO=3F8h; IRQ=3,4,5,6,7,9,10,11,12;	
	IO=2F8h; IRQ=3,4,5,6,7,9,10,11,12;	
	IO=3E8h; IRQ=3,4,5,6,7,9,10,11,12;	
	IO=2E8h; IRQ=3,4,5,6,7,9,10,11,12;	
Select a resource setting for Super IO device.		

### 3.5 Setup submenu: Chipset

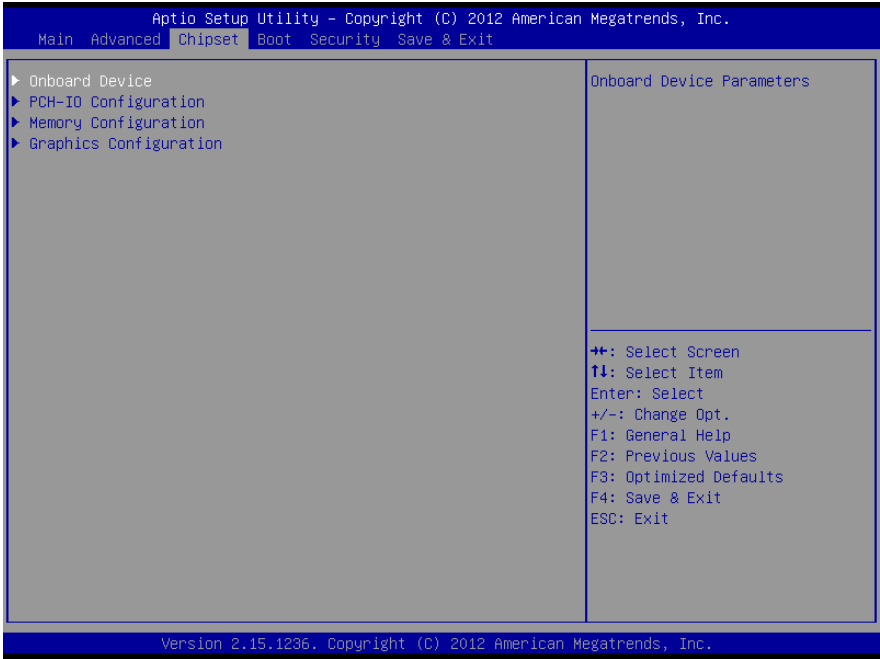

Options summary: **(default setting)**

Onboard Device		
Configure Onboard Devices		
PCI-IO Configuration		
South Bridge Parameters		
Memory Configuration		
Memory Parameters		
Graphic Configuration		
Graphic Parameters		

### 3.5.1 Chipset: Onboard Device

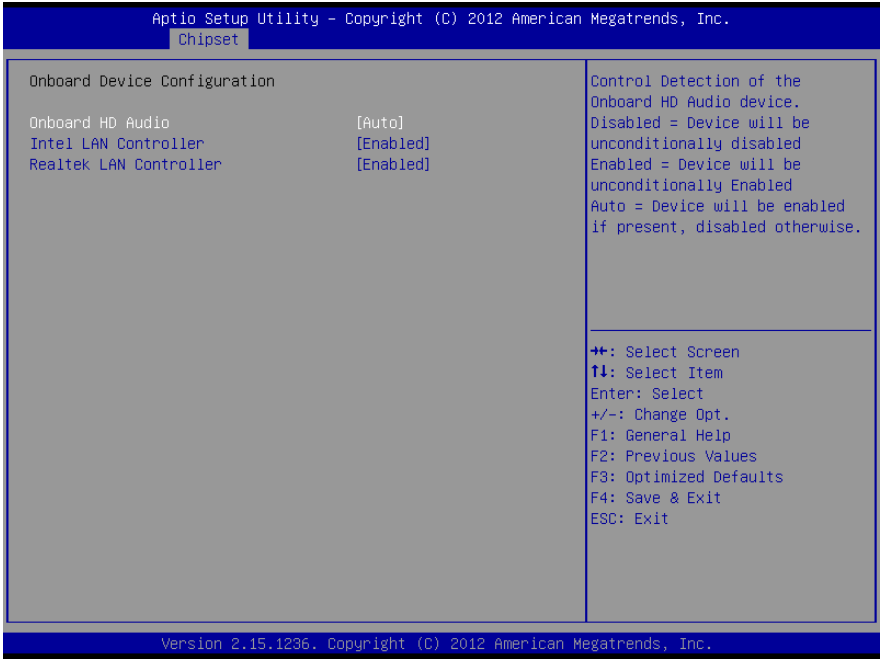

Options summary: (default setting)

Onboard HD Audio	Disabled	
	Enabled	
	<b>Auto</b>	
En/Disabled HD Audio controller.		
Intel LAN Controller	<b>Enabled</b>	
	Disabled	
En/Disabled Intel i82579 NIC		
Realtek LAN Controller	<b>Enabled</b>	
	Disabled	
En/Disabled Realtek RTL8111E NIC		

### 3.5.2 Chipset: PCH-IO Configuration

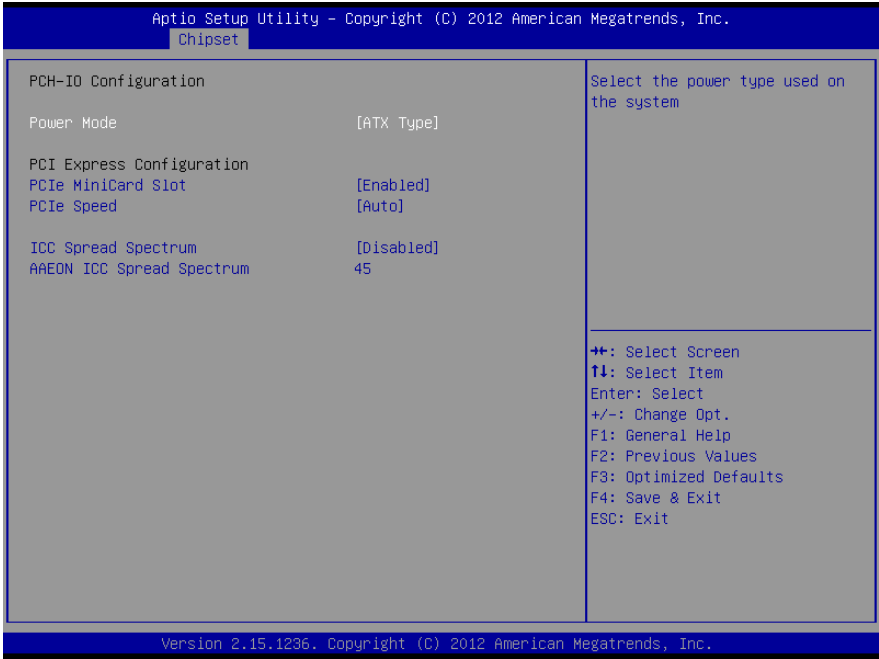

Options summary: (default setting)

Power Mode	128MB	
	256MB	
Select the power type used on the system		
PCIe MiniCard Slot	Disabled	
	Enabled	
Control the PCI Express Root Port.		
PCIe Speed	Auto	
	Gen1	
	Gen2	
Select PCI Express port speed. Some PCIe cards must set to Gen1 for operation.		

ICC Spread Spectrum	Disabled	
	Enabled	
Enabled or Disable Clock spread spectrum control		
AAEON ICC Spread Spectrum	0 to 50	
	45	
Spread spectrum level, From 0(0%) to 50(0.5%)		

### 3.5.3 Chipset: Memory Configuration

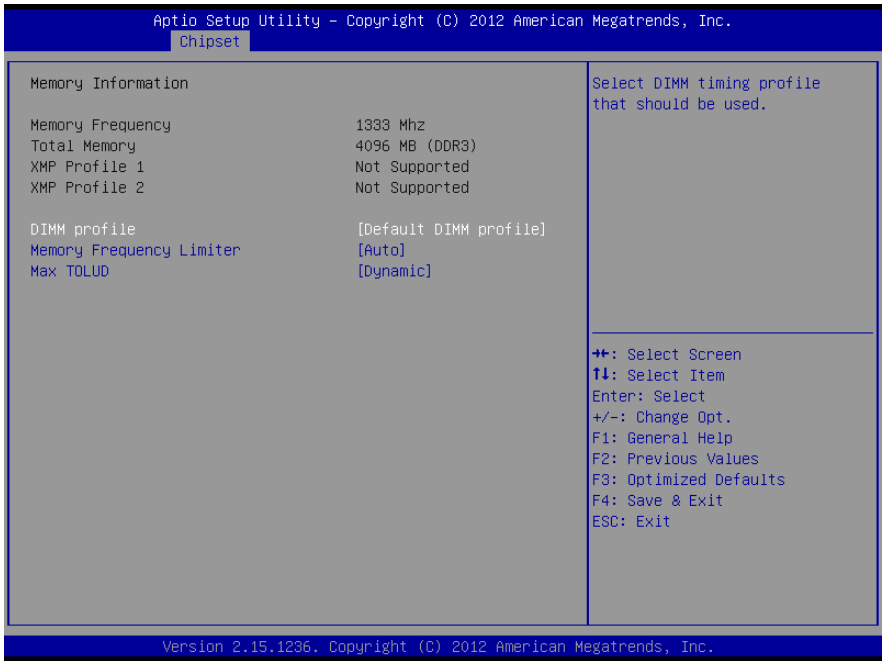

Options summary: (default setting)

DIMM Profile	Default DIMM profile	
	XMP Profile 1	
	XMP Profile 2	
Select DIMM timing profile that should be used		
Memory Frequency Limiter	Auto	
	1067	
	1333	
	1600	
Maximum Memory Frequency Selections in Mhz.		
Max TOLUD	Dynamic	



	1 GB	
	1.25 GB	
	1.5 GB	
	1.75 GB	
	2 GB	
	2.25 GB	
	2.5 GB	
	2.75 GB	
	3 GB	
	3.25 GB	
Maximum Value of TOLUD. Dynamic assignment would adjust TOLUD automatically based on largest MMIO length of install graphic controller.		

### 3.5.4 Chipset: Graphic Configuration

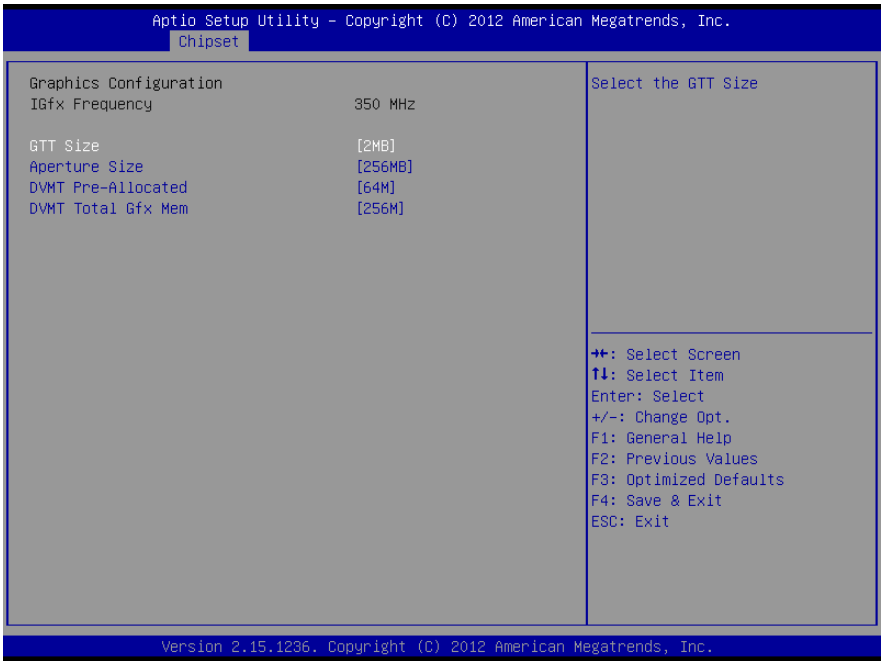

Options summary: (default setting)

GTT Size	1MB	
	<b>2MB</b>	
Select the GTT Size		
Aperture Size	128MB	
	<b>256MB</b>	
	512MB	
Select the Aperture Size		
DVMT Pre-Allocated	<b>64MB</b>	
	32MB~1024MB	

Select DVMT 5.0 Pre-Allocated (Fixed) Graphics Memory size used by the Internal Graphics Device.

DVMT Total Gfx Mem	128MB	
	<b>256MB</b>	
	Max	

Select DVMT 5.0 Total Graphic Memory size used by the Internal Graphics Device.

### 3.6 Setup submenu: Boot

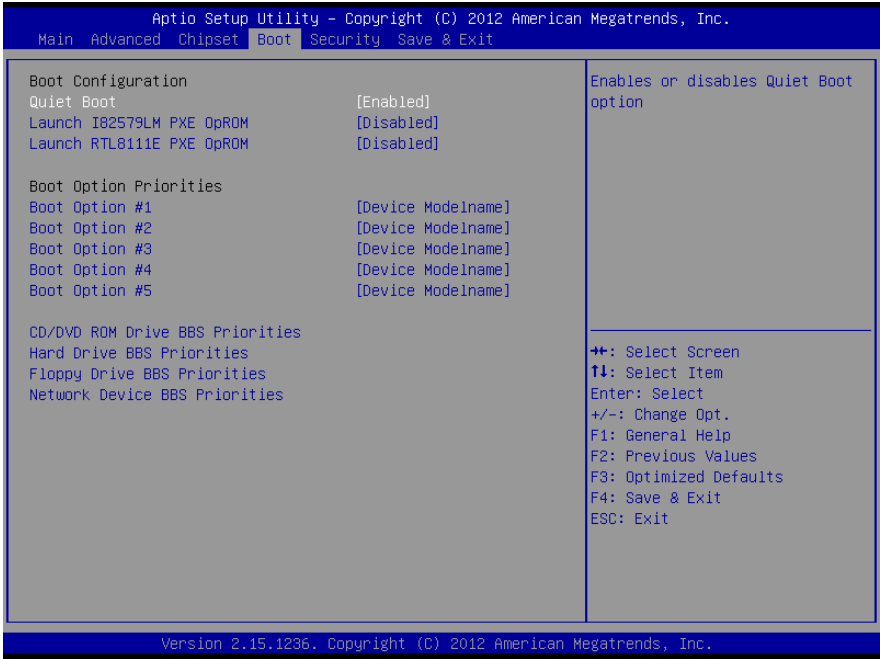

Options summary: (default setting)

Quiet Boot	Disabled	
	Enabled	
En/Disable showing boot logo.		
Launch I82579LM/ RTL8111E PXE OpROM	Disabled	
	Enabled	
En/Disable PXE boot for I82579LM/RTL8111E LAN		
Boot Option #X/ XXXX Drive BBS Priorities		
The order of boot priorities.		

### 3.6.1 Boot: BBS Priorities

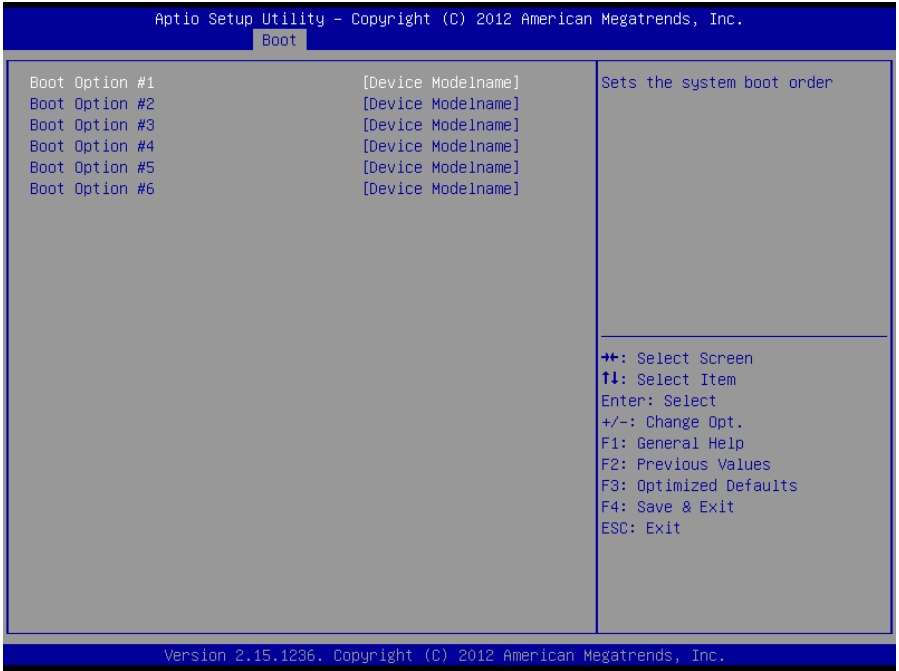

Options summary: (default setting)

Boot Option #x	Disabled	
	Device name	
Sets the system boot order		

### 3.7 Security

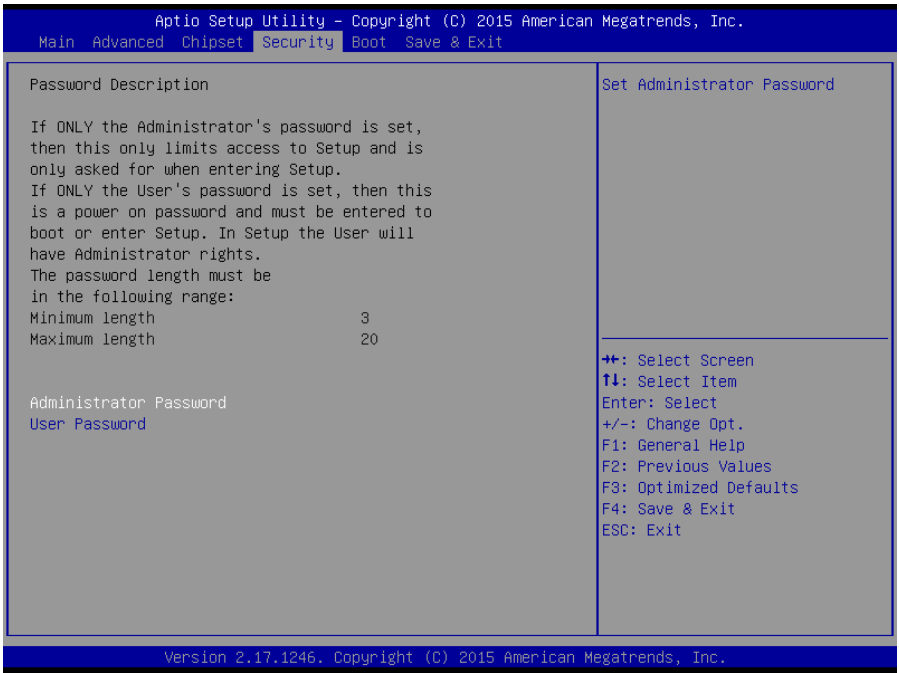

Options summary: (*default setting*)

Administrator Password/	<i>Not set</i>	
User Password		

#### Change User/Administrator Password

You can set a User Password once an Administrator Password is set. The password will be required during boot up, or when the user enters the Setup utility. Please Note that a User Password does not provide access to many of the features in the Setup utility.

Select the password you wish to set, press Enter to open a dialog box to enter your password (you can enter no more than six letters or numbers). Press Enter to confirm your entry, after which you will be prompted to retype your password for a final

confirmation. Press Enter again after you have retyped it correctly.

## Removing the Password

Highlight this item and type in the current password. At the next dialog box press Enter to disable password protection.

### 3.8 Setup submenu: Save & Exit

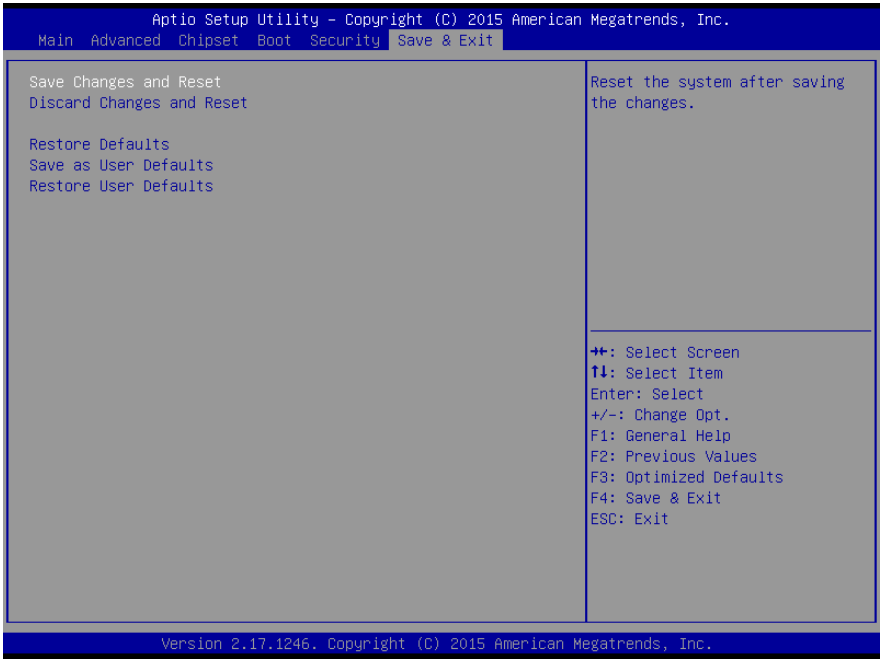

Options summary: **(default setting)**

Save Changes and Reset		
Reset the system after saving the changes		
Discard Changes and Reset		
Reset system setup without saving any changes		
Restore Defaults		
Restore/Load Default values for all the setup options.		
Save as User Defaults		
Save the changes done so far as User Defaults		
Restore User Defaults		
Restore the User Defaults to all the setup options		



# Chapter 4

---

Drivers Installation

## 4.1 Product CD/DVD

---

The AEC-6637 comes with a product DVD that contains all the drivers and utilities you need to setup your product. Insert the DVD and follow the steps in the autorun program to install the drivers.

In case the program does not start, follow the sequence below to install the drivers.

### Step 1 – Install Chipset Driver

1. Open the **STEP1 - Chipset** folder and select your OS
2. Open the **.exe** file in the folder
3. Follow the instructions
4. Drivers will be installed automatically

### Step 2 – Install Graphic Driver

1. Open the **STEP2 - VGA** folder and select your OS
2. Open the **Setup.exe** file in the folder
3. Follow the instructions
4. Drivers will be installed automatically

#### Note 1:

- This motherboard supports VGA and LVDS display devices. In Single Display mode, use the hot keys to switch between VGA to LVDS device or vice versa. By default, press **<Ctrl>+<Alt>+<F1>** to switch to VGA device and press **<Ctrl>+<Alt>+<F3>** to switch to LVDS device.
- Before removing the current display device, connect the display device that you want to use, and then press the hot keys to switch to that device.

**Note 2:** If you are using Windows XP, install **dotnet35.exe** first.

### Step 3 – Install LAN 1 Driver

1. Open the **STEP3 – LAN1** folder and select your OS
2. Open the **.exe** file in the folder
3. Follow the instructions
4. Drivers will be installed automatically

### Step 4 – Install LAN 2 Driver

1. Open the **STEP4 – LAN2** folder and select your OS
2. Open the **setup.exe** file in the folder
3. Follow the instructions
4. Drivers will be installed automatically

### Step 5 – Install Audio Driver

1. Open the **STEP5 - Audio** folder and select your OS
2. Open the **Setup.exe** file in the folder
3. Follow the instructions
4. Drivers will be installed automatically

### Step 6 – Install ME Driver

1. Open the **STEP6 - ME** folder and select your OS
2. Open the **.exe** file in the folder
3. Follow the instructions
4. Drivers will be installed automatically

### Step 7 – Install RAID & AHCI Driver

Please refer to Appendix C

## Step 8 – Install USB 3.0 Driver (Windows 7 only)

1. Open the **STEP8 – USB3.0** folder and select your OS
2. Open the **Setup.exe** file in the folder
3. Follow the instructions
4. Drivers will be installed automatically

## Step 9 – Install Serial Port Driver (Optional)

For Fintek drivers:

1. Open the **STEP9 – Serial Port Driver (optional)** folder followed by the **FintekT4R8** folder
2. Open the **Setup.exe** file in the folder
3. Follow the instructions
4. Drivers will be installed automatically

For ITE drivers:

For Windows 7:

1. Change User Account Control settings to **Never notify**

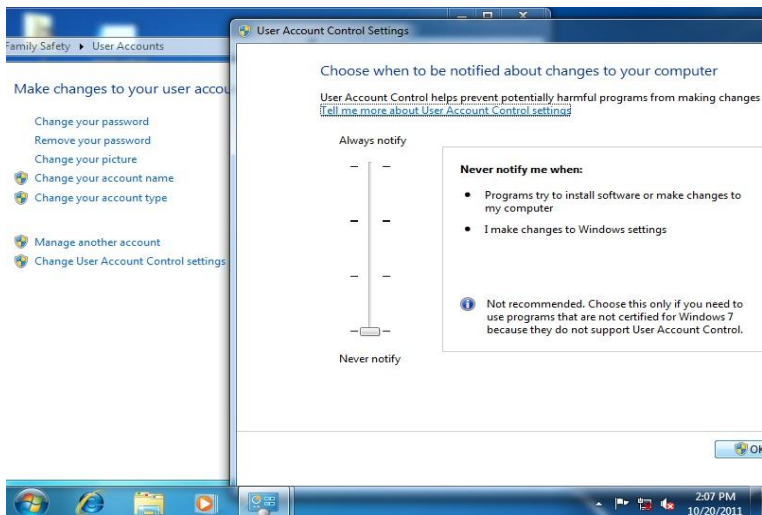

## 2. Reboot and log in as administrator

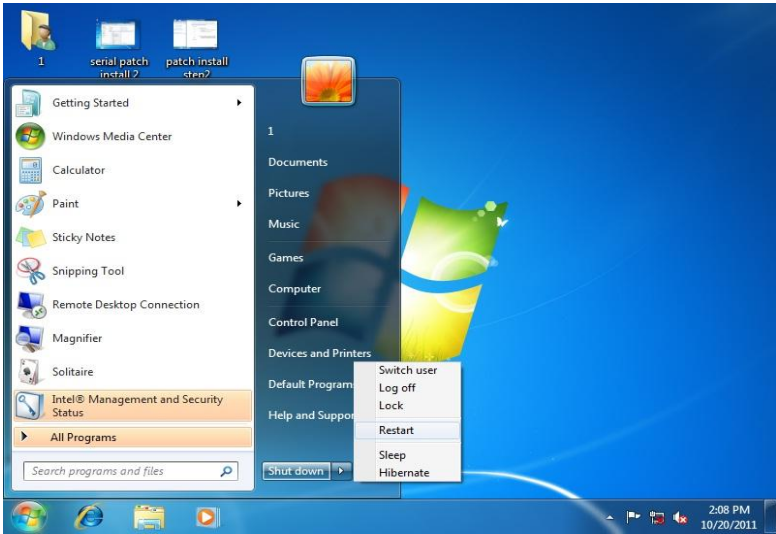

## 3. Run patch.bat as administrator

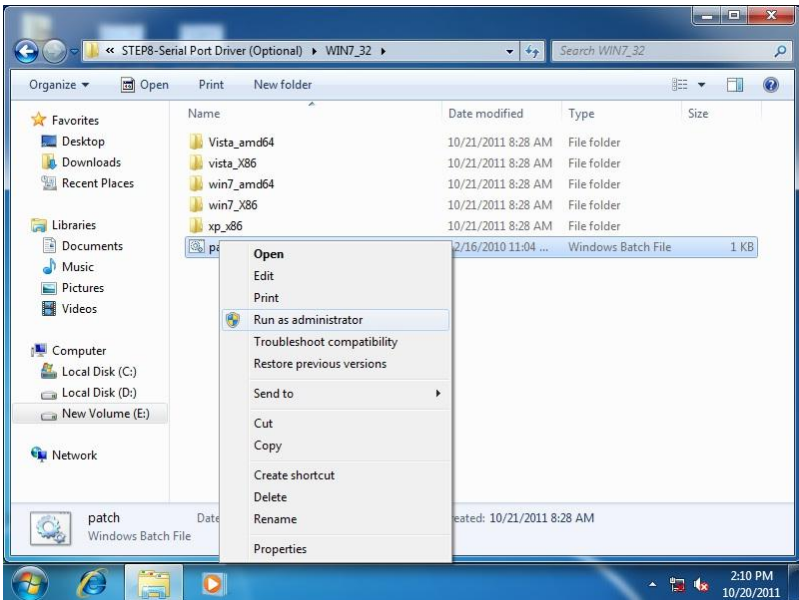

# Appendix A

---

## Watchdog Timer Programming

## A.1 Watchdog Timer Programming

AEC-6637 utilizes ITE IT8728F chipset as its watchdog timer controller.

Below are the procedures to complete its configuration and the AAEON initial watchdog timer program is also attached based on which you can develop customized program to fit your application.

### Configuring Sequence Description

After the hardware reset or power-on reset, the ITE 8728F enters the normal mode with all logical devices disabled except KBC. The initial state (enable bit ) of this logical device (KBC) is determined by the state of pin 121 (DTR1#) at the falling edge of the system reset during power-on reset.

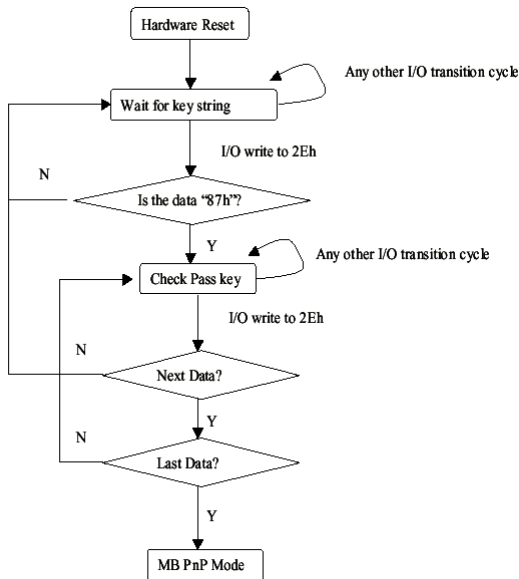

There are three steps to complete the configuration setup: (1) Enter the MB PnP Mode; (2) Modify the data of configuration registers; (3) Exit the MB PnP Mode. Undesired result may occur if the MB PnP Mode is not exited normally.

### (1) Enter the MB PnP Mode

To enter the MB PnP Mode, four special I/O write operations are to be performed during Wait for Key state. To ensure the initial state of the key-check logic, it is necessary to perform four write operations to the Special Address port (2EH). Two different enter keys are provided to select configuration ports (2Eh/2Fh) of the next step.

	<b>Address Port</b>	<b>Data Port</b>
87h, 01h, 55h, 55h:	2Eh	2Fh

### (2) Modify the Data of the Registers

All configuration registers can be accessed after entering the MB PnP Mode. Before accessing a selected register, the content of Index 07h must be changed to the LDN to which the register belongs, except some Global registers.

### (3) Exit the MB PnP Mode

Set bit 1 of the configure control register (Index=02h) to 1 to exit the MB PnP Mode.

## WatchDog Timer Configuration Registers

<b>LDN</b>	<b>Index</b>	<b>R/W</b>	<b>Reset</b>	<b>Configuration Register or Action</b>
All	02H	W	N/A	Configure Control
07H	71H	R/W	00H	WatchDog Timer Control Register
07H	72H	R/W	00H	WatchDog Timer Configuration Register
07H	73H	R/W	00H	WatchDog Timer Time-out Value Register

### Configure Control (Index=02h)

This register is write only. Its values are not sticky; that is to say, a hardware reset will automatically clear the bits, and does not require the software to clear them.



Bit	Description
7-2	Reserved
1	Returns to the Wait for Key state. This bit is used when the configuration sequence is completed
0	Resets all logical devices and restores configuration registers to their power-on states.

WatchDog Timer Control Register (Index=71h, Default=00h)

Bit	Description
7	WDT is reset upon a CIR interrupt
6	WDT is reset upon a KBC (mouse) interrupt
5	WDT is reset upon a KBC (keyboard) interrupt
4	WDT is reset upon a read or a write to the Game Port base address
3-2	Reserved
1	Force Time-out. This bit is self-clearing
0	WDT Status 1: WDT value reaches 0. 0: WDT value is not 0

WatchDog Timer Configuration Register (Index=72h, Default=00h)

Bit	Description
7	WDT Time-out value select 1: Second 0: Minute
6	WDT output through KRST (pulse) enable
5-4	Reserved
3-0	Select the interrupt level <sup>Note</sup> for WDT

WatchDog Timer Time-out Value Register (Index=73h, Default=00h)

Bit	Description
7-0	WDT Time-out value 7-0

## A.2 ITE8728F Watchdog Timer Initial Program

---

```
.MODEL SMALL
```

```
.CODE
```

Main:

```
CALL Enter_Configuration_mode
```

```
CALL Check_Chip
```

```
mov cl, 7
```

```
call Set_Logic_Device
```

```
;time setting
```

```
mov cl, 10 ; 10 Sec
```

```
dec al
```

Watch\_Dog\_Setting:

```
;Timer setting
```

```
mov al, cl
```

```
mov cl, 73h
```

```
call Superio_Set_Reg
```

```
;Clear by keyboard or mouse interrupt
```

```
mov al, 0f0h
```

```
mov cl, 71h
```

```
call Superio_Set_Reg
```

```
;unit is second.
```

```
mov al, 0C0H
```

```
mov cl, 72h
```

```
call Superio_Set_Reg
```

```
; game port enable
```

```
mov cl, 9
```

```
call Set_Logic_Device
```

Initial\_OK:

CALL Exit\_Configuration\_mode

MOV AH,4Ch

INT 21h

Enter\_Configuration\_Mode PROC NEAR

MOV SI,WORD PTR CS:[Offset Cfg\_Port]

MOV DX,02Eh

MOV CX,04h

Init\_1:

MOV AL,BYTE PTR CS:[SI]

OUT DX,AL

INC SI

LOOP Init\_1

RET

Enter\_Configuration\_Mode ENDP

Exit\_Configuration\_Mode PROC NEAR

MOV AX,0202h

CALL Write\_Configuration\_Data

RET

Exit\_Configuration\_Mode ENDP

Check\_Chip PROC NEAR

MOV AL,20h

```
CALL Read_Configuration_Data
CMP AL,87h
JNE Not_Initial
```

```
MOV AL,21h
CALL Read_Configuration_Data
CMP AL,12h
JNE Not_Initial
```

Need\_Initial:

```
STC
RET
```

Not\_Initial:

```
CLC
RET
Check_Chip ENDP
Read_Configuration_Data PROC NEAR
MOV DX,WORD PTR CS:[Cfg_Port+04h]
OUT DX,AL
MOV DX,WORD PTR CS:[Cfg_Port+06h]
IN AL,DX
RET
Read_Configuration_Data ENDP
```

```
Write_Configuration_Data PROC NEAR
MOV DX,WORD PTR CS:[Cfg_Port+04h]
OUT DX,AL
XCHG AL,AH
```

```
MOV DX,WORD PTR CS:[Cfg_Port+06h]
OUT DX,AL
RET
Write_Configuration_Data ENDP
```

```
Superio_Set_Reg proc near
push ax
MOV DX,WORD PTR CS:[Cfg_Port+04h]
mov al,cl
out dx,al
pop ax
inc dx
out dx,al
ret
Superio_Set_Reg endp.Set_Logic_Device proc near
Set_Logic_Device proc near
push ax
push cx
xchg al,cl
mov cl,07h
call Superio_Set_Reg
pop cx
pop ax
ret
Set_Logic_Device endp
```

```
;Select 02Eh->Index Port, 02Fh->Data Port
Cfg_Port DB 087h,001h,055h,055h
```

DW 02Eh,02Fh

## END Main

*Note: Interrupt level mapping*

0Fh-Dh: not valid

0Ch: IRQ12

.

.

03h: IRQ3

02h: not valid

01h: IRQ1

00h: no interrupt selected

# Appendix B









































---

I/O Information

## B.1 I/O Address Map

Input/output (IO)	
[00000000 - 0000001F]	Direct memory access controller
[00000000 - 000000CF]	PCI Bus
[00000010 - 0000001F]	Motherboard resources
[00000020 - 00000021]	Programmable interrupt controller
[00000022 - 0000003F]	Motherboard resources
[00000024 - 00000025]	Programmable interrupt controller
[00000028 - 00000029]	Programmable interrupt controller
[0000002C - 0000002D]	Programmable interrupt controller
[0000002E - 0000002F]	Motherboard resources
[00000030 - 00000031]	Programmable interrupt controller
[00000034 - 00000035]	Programmable interrupt controller
[00000038 - 00000039]	Programmable interrupt controller
[0000003C - 0000003D]	Programmable interrupt controller
[00000040 - 00000043]	System timer
[00000044 - 0000005F]	Motherboard resources
[0000004E - 0000004F]	Motherboard resources
[00000050 - 00000053]	System timer
[00000060 - 00000060]	Standard PS/2 Keyboard
[00000061 - 00000061]	Motherboard resources
[00000062 - 00000063]	Motherboard resources
[00000063 - 00000063]	Motherboard resources
[00000064 - 00000064]	Standard PS/2 Keyboard
[00000065 - 00000065]	Motherboard resources
[00000065 - 0000006F]	Motherboard resources
[00000067 - 00000067]	Motherboard resources
[00000070 - 00000070]	Motherboard resources
[00000070 - 00000077]	System CMOS/real time clock
[00000072 - 0000007F]	Motherboard resources
[00000080 - 00000080]	Motherboard resources
[00000080 - 00000080]	Motherboard resources
[00000081 - 00000091]	Direct memory access controller
[00000084 - 00000086]	Motherboard resources
[00000088 - 00000088]	Motherboard resources
[0000008C - 0000008E]	Motherboard resources
[00000090 - 0000009F]	Motherboard resources
[00000092 - 00000092]	Motherboard resources
[00000093 - 0000009F]	Direct memory access controller
[000000A0 - 000000A1]	Programmable interrupt controller
[000000A2 - 000000BF]	Motherboard resources
[000000A4 - 000000A5]	Programmable interrupt controller
[000000A8 - 000000A9]	Programmable interrupt controller
[000000AC - 000000AD]	Programmable interrupt controller



	[000000B0 - 000000B1]	Programmable interrupt controller
	[000000B2 - 000000B3]	Motherboard resources
	[000000B4 - 000000B5]	Programmable interrupt controller
	[000000B8 - 000000B9]	Programmable interrupt controller
	[000000BC - 000000BD]	Programmable interrupt controller
	[000000C0 - 000000DF]	Direct memory access controller
	[000000E0 - 000000EF]	Motherboard resources
	[000000F0 - 000000FF]	Numeric data processor
	[00000200 - 0000020F]	Motherboard resources
	[000002E8 - 000002EF]	Communications Port (COM4)
	[000002F8 - 000002FF]	Communications Port (COM2)
	[00000378 - 0000037F]	Printer Port (LPT1)
	[000003B0 - 000003BB]	Intel(R) HD Graphics 4000
	[000003C0 - 000003DF]	Intel(R) HD Graphics 4000
	[000003E8 - 000003EF]	Communications Port (COM3)
	[000003F8 - 000003FF]	Communications Port (COM1)
	[00000400 - 00000453]	Motherboard resources
	[00000454 - 00000457]	Motherboard resources
	[00000458 - 0000047F]	Motherboard resources
	[000004D0 - 000004D1]	Motherboard resources
	[000004D0 - 000004D1]	Programmable interrupt controller
	[00000500 - 0000057F]	Motherboard resources
	[00000680 - 0000069F]	Motherboard resources
	[00000A00 - 00000A1F]	Motherboard resources
	[00000A20 - 00000A2F]	Motherboard resources
	[00000A30 - 00000A3F]	Motherboard resources
	[00000D00 - 0000FFFF]	PCI Bus
	[00001000 - 00001003]	Motherboard resources
	[0000164E - 0000164F]	Motherboard resources
	[0000E000 - 0000E0FF]	Realtek PCIe GBE Family Controller
	[0000E000 - 0000EFFF]	Intel(R) 7 Series/C216 Chipset Family PCI Express Root Port 2 - 1E12
	[0000F000 - 0000F03F]	Intel(R) HD Graphics 4000
	[0000F040 - 0000F05F]	Intel(R) 7 Series/C216 Chipset Family SMBus Host Controller - 1E22
	[0000F060 - 0000F07F]	Intel(R) 7 Series Chipset Family SATA AHCI Controller
	[0000F0A0 - 0000F0A3]	Intel(R) 7 Series Chipset Family SATA AHCI Controller
	[0000F0B0 - 0000F0B7]	Intel(R) 7 Series Chipset Family SATA AHCI Controller
	[0000F0C0 - 0000F0C3]	Intel(R) 7 Series Chipset Family SATA AHCI Controller
	[0000F0D0 - 0000F0D7]	Intel(R) 7 Series Chipset Family SATA AHCI Controller
	[0000F0E0 - 0000F0E7]	Intel(R) Active Management Technology - SOL (COM5)
	[0000FFFF - 0000FFFF]	Motherboard resources



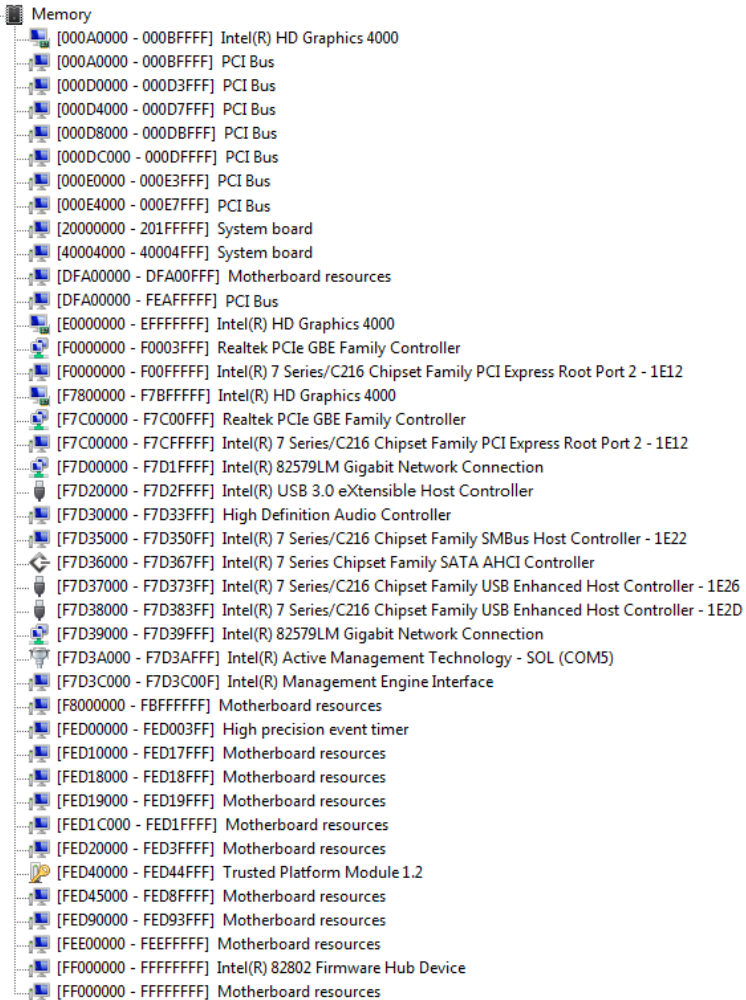



















## B.2 Memory Address Map



The image shows a screenshot of the Windows System Information tool, specifically the 'Memory' section. It displays a list of memory addresses and their corresponding hardware components. The list includes various system resources, PCI buses, and specific hardware components like graphics cards, network controllers, and audio controllers.

Memory Address	Hardware Component
[000A0000 - 000BFFFF]	Intel(R) HD Graphics 4000
[000A0000 - 000BFFFF]	PCI Bus
[000D0000 - 000D3FFF]	PCI Bus
[000D4000 - 000D7FFF]	PCI Bus
[000D8000 - 000DBFFF]	PCI Bus
[000DC000 - 000DFFFF]	PCI Bus
[000E0000 - 000E3FFF]	PCI Bus
[000E4000 - 000E7FFF]	PCI Bus
[20000000 - 201FFFFFF]	System board
[40004000 - 40004FFF]	System board
[DFA00000 - DFA00FFF]	Motherboard resources
[DFA00000 - FEAFFFFF]	PCI Bus
[E0000000 - EFFFFFFF]	Intel(R) HD Graphics 4000
[F0000000 - F0003FFF]	Realtek PCIe GBE Family Controller
[F0000000 - F00FFFFFF]	Intel(R) 7 Series/C216 Chipset Family PCI Express Root Port 2 - 1E12
[F7800000 - F7BFFFFFF]	Intel(R) HD Graphics 4000
[F7C00000 - F7C00FFF]	Realtek PCIe GBE Family Controller
[F7C00000 - F7CFFFFFF]	Intel(R) 7 Series/C216 Chipset Family PCI Express Root Port 2 - 1E12
[F7D00000 - F7D1FFFF]	Intel(R) 82579LM Gigabit Network Connection
[F7D20000 - F7D2FFFF]	Intel(R) USB 3.0 eXtensible Host Controller
[F7D30000 - F7D33FFF]	High Definition Audio Controller
[F7D35000 - F7D350FF]	Intel(R) 7 Series/C216 Chipset Family SMBus Host Controller - 1E22
[F7D36000 - F7D367FF]	Intel(R) 7 Series Chipset Family SATA AHCI Controller
[F7D37000 - F7D373FF]	Intel(R) 7 Series/C216 Chipset Family USB Enhanced Host Controller - 1E26
[F7D38000 - F7D383FF]	Intel(R) 7 Series/C216 Chipset Family USB Enhanced Host Controller - 1E2D
[F7D39000 - F7D39FFF]	Intel(R) 82579LM Gigabit Network Connection
[F7D3A000 - F7D3AFFF]	Intel(R) Active Management Technology - SOL (COM5)
[F7D3C000 - F7D3C00F]	Intel(R) Management Engine Interface
[F8000000 - FBFFFFFF]	Motherboard resources
[FED00000 - FED003FF]	High precision event timer
[FED10000 - FED17FFF]	Motherboard resources
[FED18000 - FED18FFF]	Motherboard resources
[FED19000 - FED19FFF]	Motherboard resources
[FED1C000 - FED1FFFF]	Motherboard resources
[FED20000 - FED3FFFF]	Motherboard resources
[FED40000 - FED44FFF]	Trusted Platform Module 1.2
[FED45000 - FED8FFFF]	Motherboard resources
[FED90000 - FED93FFF]	Motherboard resources
[FEE00000 - FEEFFFFFF]	Motherboard resources
[FF000000 - FFFFFFFF]	Intel(R) 82802 Firmware Hub Device
[FF000000 - FFFFFFFF]	Motherboard resources

## B.3 IRQ Mapping Chart

Interrupt request (IRQ)	
 (ISA) 0x00000000 (00)	System timer
 (ISA) 0x00000001 (01)	Standard PS/2 Keyboard
 (ISA) 0x00000003 (03)	Communications Port (COM2)
 (ISA) 0x00000004 (04)	Communications Port (COM1)
 (ISA) 0x00000008 (08)	System CMOS/real time clock
 (ISA) 0x0000000A (10)	Communications Port (COM4)
 (ISA) 0x0000000B (11)	Communications Port (COM3)
 (ISA) 0x0000000C (12)	Microsoft PS/2 Mouse
 (ISA) 0x0000000D (13)	Numeric data processor
 (PCI) 0x0000000F (15)	Intel(R) 7 Series/C216 Chipset Family SMBus Host Controller - 1E22
 (PCI) 0x00000010 (16)	Intel(R) 7 Series/C216 Chipset Family USB Enhanced Host Controller - 1E2D
 (PCI) 0x00000010 (16)	Intel(R) 7 Series/C216 Chipset Family PCI Express Root Port 1 - 1E10
 (PCI) 0x00000010 (16)	Intel(R) Management Engine Interface
 (PCI) 0x00000011 (17)	Intel(R) 7 Series/C216 Chipset Family PCI Express Root Port 2 - 1E12
 (PCI) 0x00000013 (19)	Intel(R) Active Management Technology - SOL (COM5)
 (PCI) 0x00000016 (22)	High Definition Audio Controller
 (PCI) 0x00000017 (23)	Intel(R) 7 Series/C216 Chipset Family USB Enhanced Host Controller - 1E26
 (PCI) 0xFFFFFFFFFA (-6)	Realtek PCIe GBE Family Controller
 (PCI) 0xFFFFFFFFFB (-5)	Intel(R) 82579LM Gigabit Network Connection
 (PCI) 0xFFFFFFFFFC (-4)	Intel(R) USB 3.0 eXtensible Host Controller
 (PCI) 0xFFFFFFFFFD (-3)	Intel(R) HD Graphics 4000
 (PCI) 0xFFFFFFFFFE (-2)	Intel(R) 7 Series Chipset Family SATA AHCI Controller

## B.4 DMA Channel Assignments

---



Direct memory access (DMA)



4 Direct memory access controller

# Appendix C

---

RAID & AHCI Settings

## C.1 Setting RAID

OS installation to SETUP RAID Mode

Step 1: Copy below files from "Driver CD -> Step7-RAID&AHCI\ WinXP\_32" to diskette.

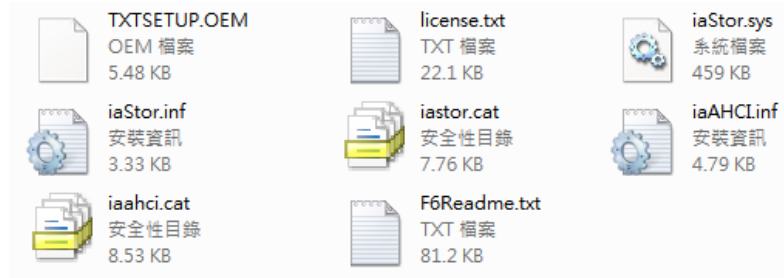

Step 2: Connect the USB Floppy drive to the board and insert the diskette from previous step.

Step 3: Configure SATA Controller to RAID mode in BIOS SETUP Menu: Advanced -> SATA Configuration -> SATA Mode -> RAID Mode

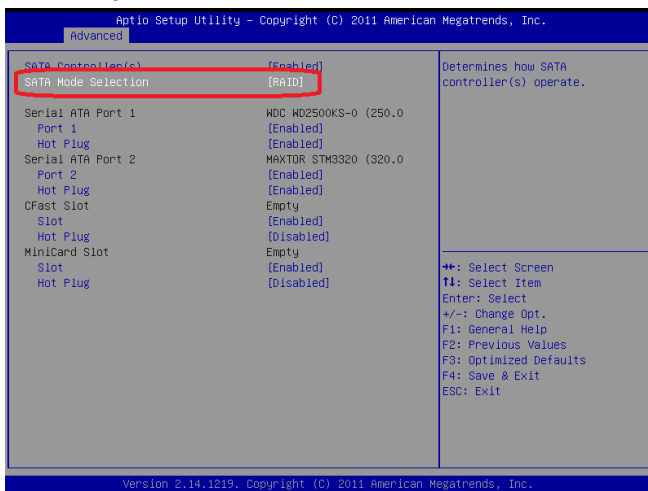

Step 4: Configure DVD/CD-ROM drive as the first boot device.

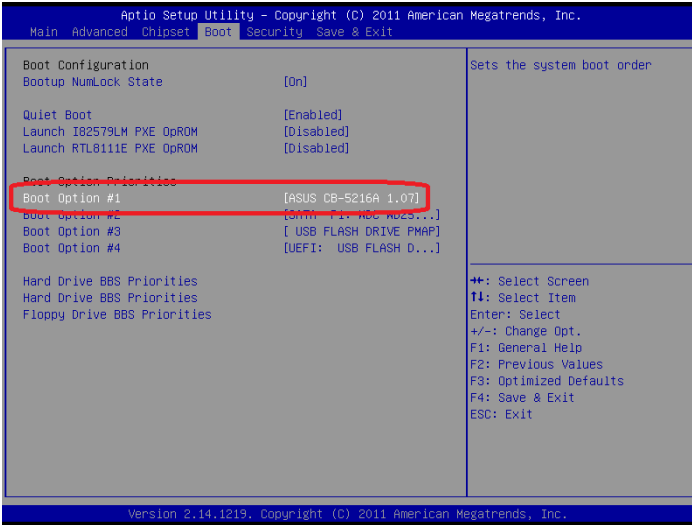

Step 5: Save changes and exit BIOS SETUP

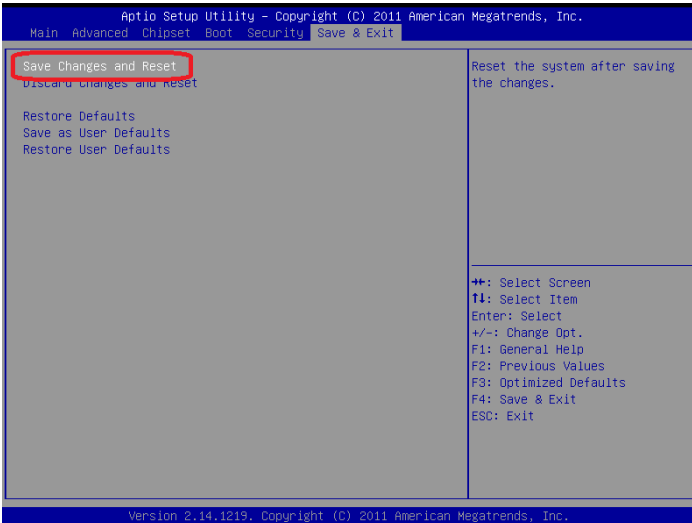

## Step 6: Press CTRL-I to enter RAID Configuration Utility

```

Intel(R) Rapid Storage Technology - Option ROM - 11.0.0.1339
Copyright(C) 2003-11 Intel Corporation. All Rights Reserved.

RAID Volumes:
None defined.

Physical Devices:
ID Device Model Serial # Size Type/Status(Vol ID)
0 WDC WD2500KS-00M WD-WCANKD571398 232.8GB Non-RAID Disk
1 MAXTOR STM332061 9SZ29FB8 298.0GB Non-RAID Disk
Press <CTRL-I> to enter Configuration Utility...

```

## Step 7: Choose "1. Create RAID Volume"

```

Intel(R) Rapid Storage Technology - Option ROM - 11.0.0.1339
Copyright(C) 2003-11 Intel Corporation. All Rights Reserved.
*****[ MAIN MENU ]*****
* 1. Create RAID Volume 4. Recovery Volume Options
* 2. Delete RAID Volume 5. Acceleration Options
* 3. Reset Disks to Non-RAID 6. Exit
*****[ DISK/VOLUME INFORMATION ]*****
* RAID Volumes:
* None defined.
* Physical Devices:
* ID Device Model Serial # Size Type/Status(Vol ID)
* 0 WDC WD2500KS-00M WD-WCANKD571398 232.8GB Non-RAID Disk
* 1 MAXTOR STM332061 9SZ29FB8 298.0GB Non-RAID Disk
*
*
*
*
*
*
*
*
*
*****
[**]-Select [ESC]-Exit [ENTER]-Select Menu

```



## Step 8 – Configure RAID parameters for the system

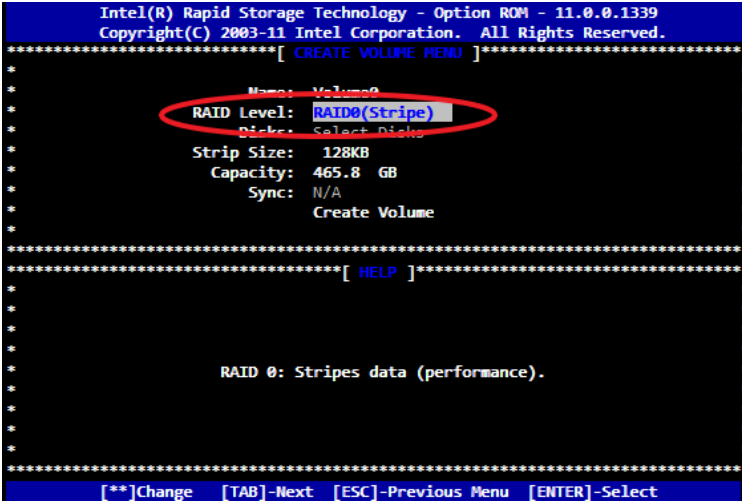

## Step 9 – Choose “Create Volume” and confirmed in next warning message.

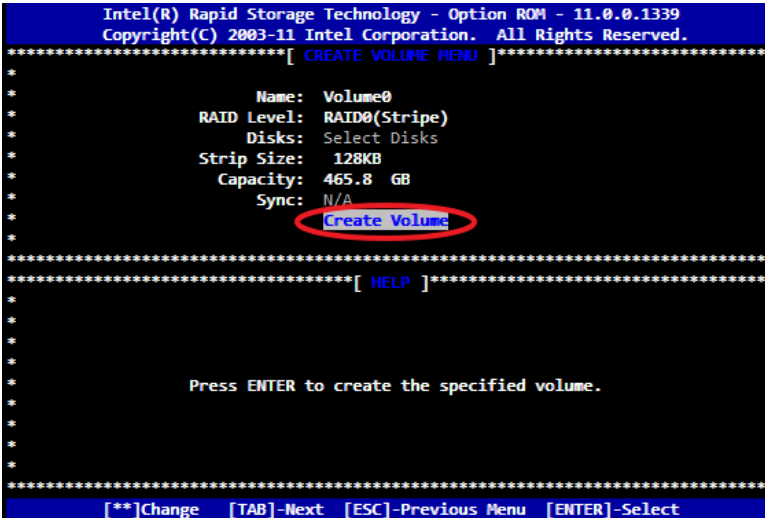

```
Intel(R) Rapid Storage Technology - Option ROM - 11.0.0.1339
Copyright(C) 2003-11 Intel Corporation. All Rights Reserved.
***** [ CREATE VOLUME MENU ] *****
*
*      Name: Volume0
*      RAID Level: RAID0(Stripe)
*      Disks: Select Disks
*      Strip Size: 128KB
*      Capacity: 465.8 GB
*      Sync: N/A
*
* *****
*      WARNING: ALL DATA ON SELECTED DISKS WILL BE LOST.
* *****
*      Are you sure you want to create this volume? (Y/N):
* *****
*
*      Press ENTER to create the specified volume.
*
* *****
*      [**]Change [TAB]-Next [ESC]-Previous Menu [ENTER]-Select
```

Step 10 – Exit RAID Configuration Utility and Reboot to DVD/CD-ROM device to install OS

Step 11 – Press “F6” to install RAID driver

```
Windows Setup
*****
Press F6 if you need to install a third party SCSI or RAID driver...
```

Step 12 – Press “S” to install RAID driver

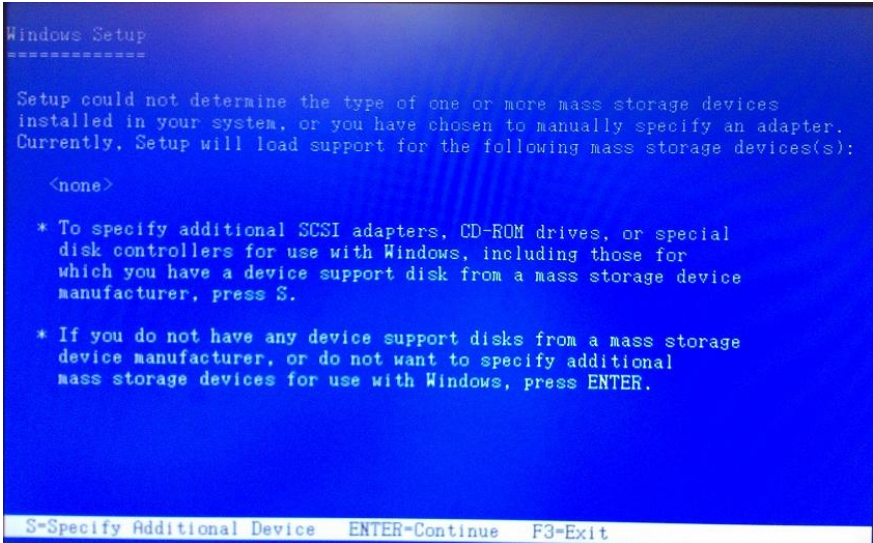

Step 13 – Choose “Intel(R) Mobile Express Chipset SATA RAID Controller”

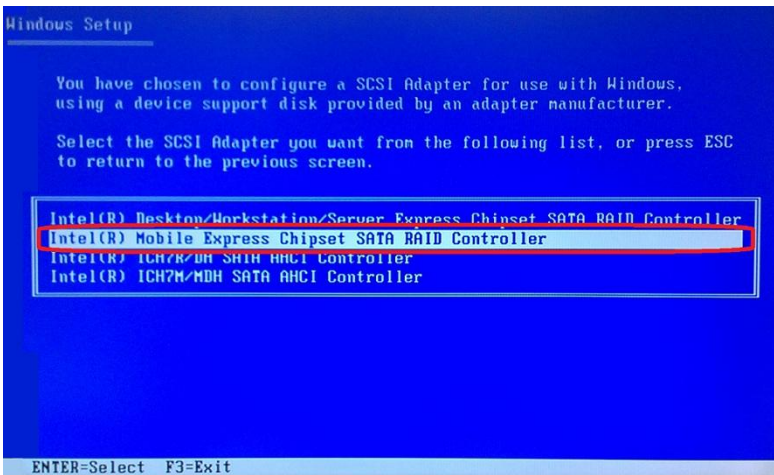

Step 14 – It will show the model you selected and then press "ENTER". Windows Setup will continue to install OS.

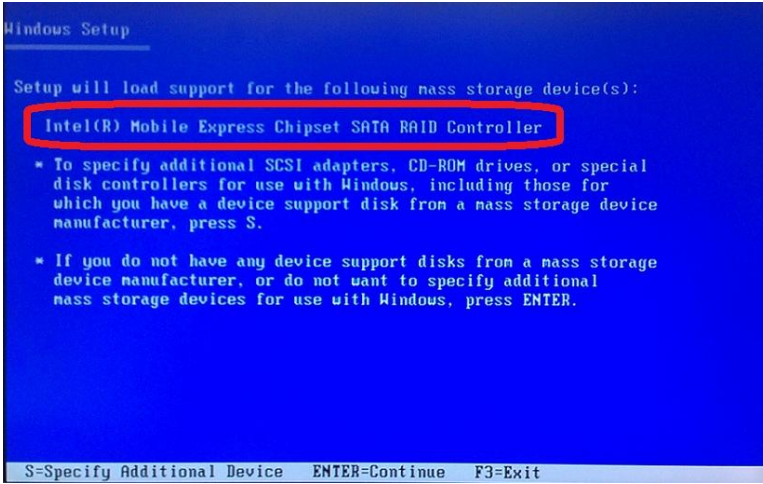

## C.2 Setting AHCI

OS installation to SETUP AHCI Mode

Step 1: Copy below files from "Driver CD -> Step7-RAID&AHCI\ WinXP\_32" to diskette.

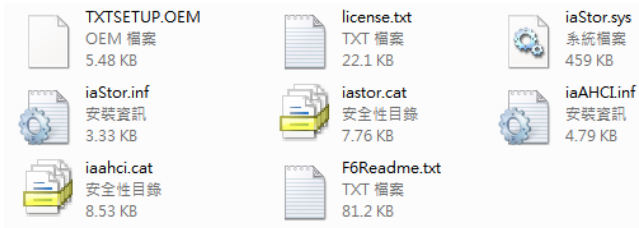

Step 2: Connect the USB Floppy drive to the board and insert the diskette from previous step.

Step 3: Configure SATA Controller to RAID mode in BIOS SETUP Menu: Advanced -> SATA Configuration -> SATA Mode -> AHCI Mode

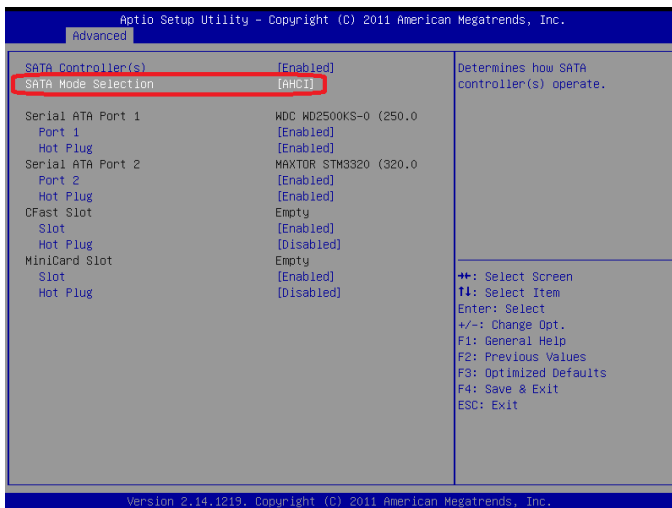

Step 4: Configure DVD/CD-ROM drive as the first boot device.

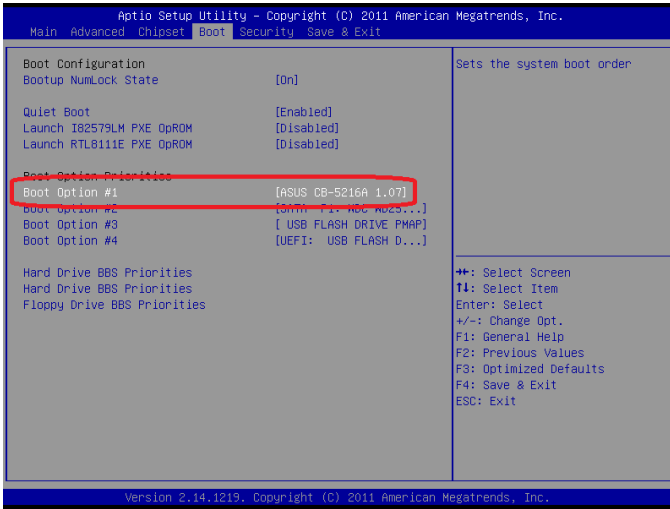

Step 5: Save changes and exit BIOS SETUP

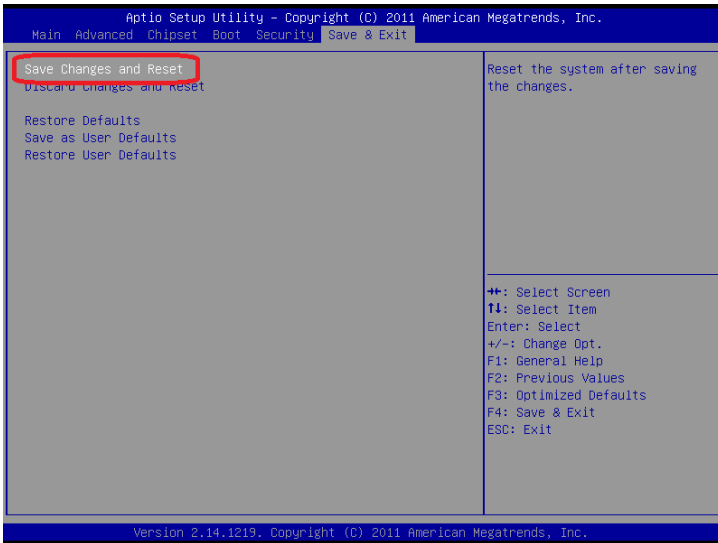

Step 6 – Boot to DVD/CD-ROM device to install OS

Step 7 – Press “F6” to install AHCI driver

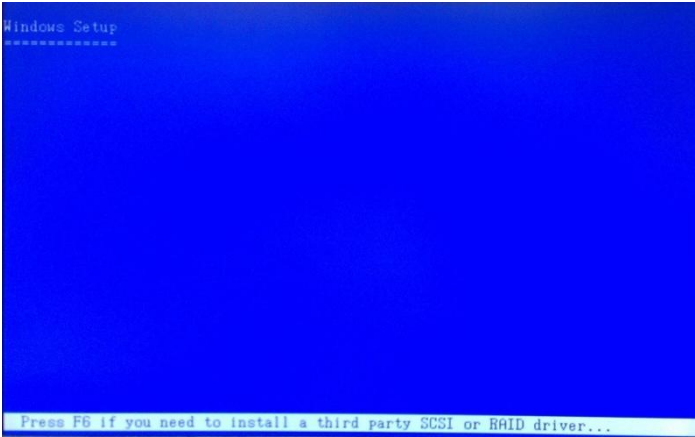

Step 8 – Press “S” to install AHCI driver

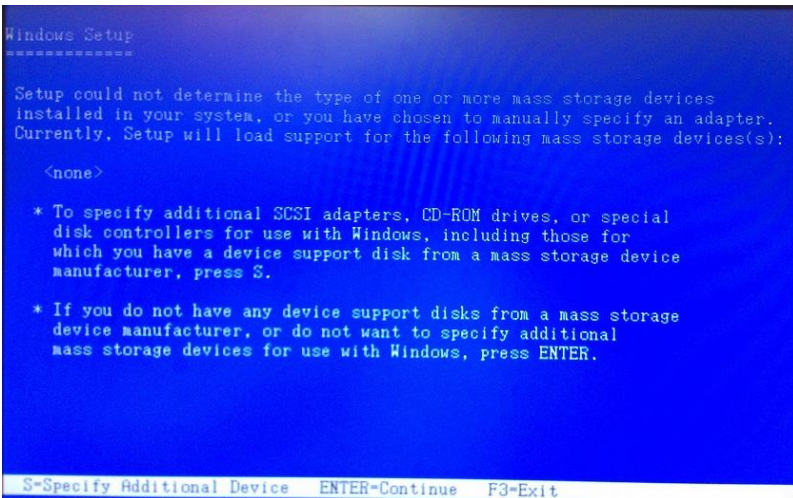

### Step 9 – Choose “Intel(R) 7 Series Chipset Family SATA AHCI Controller”

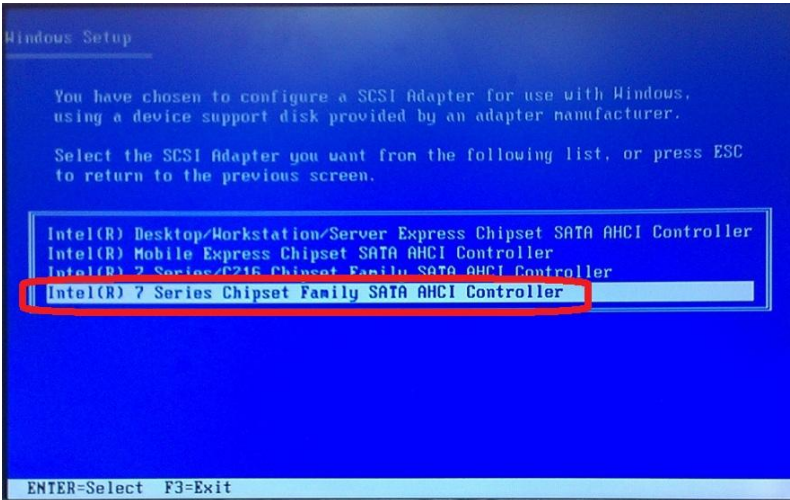

Step 10 – It will show the model you selected and then press “ENTER”. Windows Setup will continue to install OS.

