

# BOXER-6357VS

---

Railway Embedded Box PC

User's Manual 4<sup>th</sup> Ed

## Copyright Notice

---

This document is copyrighted, 2016. All rights are reserved. The original manufacturer reserves the right to make improvements to the products described in this manual at any time without notice.

No part of this manual may be reproduced, copied, translated, or transmitted in any form or by any means without the prior written permission of the original manufacturer. Information provided in this manual is intended to be accurate and reliable. However, the original manufacturer assumes no responsibility for its use, or for any infringements upon the rights of third parties that may result from its use.

The material in this document is for product information only and is subject to change without notice. While reasonable efforts have been made in the preparation of this document to assure its accuracy, AAEMON assumes no liabilities resulting from errors or omissions in this document, or from the use of the information contained herein.

AAEMON reserves the right to make changes in the product design without notice to its users.

## Acknowledgement

---

All other products' name or trademarks are properties of their respective owners.

- Microsoft Windows is a registered trademark of Microsoft Corp.
- Intel, Pentium, Celeron, and Xeon are registered trademarks of Intel Corporation
- Core, Atom are trademarks of Intel Corporation
- ITE is a trademark of Integrated Technology Express, Inc.
- IBM, PC/AT, PS/2, and VGA are trademarks of International Business Machines Corporation.

All other product names or trademarks are properties of their respective owners.

## Packing List

---

Before setting up your product, please make sure the following items have been shipped:

Item	Quantity
● BOXER-6357VS	1
● Wallmount bracket	2
● Screw (M2 x 3 mm)	3
● Screw (M4 x 6 mm)	5
● Drive bay keys	4
● Waterproof power kit	1
● M12 DC power kit	1
● M12 USB Y cable	1
● M12 COM cable	1
● M12 LAN cable	2
● Product DVD with User's Manual (in pdf) and drivers	1

If any of these items are missing or damaged, please contact your distributor or sales representative immediately.

## About this Document

---

This User's Manual contains all the essential information, such as detailed descriptions and explanations on the product's hardware and software features (if any), its specifications, dimensions, jumper/connector settings/definitions, and driver installation instructions (if any), to facilitate users in setting up their product.

Users may refer to the [AAEON.com](http://AAEON.com) for the latest version of this document.

## Safety Precautions

---

Please read the following safety instructions carefully. It is advised that you keep this manual for future references

1. All cautions and warnings on the device should be noted.
2. All cables and adapters supplied by AAEON are certified and in accordance with the material safety laws and regulations of the country of sale. Do not use any cables or adapters not supplied by AAEON to prevent system malfunction or fires.
3. Make sure the power source matches the power rating of the device.
4. Position the power cord so that people cannot step on it. Do not place anything over the power cord.
5. Always completely disconnect the power before working on the system's hardware.
6. No connections should be made when the system is powered as a sudden rush of power may damage sensitive electronic components.
7. If the device is not to be used for a long time, disconnect it from the power supply to avoid damage by transient over-voltage.
8. Always disconnect this device from any AC supply before cleaning.
9. While cleaning, use a damp cloth instead of liquid or spray detergents.
10. Make sure the device is installed near a power outlet and is easily accessible.
11. Keep this device away from humidity.
12. Place the device on a solid surface during installation to prevent falls
13. Do not cover the openings on the device to ensure optimal heat dissipation.
14. Watch out for high temperatures when the system is running.
15. Do not touch the heat sink or heat spreader when the system is running
16. Never pour any liquid into the openings. This could cause fire or electric shock.

17. As most electronic components are sensitive to static electrical charge, be sure to ground yourself to prevent static charge when installing the internal components. Use a grounding wrist strap and contain all electronic components in any static-shielded containers.
18. If any of the following situations arises, please the contact our service personnel:
  - i. Damaged power cord or plug
  - ii. Liquid intrusion to the device
  - iii. Exposure to moisture
  - iv. Device is not working as expected or in a manner as described in this manual
  - v. The device is dropped or damaged
  - vi. Any obvious signs of damage displayed on the device
19. **DO NOT LEAVE THIS DEVICE IN AN UNCONTROLLED ENVIRONMENT WITH TEMPERATURES BEYOND THE DEVICE'S PERMITTED STORAGE TEMPERATURES (SEE CHAPTER 1) TO PREVENT DAMAGE.**

### **Warning!**



This device complies with Part 15 FCC Rules. Operation is subject to the following two conditions: (1) this device may not cause harmful interference, and (2) this device must accept any interference received including interference that may cause undesired operation.

### **Caution:**

*There is a danger of explosion if the battery is incorrectly replaced. Replace only with the same or equivalent type recommended by the manufacturer. Dispose of used batteries according to the manufacturer's instructions and your local government's recycling or disposal directives.*

### **Attention:**

*Il y a un risque d'explosion si la batterie est remplacée de façon incorrecte. Ne la remplacer qu'avec le même modèle ou équivalent recommandé par le constructeur. Recycler les batteries usées en accord avec les instructions du fabricant et les directives gouvernementales de recyclage.*



## China RoHS Requirements (CN)

产品中有毒有害物质或元素名称及含量

AAEON Embedded Box PC/ Industrial System

部件名称	有毒有害物质或元素					
	铅 (Pb)	汞 (Hg)	镉 (Cd)	六价铬 (Cr(VI))	多溴联苯 (PBB)	多溴二苯醚 (PBDE)
印刷电路板 及其电子组件	○	○	○	○	○	○
外部信号 连接器及线材	○	○	○	○	○	○
外壳	○	○	○	○	○	○
中央处理器 与内存	○	○	○	○	○	○
硬盘	○	○	○	○	○	○
电源	○	○	○	○	○	○

O: 表示该有毒有害物质在该部件所有均质材料中的含量均在 SJ/T 11363-2006 标准规定的限量要求以下。

X: 表示该有毒有害物质至少在该部件的某一均质材料中的含量超出 SJ/T 11363-2006 标准规定的限量要求。

备注:

一、此产品所标示之环保使用期限, 系指在一般正常使用状况下。

二、上述部件物质中央处理器、内存、硬盘、电源为选购品。

## China RoHS Requirement (EN)

Poisonous or Hazardous Substances or Elements in Products  
AAEON Embedded Box PC/ Industrial System

Component	Poisonous or Hazardous Substances or Elements					
	Lead (Pb)	Mercury (Hg)	Cadmium (Cd)	Hexavalent Chromium (Cr(VI))	Polybrominated Biphenyls (PBB)	Polybrominated Diphenyl Ethers (PBDE)
PCB & Other Components	○	○	○	○	○	○
Wires & Connectors for External Connections	○	○	○	○	○	○
Chassis	○	○	○	○	○	○
CPU & RAM	○	○	○	○	○	○
Hard Disk	○	○	○	○	○	○
PSU	○	○	○	○	○	○

O: The quantity of poisonous or hazardous substances or elements found in each of the component's parts is below the SJ/T 11363-2006-stipulated requirement.

X: The quantity of poisonous or hazardous substances or elements found in at least one of the component's parts is beyond the SJ/T 11363-2006-stipulated requirement.

**Note:** The Environment Friendly Use Period as labeled on this product is applicable under normal usage only

# Table of Contents

---

<b>Chapter 1 - Product Specifications</b> .....	<b>1</b>
1.1 Specifications.....	2
<b>Chapter 2 – Hardware Information</b> .....	<b>5</b>
2.1 Dimensions .....	6
2.2 List of Jumpers .....	8
2.2.1 Clear CMOS Selection (JP1).....	9
2.2.2 Dry and Wet Contact Digital Output Power Selection (JP2)....	9
2.2.3 Dry and Wet Contact Digital Input Power Selection (JP3) .....	9
2.2.4 COM2/3 12V/5V/RI (JP4/5).....	9
2.2.5 AT/ATX Mode Selection (JP6) .....	10
2.3 List of Connectors.....	11
2.3.1 M12 Ethernet 1/2 (CN1/2) .....	12
2.3.2 Front Panel Connector (CN6).....	12
2.3.3 BIOS SPI Flash Header (CN7) .....	12
2.3.4 LCP Connector (CN18) .....	13
2.3.5 USB 3.0 Connector (CN22) .....	13
2.3.6 USB 2.0 Connector (CN23) .....	13
2.3.7 Digital Input/ Output (CN35).....	14
2.3.8 COM2/3 RS-232/422/485 Connector (CN38/39).....	17
2.3.9 Isolated COM1 RS-232/422/485 Connector (CN40).....	17
2.3.10 M12 USB 2.0 x 2 (USBM1).....	18
2.3.11 PSON Connector (PSONCN1).....	18
2.3.12 Power Switch (PWESW1) .....	18
2.3.13 Power Standby Connector (LEDSB5VCN12) .....	18
2.3.14 Power LED Connector (LEDCN19).....	19
2.3.15 MiniCard Slot (Full-MiniCard) (CN17).....	19

<b>Chapter 3 - AMI BIOS Setup .....</b>	<b>20</b>
3.1 System Test and Initialization .....	21
3.2 AMI BIOS Setup .....	22
3.3 Setup Submenu: Main .....	23
3.4 Setup Submenu: Advanced.....	24
3.4.2 Advanced: SATA Configuration .....	25
3.4.3 Advanced: USB Configuration.....	26
3.4.4 Advanced: Hardware Monitor .....	27
3.4.5 Advanced: Dynamic Digital IO Configuration.....	28
3.4.6 Advanced: AMT Configuration .....	29
3.4.7 Advanced: Super IO Configuration.....	30
3.4.7.1 Super IO Configuration: Serial Port 1 Configuration ..	31
3.4.7.2 Super IO Configuration: Serial Port 2 Configuration ..	32
3.4.7.3 Super IO Configuration: Serial Port 3 Configuration ..	33
3.4.7.4 Super IO Configuration: Serial Port 4 Configuration ..	34
3.4.7.5 Super IO Configuration: Power Saving Function .....	35
3.5 Setup submenu: Chipset.....	36
3.5.1 Chipset: PCH-IO Configuration.....	37
3.5.2 Chipset: System Agent (SA) Configuration.....	39
3.6 Setup submenu: Boot.....	40
3.7 Setup submenu: Security .....	41
3.8 Setup submenu: Save & Exit .....	42
<b>Chapter 4 – Drivers Installation.....</b>	<b>43</b>
4.1 Product CD/DVD .....	44
<b>Appendix A - Watchdog Timer Programming.....</b>	<b>52</b>
A.1 Watchdog Timer Initial Program .....	53
<b>Appendix B - I/O Information .....</b>	<b>58</b>
B.1 I/O Address Map .....	59

B.2	Memory Address Map .....	62
B.3	IRQ Mapping Chart.....	63
B.4	DMA Channel Assignments .....	76
<b>Appendix C – RAID &amp; AHCI Settings.....</b>		<b>77</b>
C.1	Setting RAID .....	78
C.2	Setting AHCI.....	88
<b>Appendix D – Digital I/O Ports .....</b>		<b>94</b>
D.1	DI/O Programming.....	95
D.2	Digital I/O Register.....	96
D.3	Digital I/O Sample Program.....	97

# Chapter 1

---

Product Specifications

## 1.1 Specifications

### System

- **Processor** Intel® Core™ i7-3517UE, up to 2.8 GHz
- **System Memory** DDR3 1333/1600 SODIMM x 2, up to. 16 GB (4 GB preinstalled)
- **Chipset** Intel® QM77
- **Display** DVI DVI-I x 1 (DVI-A x DVI-D)  
**Interface** VGA DB-15 x 1
- **Storage** CF-SATA CFast™ slot x 1  
**Device** HDD/SSD 2.5" Hot-Swappable/ Pluggable, RAID 0, 1 supported Drive Bay x 2 (Optionally expandable to 4 RAID 0, 1, 5, 10 supported HDDs)
- **Network** LAN Gigabit Ethernet  
Wireless Optional by MiniCard Wireless Module
- **Front I/O** USB Host USB 2.0 x 2 (M12, Female)  
LAN Gigabit LAN x 2 (M12, Female)  
Serial Port RS232/422/485 x 1 (M12, Female)  
Display —  
PoE —  
Others Power On/Off LED Switch x 1  
CFast™ Slot x 1 (Covered)  
SIM Slot x 1 (Covered)  
Removable HDD kit (SATA 6 Gb/s) x 2
- **Rear I/O** USB Host USB 3.0 Type A x 2  
LAN —

<b>Serial Port</b>	RS-232/422/485 x 2 (DB-9, non-isolated) RS-232/422/485 x 1 (DB-9, isolated)
<b>Display</b>	—
<b>PoE</b>	—
<b>Others</b>	Isolated digital input x 4 Isolated digital output x 2 Line-out x 1 Mic-in x 1 Power input connector (refer to Power Supply for details) Antenna opening x 3 (for WiFi, GPS, 3G/4G respectively)

● **Expansion**      **MiniCard**

Full-size MiniCard x 3

**Others**

SIM Socket x 3

● **Indicator**

System LED x 1 on Power On/Off

● **Power Requirement**

EN50155-certified

Supports ATX/AT, default ATX

DC-in with M12 Connector

Supports Over-voltage Protection

Supports Low-voltage Protection

Supports Short Circuit Protection

Nominal Input Voltage (VN)	EN50155 Input Range	AAEON Solution
	0.7(VN) – 1.25 (VN)	-
24	17 - 30	12 - 36
48	34 - 60	16.5 - 75
72	50 - 90	43 - 160
96	67 - 120	43 - 160
110	77 - 137	43 - 160

● **System Cooling**

Passive cooling



- **Mounting** Wall-mounted
- **Operating Temperature** -40 ~ 70°C (-40 ~ 158°F), 85°C (185°F) for 10 minutes only
- **Storage Temperature** -40 ~ 80°C (-40°F ~ 176°F)
- **Dimension (W x H x D)** 286 x 135 x 174.2 mm (112.60" x 68.58" x 53.15")
- **Anti-Vibration** EN61373 Standard
- **Anti-Shock** EN61373 Standard
- **Gross Weight** 8.26 kg (18.2 lb)
- **Net Weight** 6.9 kg (15.2 lb)
- **OS Support** Windows 8.1 (32/64-bit)  
Windows 7 (32/64-bit)  
Windows XP Pro (32-bit)  
Windows Embedded Standard 8  
Windows Embedded Standard 7  
Windows XP Embedded

# Chapter 2

---

Hardware Information

## 2.1 Dimensions

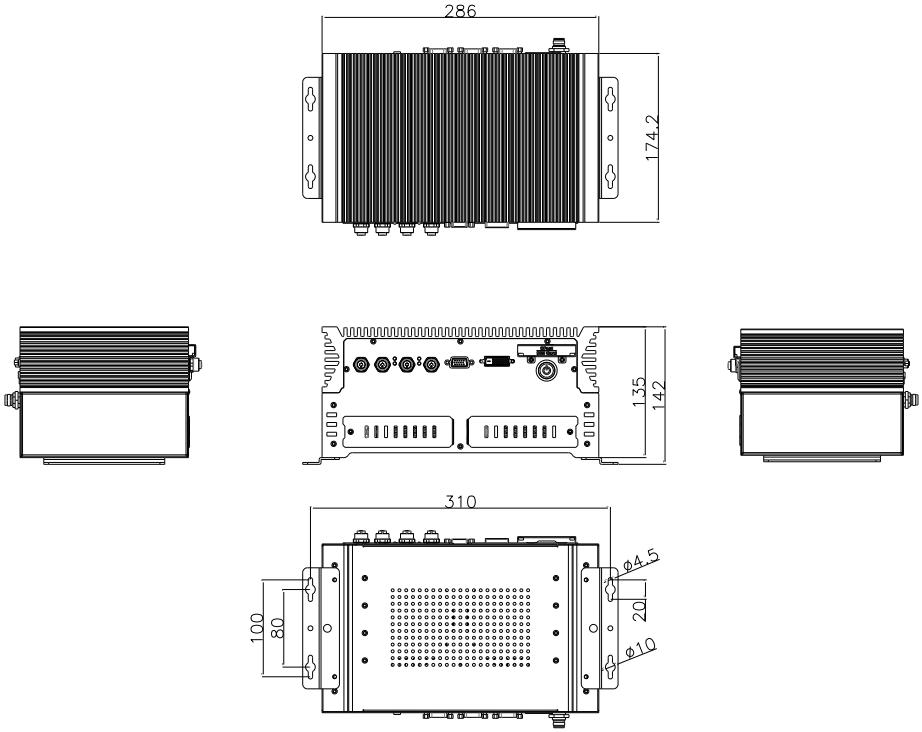

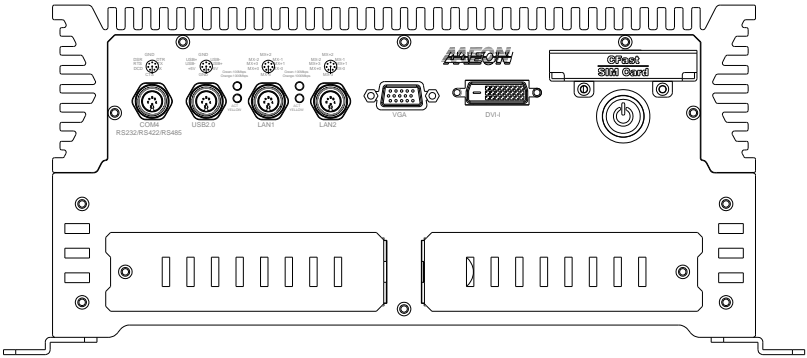
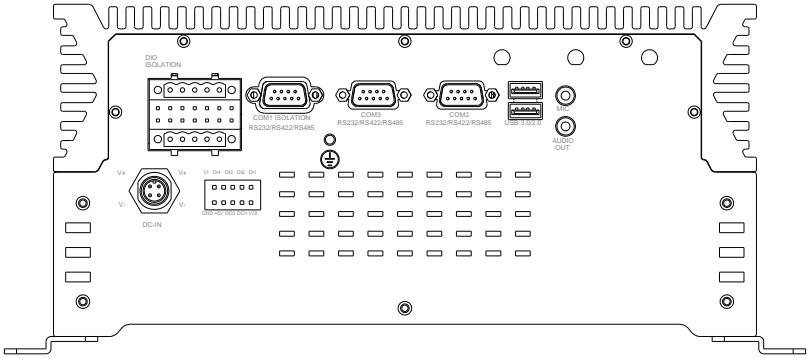

## 2.2 List of Jumpers

---

Please refer to the table below for all of the system's jumpers that you can configure for your application

Label	Function
JP1	Clear CMOS Selection
JP2	Dry and Wet Contact Digital Output Power Selection
JP3	Dry and Wet Contact Digital Input Power Selection
JP4	COM2 12V/5V/RI Selection
JP5	COM3 12V/5V/RI Selection
JP6	AT/ATX Mode Selection

### 2.2.1 Clear CMOS Selection (JP1)

---

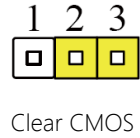
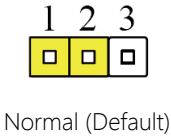

### 2.2.2 Dry and Wet Contact Digital Output Power Selection (JP2)

---

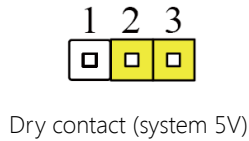
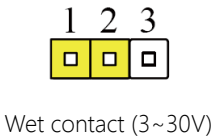

### 2.2.3 Dry and Wet Contact Digital Input Power Selection (JP3)

---

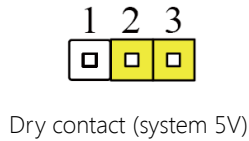
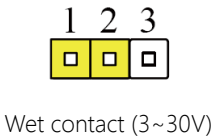

### 2.2.4 COM2/3 12V/5V/RI (JP4/5)

---

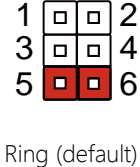
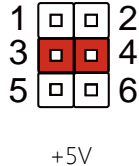
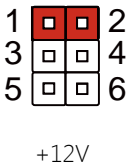

## 2.2.5 AT/ATX Mode Selection (JP6)

---

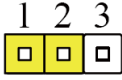

ATX mode

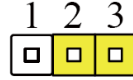

AT mode

## 2.3 List of Connectors

---

Please refer to the table below for all of the system's connectors that you can configure for your application

Label	Function
CN1	M12 Ethernet 1
CN2	M12 Ethernet 2
CN6	Front Panel Connector
CN7	BIOS SPI Flash Header
CN18	LPC Connector
CN22	USB 3.0 Connector
CN23	USB 2.0 Connector
CN34	USB 3.0/2.0 Type A x 2 Connector
CN35	Digital I/O
CN36	Line-out/ Mic-In Audio Connector
CN38	COM2 RS-232/422/485 Connector
CN39	COM3 RS-232/422/485 Connector
CN40	Isolated COM1 RS-232/422/485 Connector
CN41	CFast™ Connector
USBM1	M12 USB 2.0 x 2
PERSONCN1	PERSON Connector
PWESW1	Power Switch
LEDSB5VCN12	Power Standby Connector
LEDCN19	Power LED Connector
HDDLDCN1	Hard Disk LED



### 2.3.1 M12 Ethernet 1/2 (CN1/2)

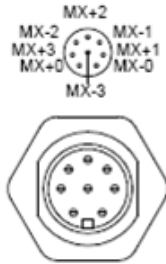

Pin	Signal	Pin	Signal
1	MX-0	2	MX+0
3	MX+3	4	MX-2
5	MX+2	6	MX-1
7	MX+1	8	MX-3

### 2.3.2 Front Panel Connector (CN6)

Pin	Signal	Pin	Signal
1	GND	2	POWER SWITCH
3	HDLED	4	LED POWER
5	NC	6	NC
7	NC	8	NC
9	GND	10	HWRST

### 2.3.3 BIOS SPI Flash Header (CN7)

Pin	Signal	Pin	Signal
1	3.3 V	2	GND
3	CS#	4	CLK

5	SO	6	SI
7	NC	8	NC

### 2.3.4 LCP Connector (CN18)

Pin	Signal	Pin	Signal
1	AD0	2	AD1
3	AD2	4	AD3
5	3.3 V	6	FRAME
7	RST	8	GND
9	CLK	10	DRQ0
11	DRQ1	12	INT

### 2.3.5 USB 3.0 Connector (CN22)

Pin	Signal	Pin	Signal
1	VBUS	2	D+
3	D-	4	GND
5	SSRX-	6	SSRX+
7	GND_DRAIN	8	SSTX-
9	SSTX+	10	SHIELD

### 2.3.6 USB 2.0 Connector (CN23)

Pin	Signal	Pin	Signal
1	5 V	2	D-
3	D+	4	GND

### 2.3.7 Digital Input/ Output (CN35)

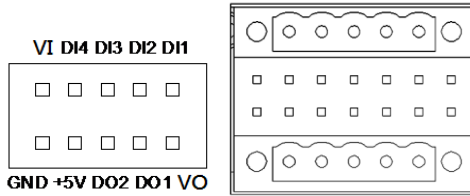

Pin	Signal	Pin	Signal
1	DI1	2	DI2
3	DI3	4	DI4
5	DI_POWER	6	DO_POWER
7	DO1	8	DO2
9	OUTPUT_POWER	10	GND

#### Dry and Wet Contact Digital Input

##### **Digital Input Dry Contact Diagram**

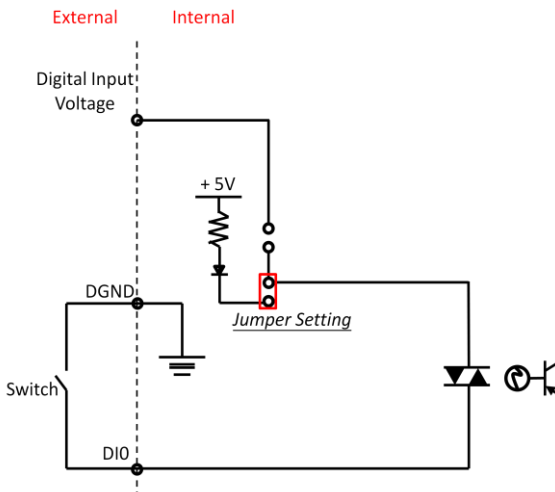

## Digital Input Wet Contact Diagram

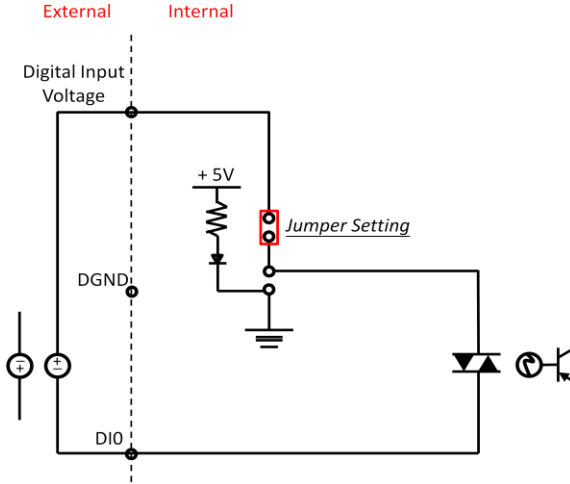

### Dry Contact Wiring

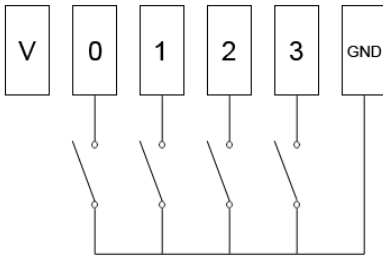

### Wet Contact Wiring

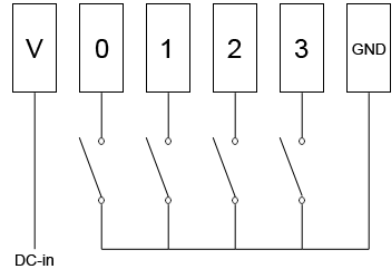

### Digital Input Voltage Range

Max	10 ~ 25V
Min	5V

Pin	Pin Name	Signal Type	Signal Level
1	Digital input 1	Input	DRY (5V) WET (3~30V)
2	Digital input 2	Input	DRY (5V) WET (3~30V)
3	Digital input 3	Input	DRY (5V) WET (3~30V)

4	Digital input 4	Input	DRY (5V) WET (3~30V)
5	WET contact POWER	PWR	3~30V

### Dry and Wet Contact Digital Output

#### Dry Contact Wiring

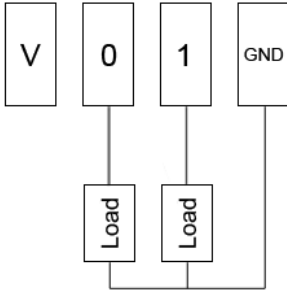

#### Wet Contact Wiring

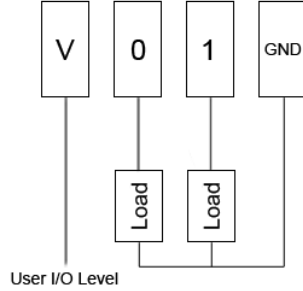

#### Digital Output Voltage Range

Max	30V
Min	5V

Pin	Pin Name	Signal Type	Signal Level
1	Digital Output Power	Input	3 ~ 30 V
2	Digital output 1	Input	Open collector to 30 VDC
3	Digital output 2	Input	Open collector to 30 VDC
4	Isolation DI/O Power	Output	5 V
5	Isolation GND	GND	

### 2.3.8 COM2/3 RS-232/422/485 Connector (CN38/39)

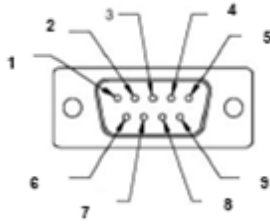

Pin	Signal	Pin	Signal
1	DCD (422TXD-/ 485DATA+)	2	RXD (422RXD+)
3	TXD (422TXD+/ 485DATA+)	4	DTR (422RXD-)
5	GND	6	DSR
7	RTS	8	CTS
9	RI		

### 2.3.9 Isolated COM1 RS-232/422/485 Connector (CN40)

Pin	Signal	Pin	Signal
1	DCD (422TXD-/ 485DATA-)	2	RXD (422RXD+)
3	TXD (422TXD+/ 485DATA+)	4	DTR (422RXD-)
5	GND	6	DSR
7	RTS	8	CTS
9	RI		

### 2.3.10 M12 USB 2.0 x 2 (USBM1)

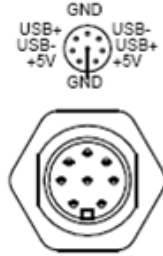

Pin	Signal	Pin	Signal
1	5 V	2	5 V
3	USB1-	4	USB1+
5	GND	6	USB2-
7	USB2+	8	GND

### 2.3.11 PSON Connector (PSONCN1)

Pin	Signal	Pin	Signal
1	PSON#	2	GND

### 2.3.12 Power Switch (PWESW1)

Pin	Signal	Pin	Signal
1	POWER SWITCH	2	GND

### 2.3.13 Power Standby Connector (LEDSB5VCN12)

Pin	Signal	Pin	Signal
1	NC	2	GND

3 LED+/ 5V\_DUAL

---

### 2.3.14 Power LED Connector (LEDCN19)

---

Pin	Signal	Pin	Signal
1	LED+/ +5VS	2	GND

---

### 2.3.15 MiniCard Slot (Full-MiniCard) (CN17)

---

Pin	Signal	Pin	Signal
1	+5VS	2	HDD_SWAPLED-

---



# Chapter 3

---

AMI BIOS Setup

## 3.1 System Test and Initialization

---

The system uses certain routines to perform testing and initialization. If an error, fatal or non-fatal, is encountered, a few short beeps or an error message will be outputted. The board can usually continue the boot up sequence with non-fatal errors.

The system configuration verification routines check the current system configuration against the values stored in the CMOS memory. If they do not match, an error message will be outputted, in which case you will need to run the BIOS setup program to set the configuration information in memory.

There are three situations in which you will need to change the CMOS settings:

- You are starting your system for the first time
- You have changed your system's hardware
- The CMOS memory has lost power and the configuration information is erased

The system's CMOS memory uses a backup battery for data retention, which is to be replaced once emptied.

## 3.2 AMI BIOS Setup

---

The AMI BIOS ROM has a pre-installed Setup program that allows users to modify basic system configurations, which is stored in the battery-backed CMOS RAM and BIOS NVRAM so that the information is retained when the power is turned off.

To enter BIOS Setup, press <Del> or <F2> immediately while your computer is powering up.

The function for each interface can be found below.

**Main** – Date and time can be set here. Press <Tab> to switch between date elements

**Advanced** – Enable/ Disable boot option for legacy network devices

**Chipset** – For hosting bridge parameters

**Boot** – Enable/ Disable quiet Boot Option

**Security** – The setup administrator password can be set here

**Save & Exit** – Save your changes and exit the program

### 3.3 Setup Submenu: Main

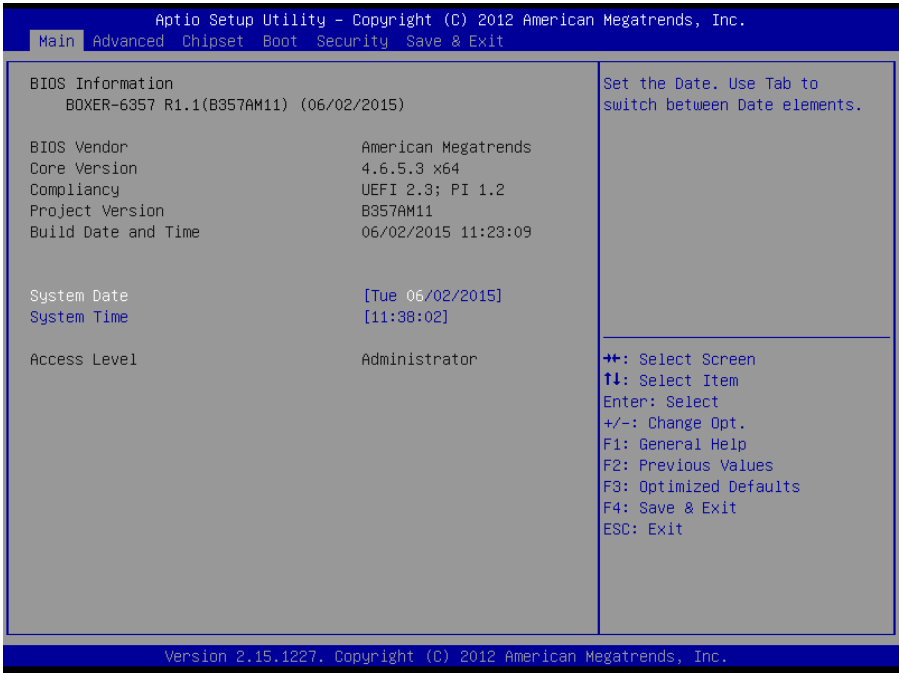

### 3.4 Setup Submenu: Advanced

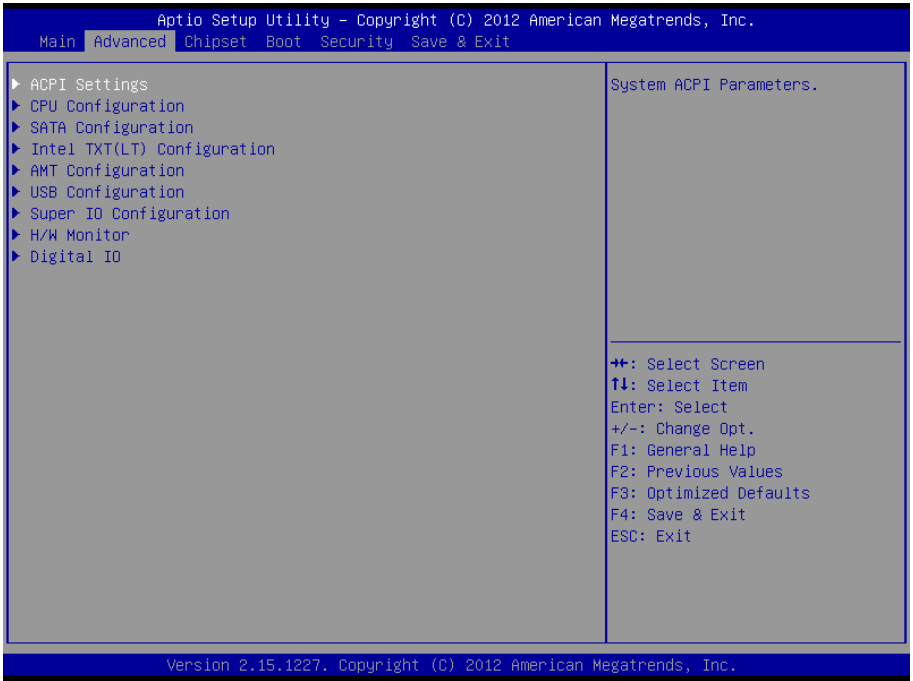

### 3.4.2 Advanced: SATA Configuration

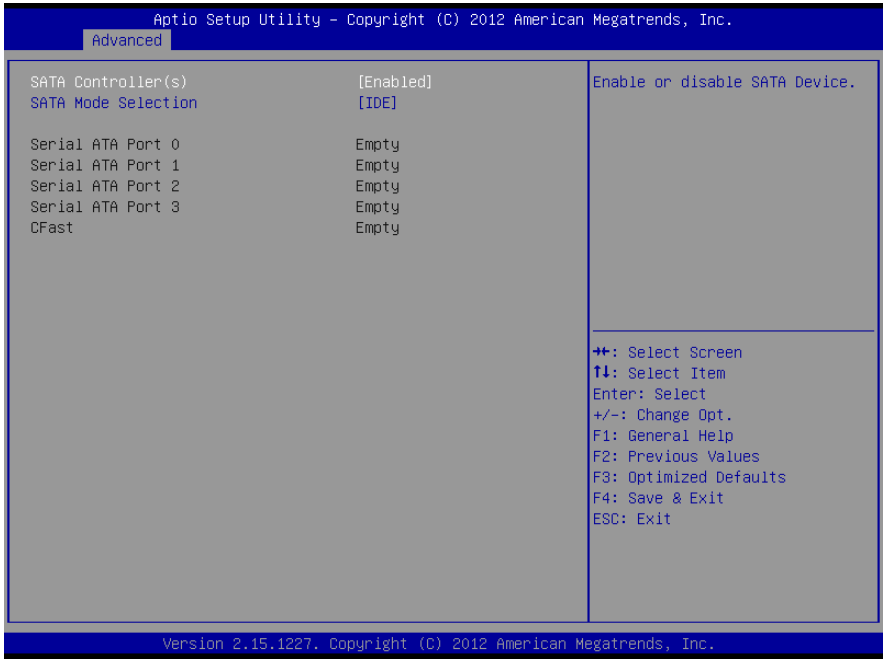

Options summary:

SATA Controllers	Enable	Optimal Default, Failsafe Default
	Disable	
En/Disable SATA Controller		
SATA Mode Selection	IDE	Optimal Default, Failsafe Default
	AHCI	
Determines how SATA controller(s) operate		

### 3.4.3 Advanced: USB Configuration

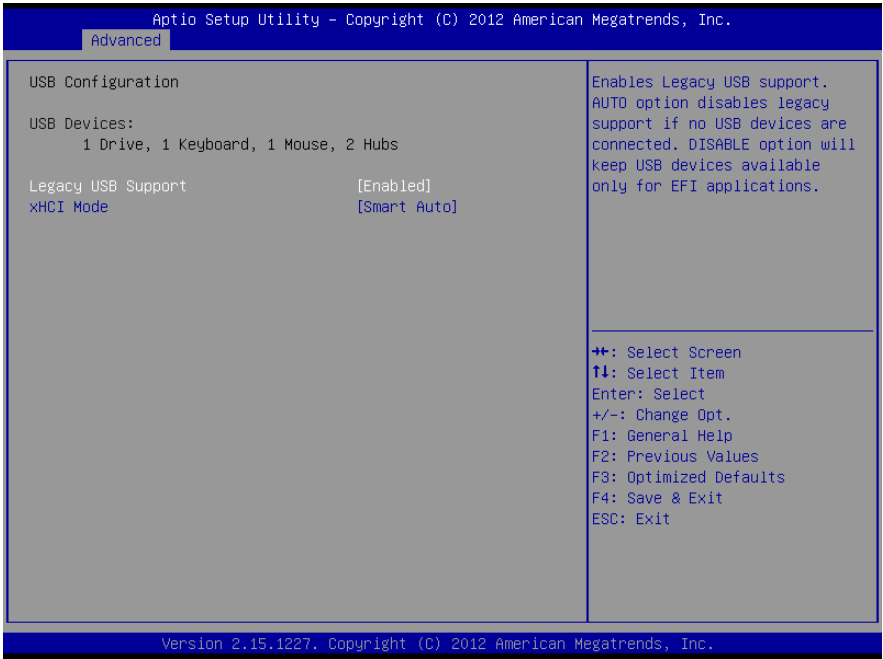

Options summary:

Legacy USB Support	Enable	Optimal Default, Failsafe Default
	Disable	
Enables Legacy USB support. AUTO option disables legacy support if no USB devices are connected. DISABLE option will keep USB devices available only for EFI applications.		
xHCI Mode	Smart Auto	Optimal Default, Failsafe Default
	Auto	
	Enabled	
	Disable	
Mode of operation of xHCI controller		

### 3.4.4 Advanced: Hardware Monitor

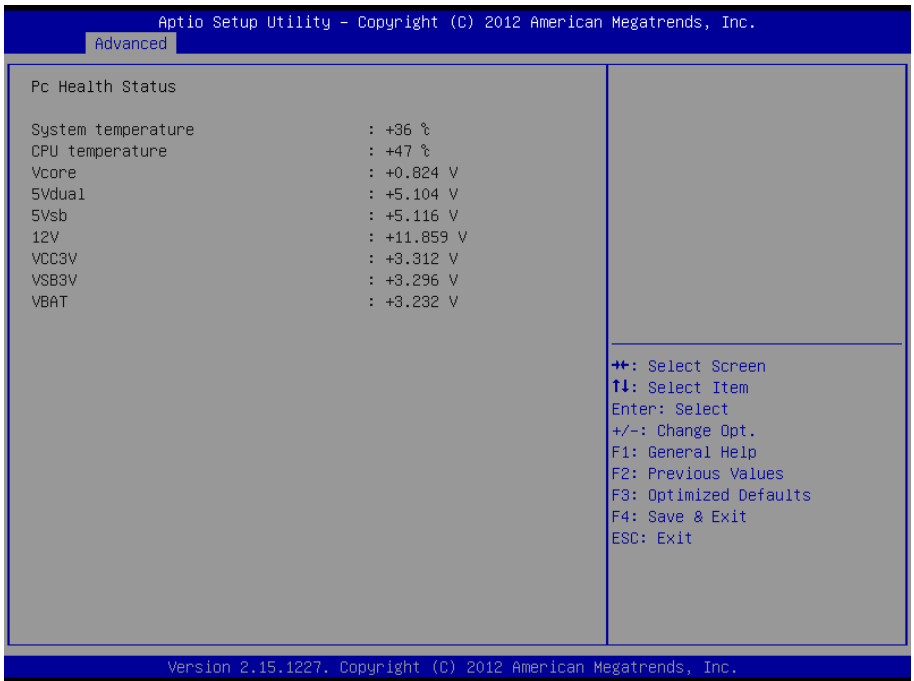



### 3.4.5 Advanced: Dynamic Digital IO Configuration

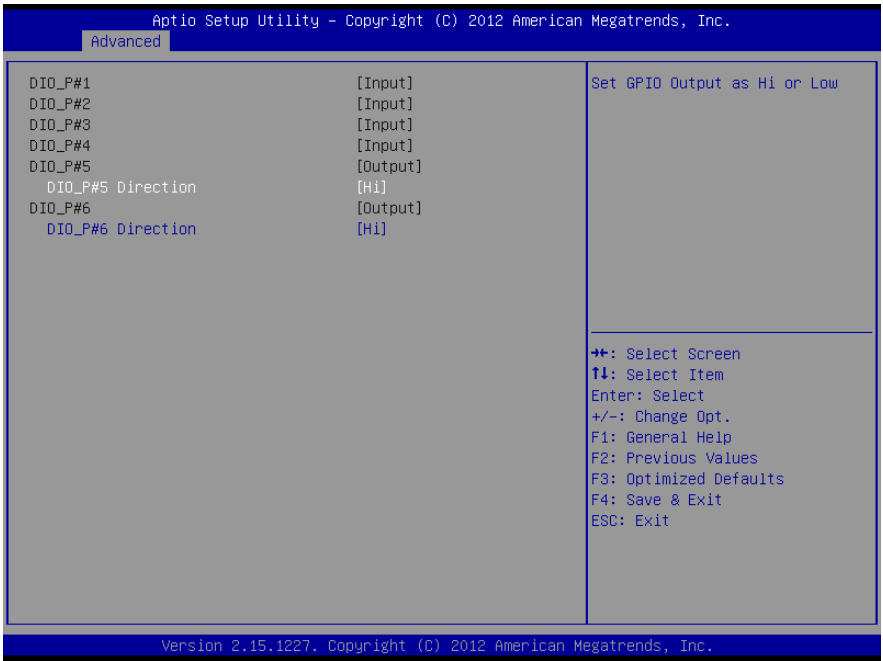

Options summary:

DIO_P#5 Direction[Output]	Low	
Output Level	Hi	Optimal Default, Failsafe Default
Set DIO_P#5 output as Hi or Low		
DIO_P#6 Direction[Output]	Low	
Output Level	Hi	Optimal Default, Failsafe Default
Set DIO_P#6 output as Hi or Low		

### 3.4.6 Advanced: AMT Configuration

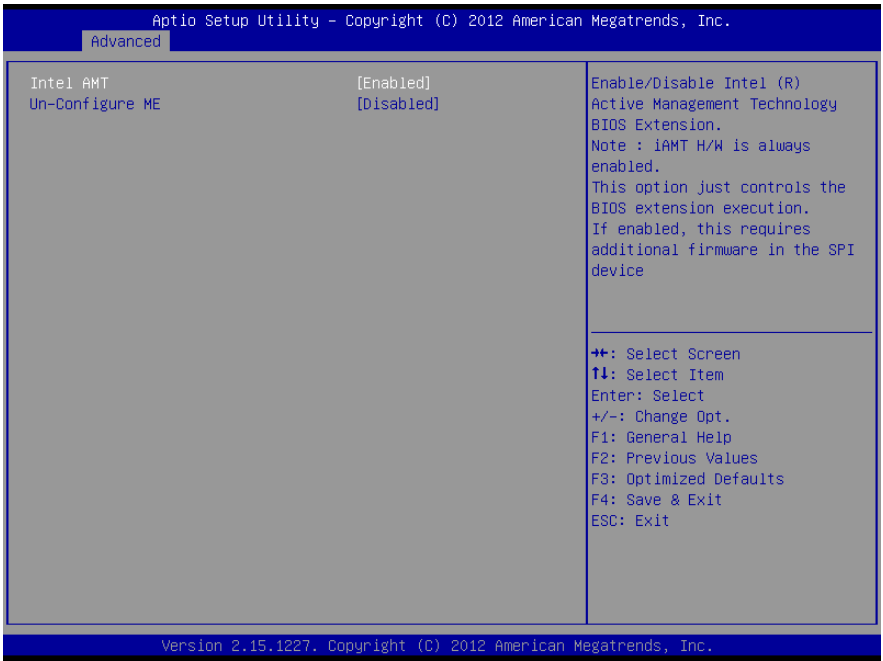

Options summary:

Intel AMT	Disabled	Optimal Default, Failsafe Default
	Enabled	
Enable/Disable Intel (R) Active Management Technology BIOS Extension. Note : iAMT H/W is always enabled. This option controls the BIOS extension execution only. If enabled, additional firmware in the SPI device is required		
Un-Configure ME	Disabled	Optimal Default, Failsafe Default
	Enabled	
OEMFlag Bit 15: Un-Configure ME without password.		

### 3.4.7 Advanced: Super IO Configuration

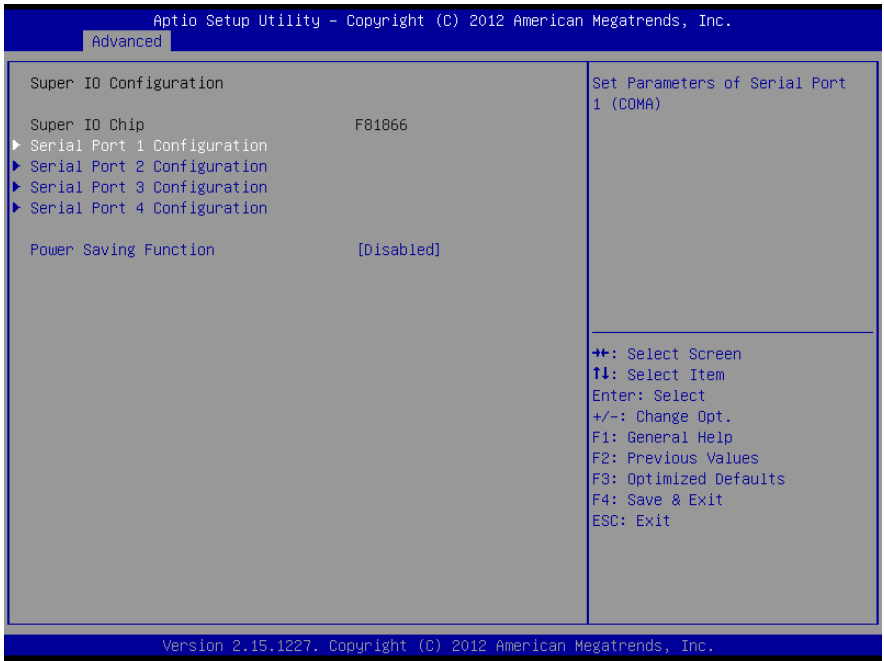

### 3.4.7.1 Super IO Configuration: Serial Port 1 Configuration

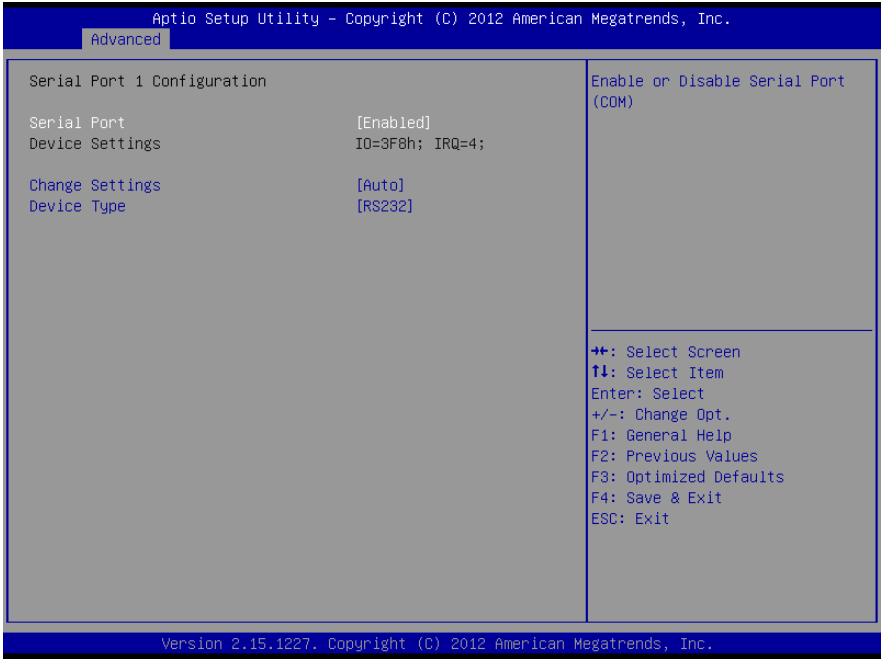

Options summary:

Serial Port	Disabled	Optimal Default, Failsafe Default
	Enabled	
Enable or disable serial port (COM)		
Change Settings	Auto	Optimal Default, Failsafe Default
	IO=3F5h; IRQ=4	
	IO=3F8h; IRQ=3,4	
	IO=2F8h; IRQ=3,4	
	IO=3E8h; IRQ=3,4	
IO=2E8h; IRQ=3,4		
Select an optimal setting for Super IO device		
Device Type	RS232	Optimal Default, Failsafe Default
	RS422	
	RS485	
Select RS-232, RS-422, or RS-485		

### 3.4.7.2 Super IO Configuration: Serial Port 2 Configuration

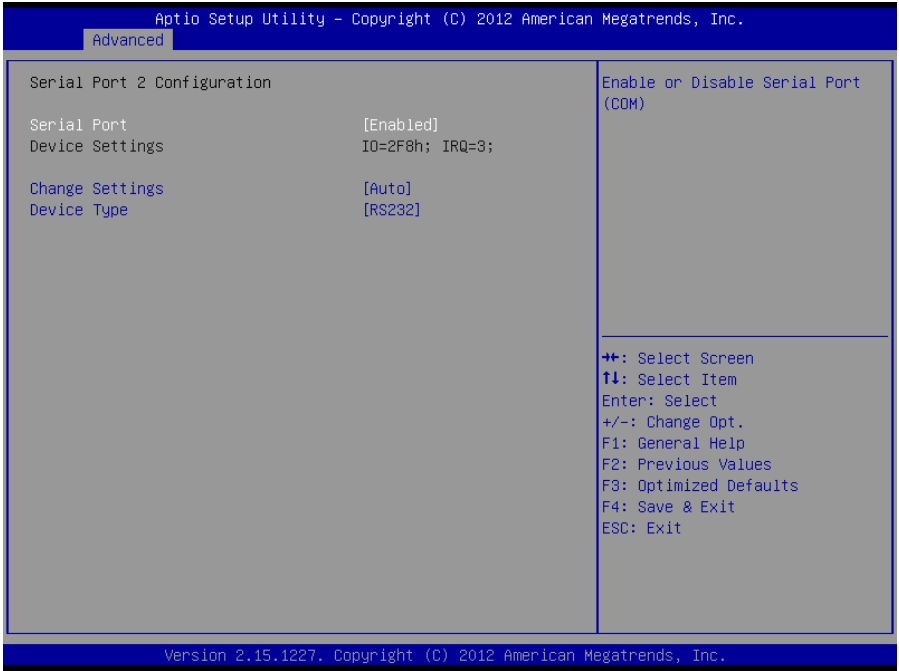

Options summary:

Serial Port	Disabled	Optimal Default, Failsafe Default
	Enabled	
Enable or disable serial port (COM)		
Change Settings	Auto	Optimal Default, Failsafe Default
	IO=2F8h; IRQ=3	
	IO=3F8h; IRQ=3,4	
	IO=2F8h; IRQ=3,4	
	IO=3E8h; IRQ=3,4	
Select an optimal setting for Super IO device		
Device Type	RS232	Optimal Default, Failsafe Default
	RS422	
	RS485	
Select RS-232, RS-422, or RS-485		

### 3.4.7.3 Super IO Configuration: Serial Port 3 Configuration

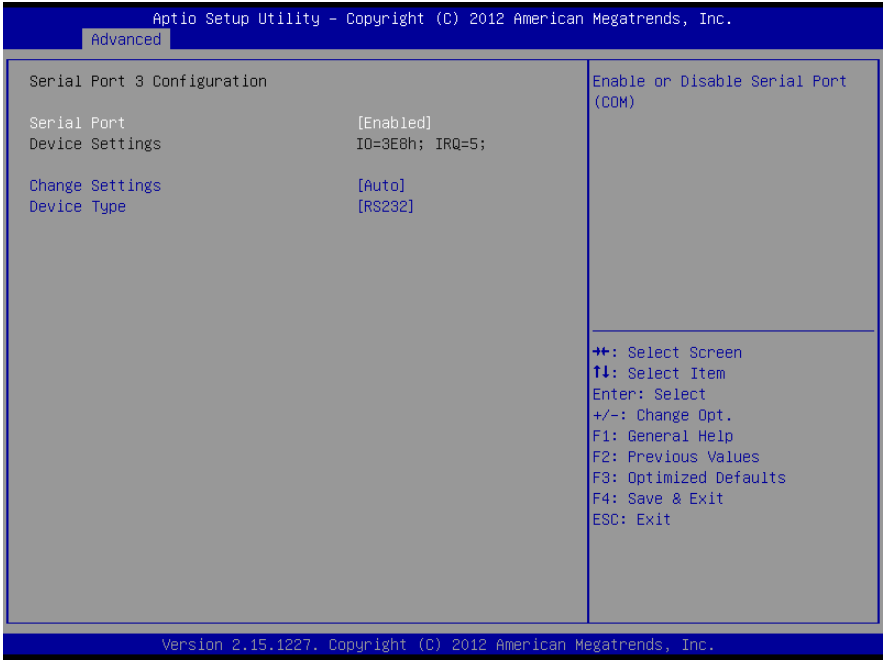

Options summary:

Serial Port	Disabled	Optimal Default, Failsafe Default
	Enabled	
Enable or disable serial port (COM)		
Change Settings	Auto	Optimal Default, Failsafe Default
	IO=3F8h; IRQ=5	
	IO=2E8h; IRQ=5	
	IO=2D0h; IRQ=5	
	IO=2D8h; IRQ=5	
Select an optimal setting for Super IO device		
Device Type	RS232	Optimal Default, Failsafe Default
	RS422	
	RS485	
Select RS-232, RS-422, or RS-485		

### 3.4.7.4 Super IO Configuration: Serial Port 4 Configuration

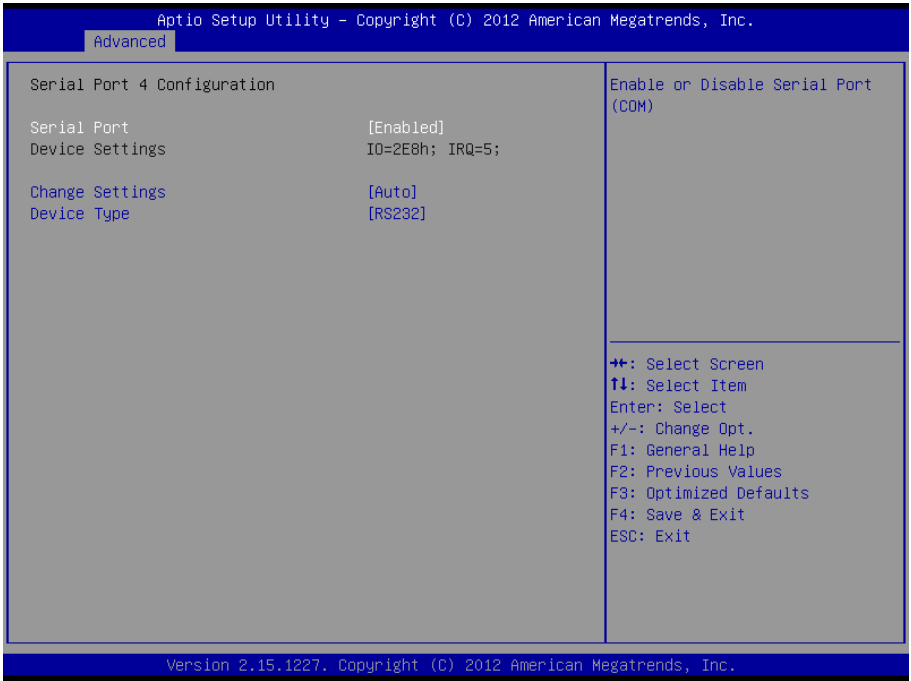

Options summary:

Serial Port	Disabled	Optimal Default, Failsafe Default
	Enabled	
Enable or disable serial port (COM)		
Change Settings	Auto	Optimal Default, Failsafe Default
	IO=2E8h; IRQ=5	
	IO=2E8h; IRQ=5	
	IO=2D0h; IRQ=5	
Select an optimal setting for Super IO device		
Device Type	RS232	Optimal Default, Failsafe Default
	RS422	
	RS485	
Select RS-232, RS-422, or RS-485		

### 3.4.7.5 Super IO Configuration: Power Saving Function

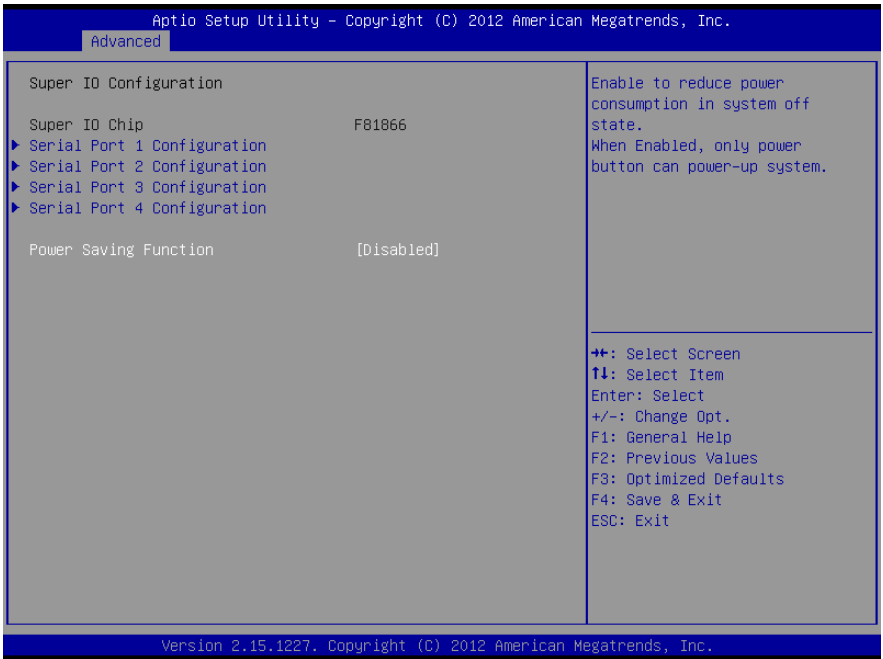

Options summary:

Power Saving Function	Disabled	Optimal Default, Failsafe Default
	Enabled	
Enable to reduce power consumption in system off state When Enabled, only the power button can activate the system.		



### 3.5 Setup submenu: Chipset

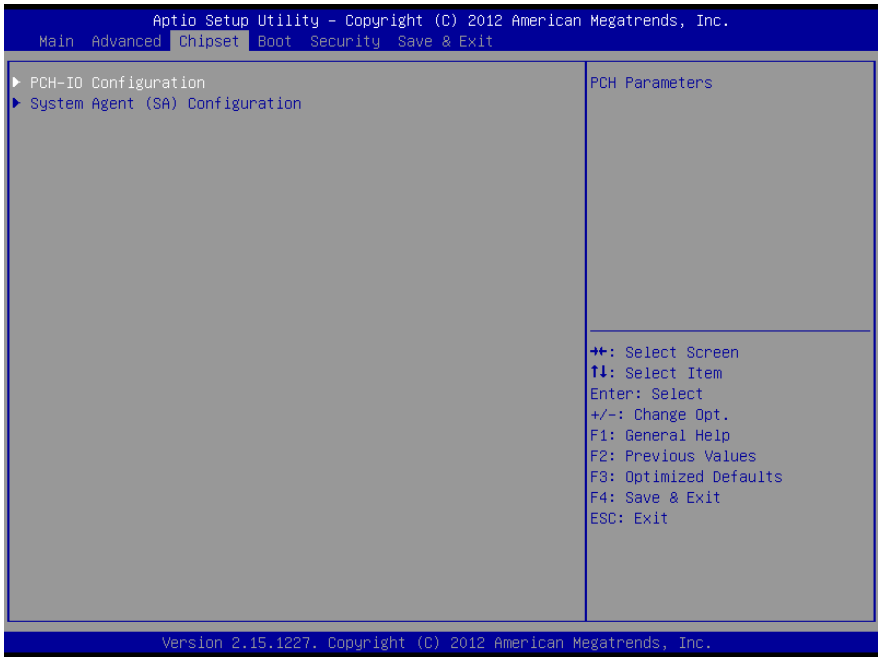

### 3.5.1 Chipset: PCH-IO Configuration

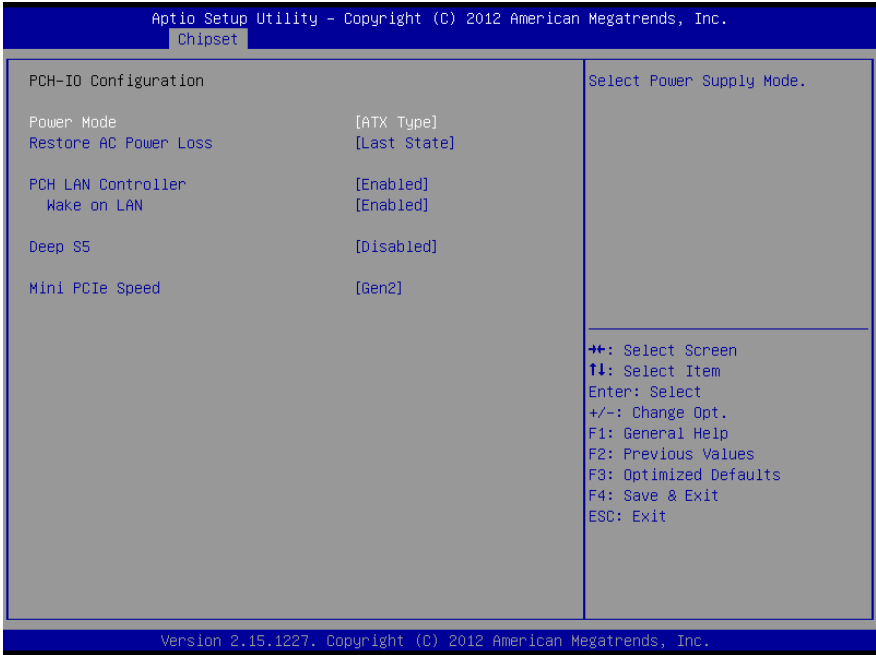

Options summary:

Power Mode	ATX Type	Optimal Default, Failsafe Default
	AT Type	
Select Power Supply Mode		
Restore AC power Loss	Power Off	Optimal Default, Failsafe Default
	Power On	
	Last State	
Select AC power state when power is re-applied after a power failure		
PCH LAN Controller	Enabled	Optimal Default, Failsafe Default
	Disabled	
Enable or disable onboard NIC		
Wake on LAN	Enabled	Optimal Default, Failsafe Default
	Disabled	
Enable or disable integrated LAN to wake the system. (The Wake On LAN cannot be disabled if ME is on at Sx state.)		
Deep S5	Disabled	Optimal Default, Failsafe Default
	Enabled	

Enable/disable Deep S5\n\nNote :\n

When Deep S5 is enabled, Intel® AMT and Wake On PCH LAN functions are not available in system shut down.

Mini PCIe Speed	Gen1	Optimal Default, Failsafe Default
	Gen2	
Select Mini PCI Express port speed		

### 3.5.2 Chipset: System Agent (SA) Configuration

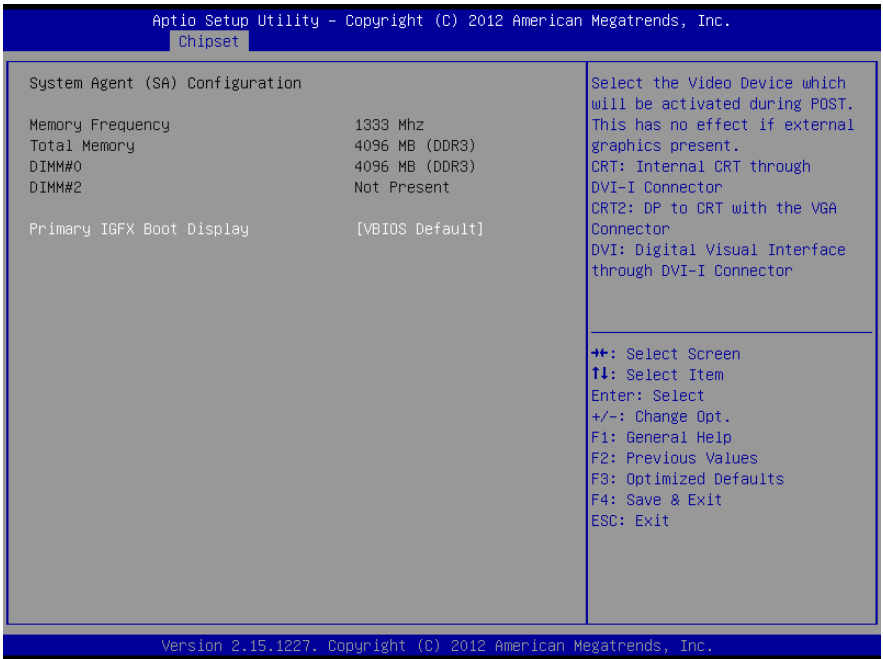

Options summary:

Primary IGFX Boot Display	VBIOS Default	Optimal Default, Failsafe Default
	CRT	
	CRT2	
	DVI	

### 3.6 Setup submenu: Boot

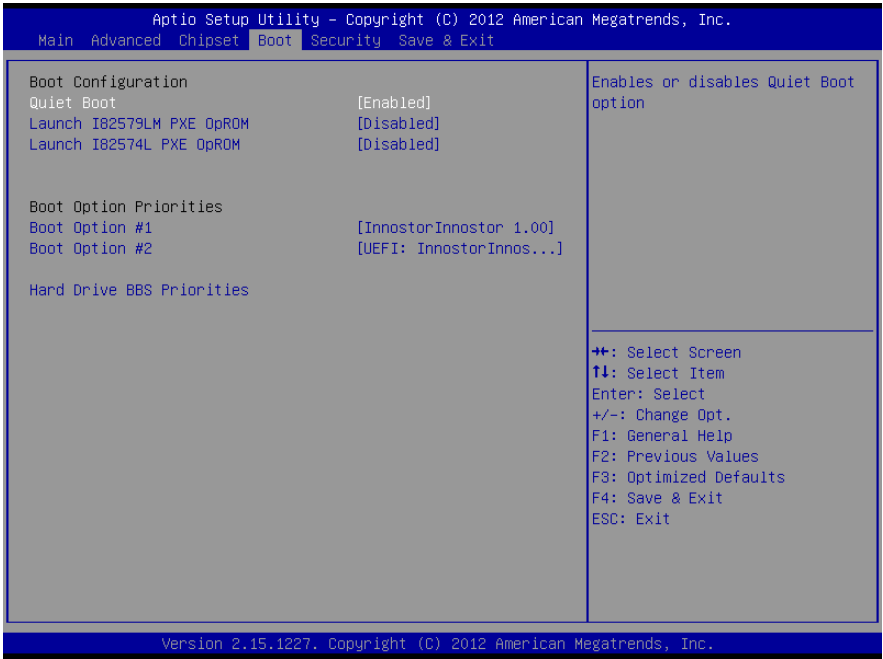

Options summary:

Quiet Boot	Disabled	Default
	Enabled	
Launch I82579LM PXE OpROM	Disabled	Default
	Enabled	
Launch I82574L PXE OpROM	Disabled	Default
	Enabled	

## 3.7 Setup submenu: Security

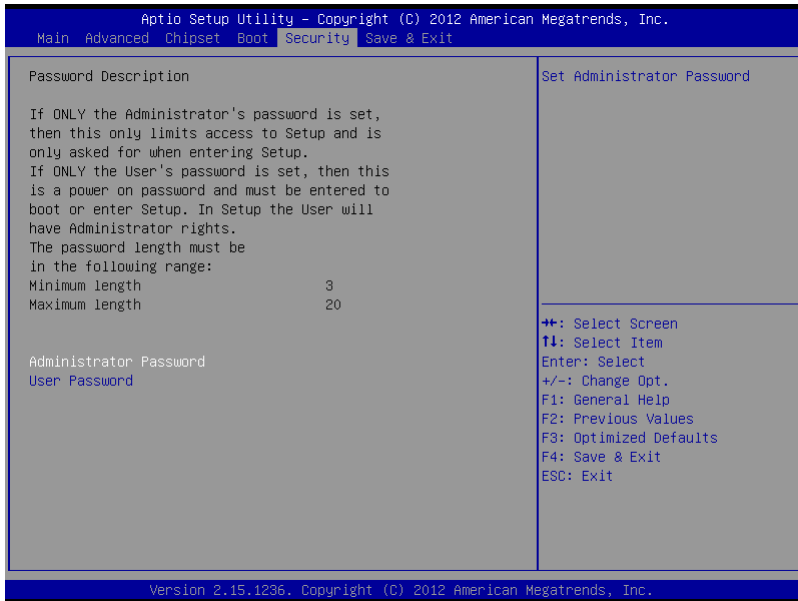

### Change User/Administrator Password

You can set a User Password once an Administrator Password. The password will be required during boot up, or when the user enters the Setup utility. Please Note that a User Password does not provide access to many of the features in the Setup utility.

Select the password you wish to set, press Enter to open a dialog box to enter your password (you can enter no more than six letters or numbers). Press Enter to confirm your entry, after which you will be prompted to retype your password for a final confirmation. Press Enter again after you have retyped it correctly.

### Removing the Password

Highlight this item and type in the current password. At the next dialog box press Enter to disable password protection.

### 3.8 Setup submenu: Save & Exit

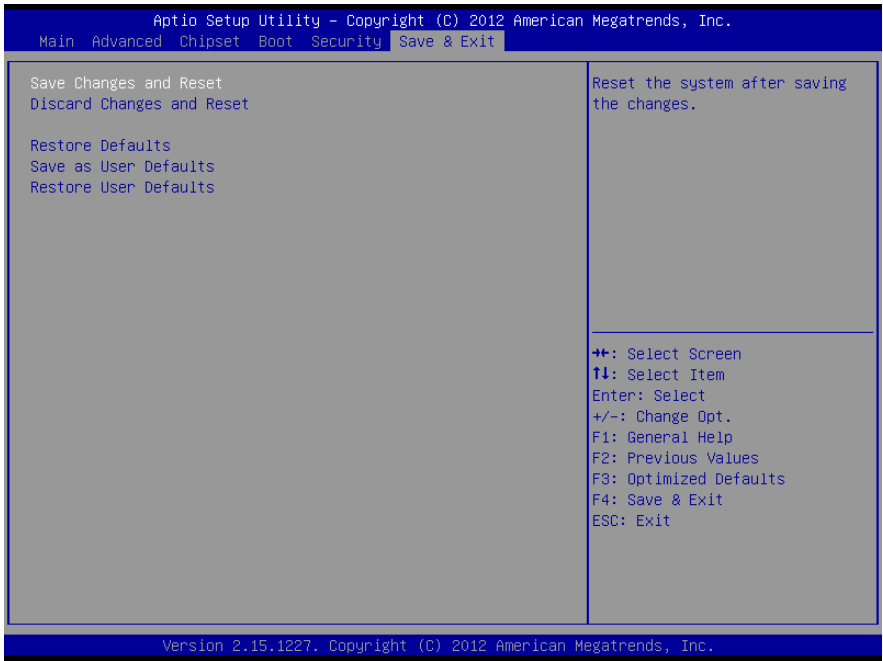

# Chapter 4

---

Drivers Installation



## 4.1 Product CD/DVD

---

The BOXER-6357VS comes with a product DVD that contains all the drivers and utilities you need to setup your product. Insert the DVD and follow the steps in the autorun program to install the drivers.

In case the program does not start, follow the sequence below to install the drivers.

### Step 1 – Install Chipset Driver

1. Open the **Step 1 - Chipset** folder and select your OS
2. Open the **.exe** file in the folder
3. Follow the instructions
4. Drivers will be installed automatically

### Step 2 – Install VGA Driver

1. Open the **Step 2 - VGA** folder and select your OS
2. Open the **.exe** file in the folder
3. Follow the instructions
4. Drivers will be installed automatically

### Step 3 – Install LAN Driver

1. Open the **Step 3 - LAN** folder and select your OS
2. Open the **.exe** file in the folder
3. Follow the instructions
4. Drivers will be installed automatically

### Step 4 – Install Audio Driver

1. Open the **Step 4 - AUDIO** folder and select your OS
2. Open the **.exe** file in the folder
3. Follow the instructions
4. Drivers will be installed automatically

### Step 5 – Install USB 3.0 Driver (Windows 7 only)

1. Open the **Step 5 – USB3.0** folder followed by **setup.exe**
2. Follow the instructions
3. Drivers will be installed automatically

### Step 6 – Install RAID and AHCI Driver

#### For Windows 8.1

1. Open the **STEP 6 – RAID&AHCI** folder and select the **win7\_win8.1** folder
2. Open **SetupRST.exe**
3. Follow the instructions
4. Drivers will be installed automatically

#### For Windows 7

1. Open and install **NDP452-KB2901907-x86-x64-AllOS-ENU.exe**
2. Open the **STEP 6 – RAID&AHCI** folder and select the **win7\_win8.1** folder
3. Open **SetupRST.exe**
4. Follow the instructions
5. Drivers will be installed automatically

#### For Windows XP

Please refer to the **Appendix C RAID & AHCI Settings**

### Step 7 – Install ME Driver

1. Open the **Step 7 – ME** folder
2. Open **setup.exe**
3. Follow the instructions
4. Drivers will be installed automatically

## Step 8 – Install Serial Port Driver (Optional)

### For Windows XP

1. Open the **Step 8 – Serial Port Driver (Optional)** folder and select the **WinXP\_32** folder
2. Open **patch.bat**
3. Follow the instructions
4. Drivers will be installed automatically

## For Windows 7:

### 1. Change User Account Control settings to **Never notify**

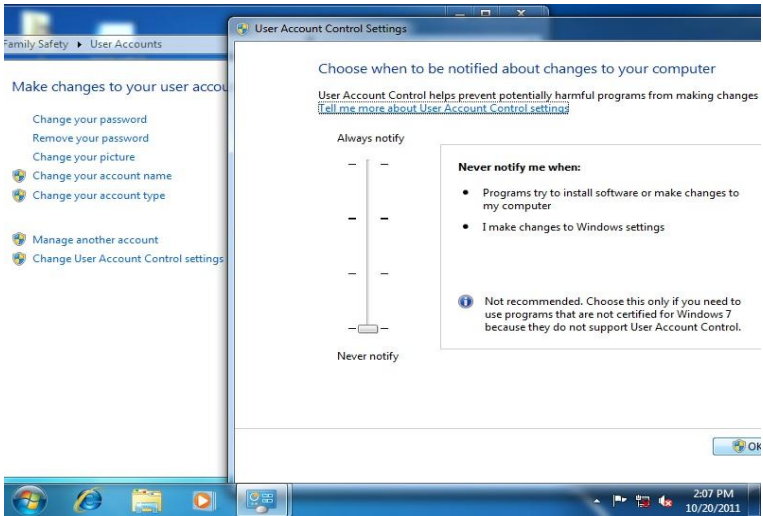

2. Reboot and log in as administrator

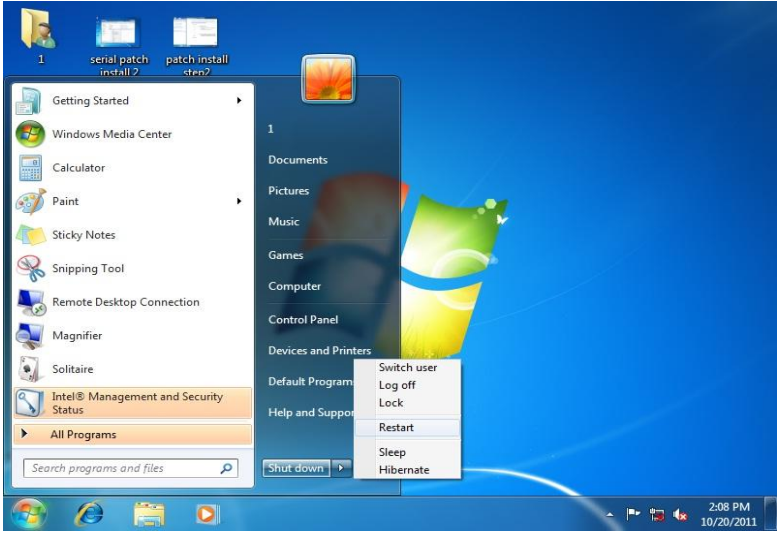

3. Run patch.bat as administrator

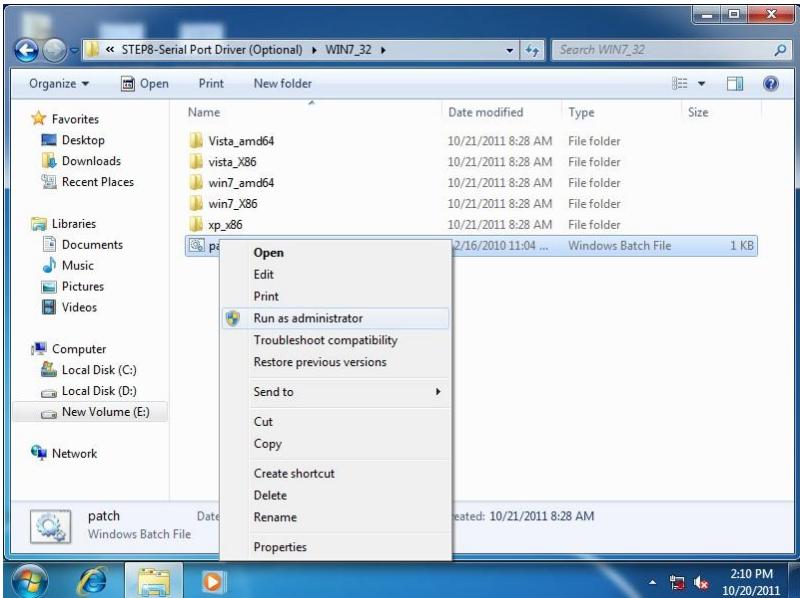

## For Windows 8:

1. Open the Apps Screen, right click on the **Command Prompt** tile and select **Run as Administrator**

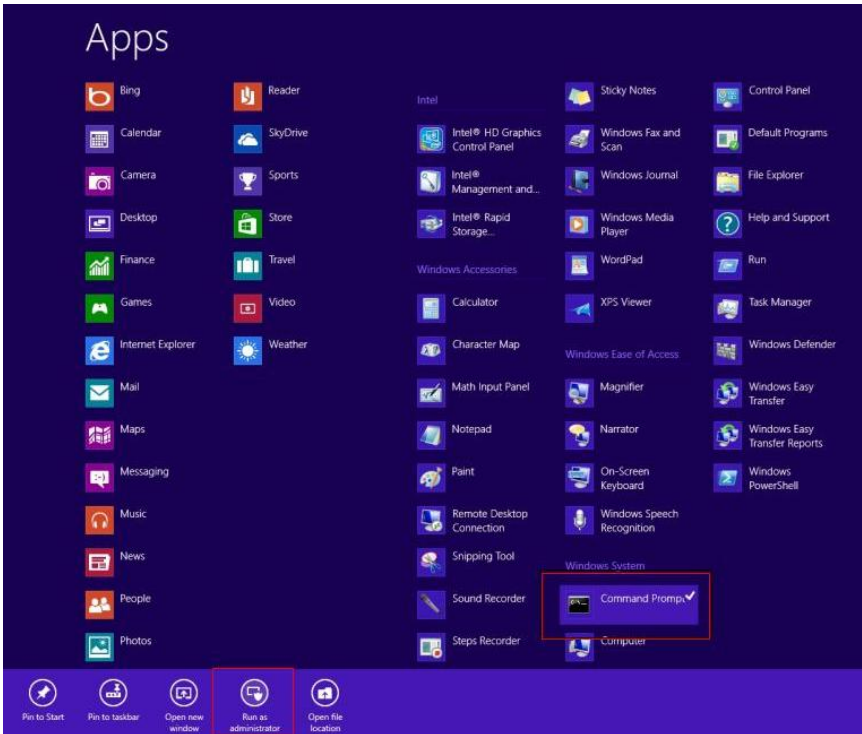

2. To install the driver (patch.bat), you will first have to locate the file in command prompt. To do that, go to the folder in which the file resides by entering **cd (file path)** eg: if the file is in a folder named abc in c drive, enter `cd c:\abc` (screenshot for reference only)
3. You are now at the folder where the file is located. Enter the **patch.bat** to open and install the drivers.

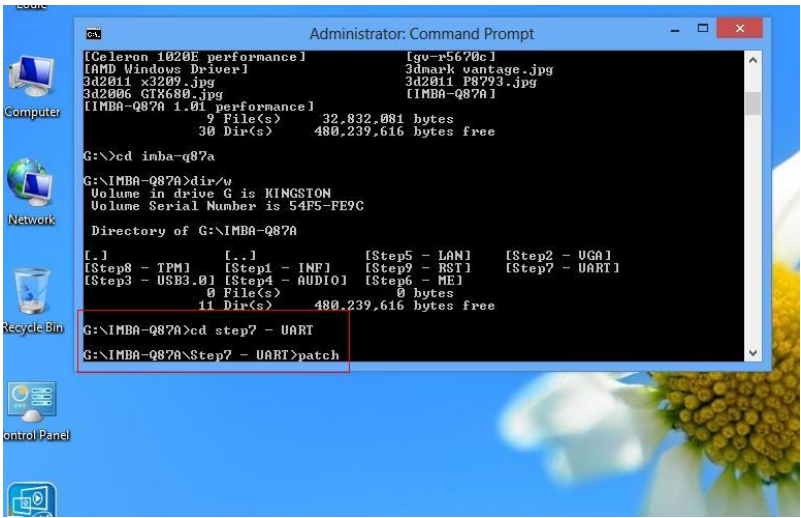

4. Reboot after installation completes.
5. To confirm the installation, go to Device Manager, expand the Ports (COM & LPT) tree and double click on any of the COM ports to open its properties. Go to the Driver tab, select Driver Details and click on **serial.sys**, you should see its provider as **Windows (R) Win 7 DDK Provider**.

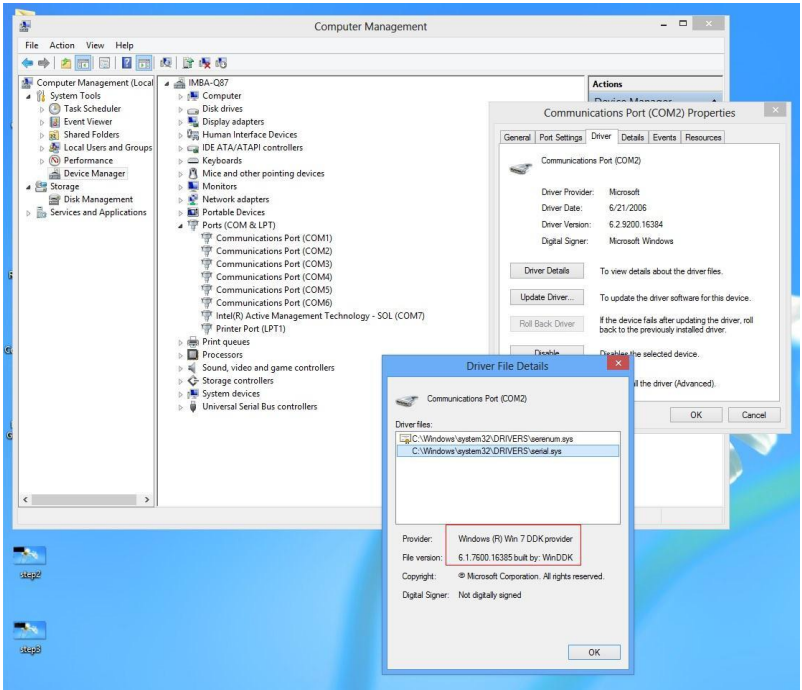



# Appendix A

---

## Watchdog Timer Programming

## A.1 Watchdog Timer Initial Program

Table 1 : SuperIO relative register table		
	Default Value	Note
Index	0x2E(Note1)	SIO MB PnP Mode Index Register 0x2E or 0x4E
Data	0x2F(Note2)	SIO MB PnP Mode Data Register 0x2F or 0x4F

Table 2 : Watchdog relative register table					
	LDN	Register	BitNum	Value	Note
Timer Counter	0x07(Note3)	0xF6(Note4)		(Note24)	Time of watchdog timer (0~255) This register is byte access
Counting Unit	0x07(Note5)	0xF5(Note6)	3(Note7)	0(Note8)	Select time unit. 0: second 1: minute
Watchdog Enable	0x07(Note9)	0xF5(Note10)	5(Note11)	1(Note12)	0: Disable 1: Enable
Timeout Status	0x07(Note13)	0xF5(Note14)	6(Note15)	1	1: Clear timeout status
Output Mode	0x07(Note16)	0xF5(Note17)	4(Note18)	1(Note19)	Select WDTRST# output mode 0: level 1: pulse
WDTRST output	0x07(Note20)	0xFA(Note21)	0(Note22)	1(Note23)	Enable/Disable time out output via WDTRST# 0: Disable 1: Enable

```

*****
// SuperIO relative definition (Please reference to Table 1)
#define byte   SIOIndex //This parameter is represented from Note1
#define byte   SIOData //This parameter is represented from Note2
#define void   IOWriteByte(byte IOPort, byte Value);
#define byte   IOReadByte(byte IOPort);
// Watch Dog relative definition (Please reference to Table 2)
#define byte   TimerLDN //This parameter is represented from Note3
#define byte   TimerReg //This parameter is represented from Note4
#define byte   TimerVal // This parameter is represented from Note24
#define byte   UnitLDN //This parameter is represented from Note5
#define byte   UnitReg //This parameter is represented from Note6
#define byte   UnitBit //This parameter is represented from Note7
#define byte   UnitVal //This parameter is represented from Note8
#define byte   EnableLDN //This parameter is represented from Note9
#define byte   EnableReg //This parameter is represented from Note10
#define byte   EnableBit //This parameter is represented from Note11
#define byte   EnableVal //This parameter is represented from Note12
#define byte   StatusLDN // This parameter is represented from Note13
#define byte   StatusReg // This parameter is represented from Note14
#define byte   StatusBit // This parameter is represented from Note15
#define byte   ModeLDN // This parameter is represented from Note16
#define byte   ModeReg // This parameter is represented from Note17
#define byte   ModeBit // This parameter is represented from Note18
#define byte   ModeVal // This parameter is represented from Note19
#define byte   WDTRstLDN // This parameter is represented from Note20
#define byte   WDTRstReg // This parameter is represented from Note21
#define byte   WDTRstBit // This parameter is represented from Note22
#define byte   WDTRstVal // This parameter is represented from Note23
*****

```

```
*****
VOID Main(){
    // Procedure : AaeonWDTConfig
    // (byte)Timer : Time of WDT timer.(0x00~0xFF)
    // (boolean)Unit : Select time unit(0: second, 1: minute).
    AaeonWDTConfig();

    // Procedure : AaeonWDTEnable
    // This procedure will enable the WDT counting.
    AaeonWDTEnable();
}
*****
```

```

*****
// Procedure : AaeonWDTEnable
VOID  AaeonWDTEnable (){
    WDTEnableDisable(EnableLDN, EnableReg, EnableBit, 1);
}

// Procedure : AaeonWDTConfig
VOID  AaeonWDTConfig (){
    // Disable WDT counting
    WDTEnableDisable(EnableLDN, EnableReg, EnableBit, 0);
    // Clear Watchdog Timeout Status
    WDTClearTimeoutStatus();
    // WDT relative parameter setting
    WDTParameterSetting();
}

VOID  WDTEnableDisable(byte LDN, byte Register, byte BitNum, byte Value){
    SIOBitSet(LDN, Register, BitNum, Value);
}

VOID  WDTParameterSetting(){
    // Watchdog Timer counter setting
    SIOByteSet(TimerLDN, TimerReg, TimerVal);
    // WDT counting unit setting
    SIOBitSet(UnitLDN, UnitReg, UnitBit, UnitVal);
    // WDT output mode setting, level / pulse
    SIOBitSet(ModelLDN, ModeReg, ModeBit, ModeVal);
    // Watchdog timeout output via WDTRST#
    SIOBitSet(WDTRstLDN, WDTRstReg, WDTRstBit, WDTRstVal);
}

VOID  WDTClearTimeoutStatus(){
    SIOBitSet(StatusLDN, StatusReg, StatusBit, 1);
}
*****

```

```

*****
VOID  SIOEnterMBPnPMode(){
    IOWriteByte(SIOIndex, 0x87);
    IOWriteByte(SIOIndex, 0x87);
}

VOID  SIOExitMBPnPMode(){
    IOWriteByte(SIOIndex, 0xAA);
}

VOID  SIOSelectLDN(byte LDN){
    IOWriteByte(SIOIndex, 0x07); // SIO LDN Register Offset = 0x07
    IOWriteByte(SIOData, LDN);
}

VOID  SIOBitSet(byte LDN, byte Register, byte BitNum, byte Value){
    Byte TmpValue;

    SIOEnterMBPnPMode();
    SIOSelectLDN(byte LDN);
    IOWriteByte(SIOIndex, Register);
    TmpValue = IOReadByte(SIOData);
    TmpValue &= ~(1 << BitNum);
    TmpValue |= (Value << BitNum);
    IOWriteByte(SIOData, TmpValue);
    SIOExitMBPnPMode();
}

VOID  SIOByteSet(byte LDN, byte Register, byte Value){
    SIOEnterMBPnPMode();
    SIOSelectLDN(LDN);
    IOWriteByte(SIOIndex, Register);
    IOWriteByte(SIOData, Value);
    SIOExitMBPnPMode();
}
*****

```

# Appendix B

---





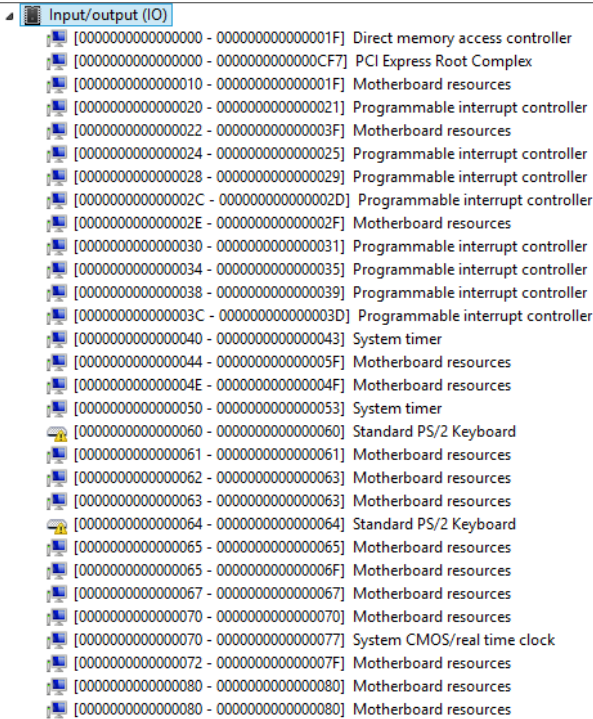

















I/O Information































## B.1 I/O Address Map



Address Range	Description
[0000000000000000 - 000000000000001F]	Direct memory access controller
[0000000000000000 - 0000000000000CF7]	PCI Express Root Complex
[0000000000000010 - 000000000000001F]	Motherboard resources
[0000000000000020 - 0000000000000021]	Programmable interrupt controller
[0000000000000022 - 000000000000003F]	Motherboard resources
[0000000000000024 - 0000000000000025]	Programmable interrupt controller
[0000000000000028 - 0000000000000029]	Programmable interrupt controller
[000000000000002C - 000000000000002D]	Programmable interrupt controller
[000000000000002E - 000000000000002F]	Motherboard resources
[0000000000000030 - 0000000000000031]	Programmable interrupt controller
[0000000000000034 - 0000000000000035]	Programmable interrupt controller
[0000000000000038 - 0000000000000039]	Programmable interrupt controller
[000000000000003C - 000000000000003D]	Programmable interrupt controller
[0000000000000040 - 0000000000000043]	System timer
[0000000000000044 - 000000000000005F]	Motherboard resources
[000000000000004E - 000000000000004F]	Motherboard resources
[0000000000000050 - 0000000000000053]	System timer
[0000000000000060 - 0000000000000060]	Standard PS/2 Keyboard
[0000000000000061 - 0000000000000061]	Motherboard resources
[0000000000000062 - 0000000000000063]	Motherboard resources
[0000000000000063 - 0000000000000063]	Motherboard resources
[0000000000000064 - 0000000000000064]	Standard PS/2 Keyboard
[0000000000000065 - 0000000000000065]	Motherboard resources
[0000000000000065 - 000000000000006F]	Motherboard resources
[0000000000000067 - 0000000000000067]	Motherboard resources
[0000000000000070 - 0000000000000070]	Motherboard resources
[0000000000000070 - 0000000000000077]	System CMOS/real time clock
[0000000000000072 - 000000000000007F]	Motherboard resources
[0000000000000080 - 0000000000000080]	Motherboard resources
[0000000000000080 - 0000000000000080]	Motherboard resources



















































	[0000000000000072 - 000000000000007F]	Motherboard resources
	[0000000000000080 - 0000000000000080]	Motherboard resources
	[0000000000000080 - 0000000000000080]	Motherboard resources
	[0000000000000081 - 0000000000000091]	Direct memory access controller
	[0000000000000084 - 0000000000000086]	Motherboard resources
	[0000000000000088 - 0000000000000088]	Motherboard resources
	[000000000000008C - 000000000000008E]	Motherboard resources
	[0000000000000090 - 000000000000009F]	Motherboard resources
	[0000000000000092 - 0000000000000092]	Motherboard resources
	[0000000000000093 - 000000000000009F]	Direct memory access controller
	[00000000000000A0 - 00000000000000A1]	Programmable interrupt controller
	[00000000000000A2 - 00000000000000BF]	Motherboard resources
	[00000000000000A4 - 00000000000000A5]	Programmable interrupt controller
	[00000000000000A8 - 00000000000000A9]	Programmable interrupt controller
	[00000000000000AC - 00000000000000AD]	Programmable interrupt controller
	[00000000000000B0 - 00000000000000B1]	Programmable interrupt controller
	[00000000000000B2 - 00000000000000B3]	Motherboard resources
	[00000000000000B4 - 00000000000000B5]	Programmable interrupt controller
	[00000000000000B8 - 00000000000000B9]	Programmable interrupt controller
	[00000000000000BC - 00000000000000BD]	Programmable interrupt controller
	[00000000000000C0 - 00000000000000DF]	Direct memory access controller
	[00000000000000E0 - 00000000000000EF]	Motherboard resources
	[00000000000000F0 - 00000000000000FF]	Numeric data processor
	[00000000000002E8 - 00000000000002EF]	Communications Port (COM4)
	[00000000000002F8 - 00000000000002FF]	Communications Port (COM2)
	[00000000000003B0 - 00000000000003BB]	Intel(R) HD Graphics 4000
	[00000000000003C0 - 00000000000003DF]	Intel(R) HD Graphics 4000
	[00000000000003E8 - 00000000000003EF]	Communications Port (COM3)
	[00000000000003F8 - 00000000000003FF]	Communications Port (COM1)
	[0000000000000400 - 0000000000000453]	Motherboard resources
	[0000000000000454 - 0000000000000457]	Motherboard resources

































	[000000000000454 - 000000000000457]	Motherboard resources
	[000000000000458 - 00000000000047F]	Motherboard resources
	[0000000000004D0 - 0000000000004D1]	Motherboard resources
	[0000000000004D0 - 0000000000004D1]	Programmable interrupt controller
	[000000000000500 - 00000000000057F]	Motherboard resources
	[000000000000680 - 00000000000069F]	Motherboard resources
	[000000000000A00 - 000000000000A0F]	Motherboard resources
	[000000000000A10 - 000000000000A1F]	Motherboard resources
	[000000000000A20 - 000000000000A2F]	Motherboard resources
	[000000000000D00 - 000000000000FFFF]	PCI Express Root Complex
	[0000000000001000 - 000000000000100F]	Motherboard resources
	[000000000000164E - 000000000000164F]	Motherboard resources
	[000000000000E000 - 000000000000EFFF]	Intel(R) 7 Series/C216 Chipset Family PCI Express Root Port 2 - 1E12
	[000000000000F000 - 000000000000F03F]	Intel(R) HD Graphics 4000
	[000000000000F040 - 000000000000F05F]	Intel(R) 7 Series/C216 Chipset Family SMBus Host Controller - 1E22
	[000000000000F080 - 000000000000F08F]	Intel(R) 7 Series/C216 Chipset Family 2 port Serial ATA Storage Controller - 1E09
	[000000000000F090 - 000000000000F09F]	Intel(R) 7 Series/C216 Chipset Family 2 port Serial ATA Storage Controller - 1E09
	[000000000000F0A0 - 000000000000F0A3]	Intel(R) 7 Series/C216 Chipset Family 2 port Serial ATA Storage Controller - 1E09
	[000000000000F0B0 - 000000000000F0BF]	Intel(R) 7 Series/C216 Chipset Family 2 port Serial ATA Storage Controller - 1E09
	[000000000000F0C0 - 000000000000F0C3]	Intel(R) 7 Series/C216 Chipset Family 2 port Serial ATA Storage Controller - 1E09
	[000000000000F0D0 - 000000000000F0D7]	Intel(R) 7 Series/C216 Chipset Family 2 port Serial ATA Storage Controller - 1E09
	[000000000000F0E0 - 000000000000F0EF]	Intel(R) 7 Series/C216 Chipset Family 4 port Serial ATA Storage Controller - 1E01
	[000000000000F0F0 - 000000000000F0FF]	Intel(R) 7 Series/C216 Chipset Family 4 port Serial ATA Storage Controller - 1E01
	[000000000000F100 - 000000000000F103]	Intel(R) 7 Series/C216 Chipset Family 4 port Serial ATA Storage Controller - 1E01
	[000000000000F110 - 000000000000F117]	Intel(R) 7 Series/C216 Chipset Family 4 port Serial ATA Storage Controller - 1E01
	[000000000000F120 - 000000000000F123]	Intel(R) 7 Series/C216 Chipset Family 4 port Serial ATA Storage Controller - 1E01
	[000000000000F130 - 000000000000F137]	Intel(R) 7 Series/C216 Chipset Family 4 port Serial ATA Storage Controller - 1E01
	[000000000000F140 - 000000000000F147]	Intel(R) Active Management Technology - SOL (COM5)
	[000000000000FFFF - 000000000000FFFF]	Motherboard resources
	[000000000000FFFF - 000000000000FFFF]	Motherboard resources

































## B.2 Memory Address Map

Memory	
[000000000000A0000 - 00000000000BFFFFF]	Intel(R) HD Graphics 4000
[000000000000A0000 - 00000000000BFFFFF]	PCI Express Root Complex
[000000000000D0000 - 00000000000D3FFF]	PCI Express Root Complex
[000000000000D4000 - 00000000000D7FFF]	PCI Express Root Complex
[000000000000D8000 - 00000000000DBFFF]	PCI Express Root Complex
[000000000000DC000 - 00000000000DFFFF]	PCI Express Root Complex
[000000000000E0000 - 00000000000E3FFF]	PCI Express Root Complex
[000000000000E4000 - 00000000000E7FFF]	PCI Express Root Complex
[0000000020000000 - 00000000201FFFFF]	System board
[0000000040004000 - 0000000040004FFF]	System board
[00000000DFA00000 - 00000000DFA00FFF]	Motherboard resources
[00000000DFA00000 - 00000000FEAFFFFF]	PCI Express Root Complex
[00000000E0000000 - 00000000EFFFFFFF]	Intel(R) HD Graphics 4000
[00000000F7800000 - 00000000F7BFFFFF]	Intel(R) HD Graphics 4000
[00000000F7C00000 - 00000000F7C1FFFF]	Intel(R) 82574L Gigabit Network Connection
[00000000F7C00000 - 00000000F7C7FFFF]	Intel(R) 7 Series/C216 Chipset Family PCI Express Root Port 2 - 1E12
[00000000F7C20000 - 00000000F7C23FFF]	Intel(R) 82574L Gigabit Network Connection
[00000000F7D00000 - 00000000F7D1FFFF]	Intel(R) 82579LM Gigabit Network Connection
[00000000F7D20000 - 00000000F7D2FFFF]	Intel(R) USB 3.0 eXtensible Host Controller - 0100 (Microsoft)
[00000000F7D30000 - 00000000F7D33FFF]	High Definition Audio Controller
[00000000F7D35000 - 00000000F7D350FF]	Intel(R) 7 Series/C216 Chipset Family SMBus Host Controller - 1E22
[00000000F7D36000 - 00000000F7D363FF]	Intel(R) 7 Series/C216 Chipset Family USB Enhanced Host Controller - 1E26
[00000000F7D37000 - 00000000F7D373FF]	Intel(R) 7 Series/C216 Chipset Family USB Enhanced Host Controller - 1E2D
[00000000F7D38000 - 00000000F7D38FFF]	Intel(R) 82579LM Gigabit Network Connection
[00000000F7D39000 - 00000000F7D39FFF]	Intel(R) Active Management Technology - SOL (COM5)
[00000000F7D3B000 - 00000000F7D3B00F]	Intel(R) Management Engine Interface
[00000000F8000000 - 00000000FBFFFFFF]	Motherboard resources
[00000000FED00000 - 00000000FED003FF]	High precision event timer
[00000000FED10000 - 00000000FED17FFF]	Motherboard resources
[00000000FED18000 - 00000000FED18FFF]	Motherboard resources
[00000000FED19000 - 00000000FED19FFF]	Motherboard resources
[00000000FED1C000 - 00000000FED1FFFF]	Motherboard resources
[00000000FED20000 - 00000000FED3FFFF]	Motherboard resources
[00000000FED40000 - 00000000FED44FFF]	System board
[00000000FED45000 - 00000000FED8FFFF]	Motherboard resources
[00000000FED90000 - 00000000FED93FFF]	Motherboard resources
[00000000FEE00000 - 00000000FEEFFFFFFF]	Motherboard resources
[00000000FF000000 - 00000000FFFFFFFF]	Intel(R) 82802 Firmware Hub Device
[00000000FF000000 - 00000000FFFFFFFF]	Motherboard resources

































## B.3 IRQ Mapping Chart

































	<b>Interrupt request (IRQ)</b>	
	(ISA) 0x00000000 (00)	System timer
	(ISA) 0x00000001 (01)	Standard PS/2 Keyboard
	(ISA) 0x00000003 (03)	Communications Port (COM2)
	(ISA) 0x00000004 (04)	Communications Port (COM1)
	(ISA) 0x00000005 (05)	Communications Port (COM3)
	(ISA) 0x00000005 (05)	Communications Port (COM4)
	(ISA) 0x00000008 (08)	System CMOS/real time clock
	(ISA) 0x0000000C (12)	Microsoft PS/2 Mouse
	(ISA) 0x0000000D (13)	Numeric data processor
	(ISA) 0x00000051 (81)	Microsoft ACPI-Compliant System
	(ISA) 0x00000052 (82)	Microsoft ACPI-Compliant System
	(ISA) 0x00000053 (83)	Microsoft ACPI-Compliant System
	(ISA) 0x00000054 (84)	Microsoft ACPI-Compliant System
	(ISA) 0x00000055 (85)	Microsoft ACPI-Compliant System
	(ISA) 0x00000056 (86)	Microsoft ACPI-Compliant System
	(ISA) 0x00000057 (87)	Microsoft ACPI-Compliant System
	(ISA) 0x00000058 (88)	Microsoft ACPI-Compliant System
	(ISA) 0x00000059 (89)	Microsoft ACPI-Compliant System
	(ISA) 0x0000005A (90)	Microsoft ACPI-Compliant System
	(ISA) 0x0000005B (91)	Microsoft ACPI-Compliant System
	(ISA) 0x0000005C (92)	Microsoft ACPI-Compliant System
	(ISA) 0x0000005D (93)	Microsoft ACPI-Compliant System
	(ISA) 0x0000005E (94)	Microsoft ACPI-Compliant System
	(ISA) 0x0000005F (95)	Microsoft ACPI-Compliant System
	(ISA) 0x00000060 (96)	Microsoft ACPI-Compliant System
	(ISA) 0x00000061 (97)	Microsoft ACPI-Compliant System
	(ISA) 0x00000062 (98)	Microsoft ACPI-Compliant System
	(ISA) 0x00000063 (99)	Microsoft ACPI-Compliant System
	(ISA) 0x00000064 (100)	Microsoft ACPI-Compliant System
	(ISA) 0x00000065 (101)	Microsoft ACPI-Compliant System
	(ISA) 0x00000066 (102)	Microsoft ACPI-Compliant System
	(ISA) 0x00000067 (103)	Microsoft ACPI-Compliant System
	(ISA) 0x00000068 (104)	Microsoft ACPI-Compliant System
	(ISA) 0x00000069 (105)	Microsoft ACPI-Compliant System
	(ISA) 0x0000006A (106)	Microsoft ACPI-Compliant System
	(ISA) 0x0000006B (107)	Microsoft ACPI-Compliant System
	(ISA) 0x0000006C (108)	Microsoft ACPI-Compliant System
	(ISA) 0x0000006D (109)	Microsoft ACPI-Compliant System
	(ISA) 0x0000006E (110)	Microsoft ACPI-Compliant System
	(ISA) 0x0000006F (111)	Microsoft ACPI-Compliant System
	(ISA) 0x00000070 (112)	Microsoft ACPI-Compliant System
	(ISA) 0x00000071 (113)	Microsoft ACPI-Compliant System
	(ISA) 0x00000072 (114)	Microsoft ACPI-Compliant System
	(ISA) 0x00000073 (115)	Microsoft ACPI-Compliant System
	(ISA) 0x00000074 (116)	Microsoft ACPI-Compliant System
	(ISA) 0x00000075 (117)	Microsoft ACPI-Compliant System
	(ISA) 0x00000076 (118)	Microsoft ACPI-Compliant System

 (ISA) 0x00000066 (102)	Microsoft ACPI-Compliant System
 (ISA) 0x00000067 (103)	Microsoft ACPI-Compliant System
 (ISA) 0x00000068 (104)	Microsoft ACPI-Compliant System
 (ISA) 0x00000069 (105)	Microsoft ACPI-Compliant System
 (ISA) 0x0000006A (106)	Microsoft ACPI-Compliant System
 (ISA) 0x0000006B (107)	Microsoft ACPI-Compliant System
 (ISA) 0x0000006C (108)	Microsoft ACPI-Compliant System
 (ISA) 0x0000006D (109)	Microsoft ACPI-Compliant System
 (ISA) 0x0000006E (110)	Microsoft ACPI-Compliant System
 (ISA) 0x0000006F (111)	Microsoft ACPI-Compliant System
 (ISA) 0x00000070 (112)	Microsoft ACPI-Compliant System
 (ISA) 0x00000071 (113)	Microsoft ACPI-Compliant System
 (ISA) 0x00000072 (114)	Microsoft ACPI-Compliant System
 (ISA) 0x00000073 (115)	Microsoft ACPI-Compliant System
 (ISA) 0x00000074 (116)	Microsoft ACPI-Compliant System
 (ISA) 0x00000075 (117)	Microsoft ACPI-Compliant System
 (ISA) 0x00000076 (118)	Microsoft ACPI-Compliant System
 (ISA) 0x00000077 (119)	Microsoft ACPI-Compliant System
 (ISA) 0x00000078 (120)	Microsoft ACPI-Compliant System
 (ISA) 0x00000079 (121)	Microsoft ACPI-Compliant System
 (ISA) 0x0000007A (122)	Microsoft ACPI-Compliant System
 (ISA) 0x0000007B (123)	Microsoft ACPI-Compliant System
 (ISA) 0x0000007C (124)	Microsoft ACPI-Compliant System
 (ISA) 0x0000007D (125)	Microsoft ACPI-Compliant System
 (ISA) 0x0000007E (126)	Microsoft ACPI-Compliant System
 (ISA) 0x0000007F (127)	Microsoft ACPI-Compliant System
 (ISA) 0x00000080 (128)	Microsoft ACPI-Compliant System
 (ISA) 0x00000081 (129)	Microsoft ACPI-Compliant System
 (ISA) 0x00000082 (130)	Microsoft ACPI-Compliant System
 (ISA) 0x00000083 (131)	Microsoft ACPI-Compliant System
 (ISA) 0x00000084 (132)	Microsoft ACPI-Compliant System
 (ISA) 0x00000085 (133)	Microsoft ACPI-Compliant System

 (ISA) 0x0000085 (133)	Microsoft ACPI-Compliant System
 (ISA) 0x0000086 (134)	Microsoft ACPI-Compliant System
 (ISA) 0x0000087 (135)	Microsoft ACPI-Compliant System
 (ISA) 0x0000088 (136)	Microsoft ACPI-Compliant System
 (ISA) 0x0000089 (137)	Microsoft ACPI-Compliant System
 (ISA) 0x000008A (138)	Microsoft ACPI-Compliant System
 (ISA) 0x000008B (139)	Microsoft ACPI-Compliant System
 (ISA) 0x000008C (140)	Microsoft ACPI-Compliant System
 (ISA) 0x000008D (141)	Microsoft ACPI-Compliant System
 (ISA) 0x000008E (142)	Microsoft ACPI-Compliant System
 (ISA) 0x000008F (143)	Microsoft ACPI-Compliant System
 (ISA) 0x0000090 (144)	Microsoft ACPI-Compliant System
 (ISA) 0x0000091 (145)	Microsoft ACPI-Compliant System
 (ISA) 0x0000092 (146)	Microsoft ACPI-Compliant System
 (ISA) 0x0000093 (147)	Microsoft ACPI-Compliant System
 (ISA) 0x0000094 (148)	Microsoft ACPI-Compliant System
 (ISA) 0x0000095 (149)	Microsoft ACPI-Compliant System
 (ISA) 0x0000096 (150)	Microsoft ACPI-Compliant System
 (ISA) 0x0000097 (151)	Microsoft ACPI-Compliant System
 (ISA) 0x0000098 (152)	Microsoft ACPI-Compliant System
 (ISA) 0x0000099 (153)	Microsoft ACPI-Compliant System
 (ISA) 0x000009A (154)	Microsoft ACPI-Compliant System
 (ISA) 0x000009B (155)	Microsoft ACPI-Compliant System
 (ISA) 0x000009C (156)	Microsoft ACPI-Compliant System
 (ISA) 0x000009D (157)	Microsoft ACPI-Compliant System
 (ISA) 0x000009E (158)	Microsoft ACPI-Compliant System
 (ISA) 0x000009F (159)	Microsoft ACPI-Compliant System
 (ISA) 0x00000A0 (160)	Microsoft ACPI-Compliant System
 (ISA) 0x00000A1 (161)	Microsoft ACPI-Compliant System
 (ISA) 0x00000A2 (162)	Microsoft ACPI-Compliant System
 (ISA) 0x00000A3 (163)	Microsoft ACPI-Compliant System
 (ISA) 0x00000A4 (164)	Microsoft ACPI-Compliant System

































---

































 (ISA) 0x000000A4 (164)	Microsoft ACPI-Compliant System
 (ISA) 0x000000A5 (165)	Microsoft ACPI-Compliant System
 (ISA) 0x000000A6 (166)	Microsoft ACPI-Compliant System
 (ISA) 0x000000A7 (167)	Microsoft ACPI-Compliant System
 (ISA) 0x000000A8 (168)	Microsoft ACPI-Compliant System
 (ISA) 0x000000A9 (169)	Microsoft ACPI-Compliant System
 (ISA) 0x000000AA (170)	Microsoft ACPI-Compliant System
 (ISA) 0x000000AB (171)	Microsoft ACPI-Compliant System
 (ISA) 0x000000AC (172)	Microsoft ACPI-Compliant System
 (ISA) 0x000000AD (173)	Microsoft ACPI-Compliant System
 (ISA) 0x000000AE (174)	Microsoft ACPI-Compliant System
 (ISA) 0x000000AF (175)	Microsoft ACPI-Compliant System
 (ISA) 0x000000B0 (176)	Microsoft ACPI-Compliant System
 (ISA) 0x000000B1 (177)	Microsoft ACPI-Compliant System
 (ISA) 0x000000B2 (178)	Microsoft ACPI-Compliant System
 (ISA) 0x000000B3 (179)	Microsoft ACPI-Compliant System
 (ISA) 0x000000B4 (180)	Microsoft ACPI-Compliant System
 (ISA) 0x000000B5 (181)	Microsoft ACPI-Compliant System
 (ISA) 0x000000B6 (182)	Microsoft ACPI-Compliant System
 (ISA) 0x000000B7 (183)	Microsoft ACPI-Compliant System
 (ISA) 0x000000B8 (184)	Microsoft ACPI-Compliant System
 (ISA) 0x000000B9 (185)	Microsoft ACPI-Compliant System
 (ISA) 0x000000BA (186)	Microsoft ACPI-Compliant System
 (ISA) 0x000000BB (187)	Microsoft ACPI-Compliant System
 (ISA) 0x000000BC (188)	Microsoft ACPI-Compliant System
 (ISA) 0x000000BD (189)	Microsoft ACPI-Compliant System
 (ISA) 0x000000BE (190)	Microsoft ACPI-Compliant System
 (ISA) 0x000000BF (191)	Microsoft ACPI-Compliant System
 (ISA) 0x00000100 (256)	Microsoft ACPI-Compliant System
 (ISA) 0x00000101 (257)	Microsoft ACPI-Compliant System
 (ISA) 0x00000102 (258)	Microsoft ACPI-Compliant System
 (ISA) 0x00000103 (259)	Microsoft ACPI-Compliant System

































 (ISA) 0x00000103 (259)	Microsoft ACPI-Compliant System
 (ISA) 0x00000104 (260)	Microsoft ACPI-Compliant System
 (ISA) 0x00000105 (261)	Microsoft ACPI-Compliant System
 (ISA) 0x00000106 (262)	Microsoft ACPI-Compliant System
 (ISA) 0x00000107 (263)	Microsoft ACPI-Compliant System
 (ISA) 0x00000108 (264)	Microsoft ACPI-Compliant System
 (ISA) 0x00000109 (265)	Microsoft ACPI-Compliant System
 (ISA) 0x0000010A (266)	Microsoft ACPI-Compliant System
 (ISA) 0x0000010B (267)	Microsoft ACPI-Compliant System
 (ISA) 0x0000010C (268)	Microsoft ACPI-Compliant System
 (ISA) 0x0000010D (269)	Microsoft ACPI-Compliant System
 (ISA) 0x0000010E (270)	Microsoft ACPI-Compliant System
 (ISA) 0x0000010F (271)	Microsoft ACPI-Compliant System
 (ISA) 0x00000110 (272)	Microsoft ACPI-Compliant System
 (ISA) 0x00000111 (273)	Microsoft ACPI-Compliant System
 (ISA) 0x00000112 (274)	Microsoft ACPI-Compliant System
 (ISA) 0x00000113 (275)	Microsoft ACPI-Compliant System
 (ISA) 0x00000114 (276)	Microsoft ACPI-Compliant System
 (ISA) 0x00000115 (277)	Microsoft ACPI-Compliant System
 (ISA) 0x00000116 (278)	Microsoft ACPI-Compliant System
 (ISA) 0x00000117 (279)	Microsoft ACPI-Compliant System
 (ISA) 0x00000118 (280)	Microsoft ACPI-Compliant System
 (ISA) 0x00000119 (281)	Microsoft ACPI-Compliant System
 (ISA) 0x0000011A (282)	Microsoft ACPI-Compliant System
 (ISA) 0x0000011B (283)	Microsoft ACPI-Compliant System
 (ISA) 0x0000011C (284)	Microsoft ACPI-Compliant System
 (ISA) 0x0000011D (285)	Microsoft ACPI-Compliant System
 (ISA) 0x0000011E (286)	Microsoft ACPI-Compliant System
 (ISA) 0x0000011F (287)	Microsoft ACPI-Compliant System
 (ISA) 0x00000120 (288)	Microsoft ACPI-Compliant System
 (ISA) 0x00000121 (289)	Microsoft ACPI-Compliant System
 (ISA) 0x00000122 (290)	Microsoft ACPI-Compliant System



































































---

































 (ISA) 0x00000122 (290)	Microsoft ACPI-Compliant System
 (ISA) 0x00000123 (291)	Microsoft ACPI-Compliant System
 (ISA) 0x00000124 (292)	Microsoft ACPI-Compliant System
 (ISA) 0x00000125 (293)	Microsoft ACPI-Compliant System
 (ISA) 0x00000126 (294)	Microsoft ACPI-Compliant System
 (ISA) 0x00000127 (295)	Microsoft ACPI-Compliant System
 (ISA) 0x00000128 (296)	Microsoft ACPI-Compliant System
 (ISA) 0x00000129 (297)	Microsoft ACPI-Compliant System
 (ISA) 0x0000012A (298)	Microsoft ACPI-Compliant System
 (ISA) 0x0000012B (299)	Microsoft ACPI-Compliant System
 (ISA) 0x0000012C (300)	Microsoft ACPI-Compliant System
 (ISA) 0x0000012D (301)	Microsoft ACPI-Compliant System
 (ISA) 0x0000012E (302)	Microsoft ACPI-Compliant System
 (ISA) 0x0000012F (303)	Microsoft ACPI-Compliant System
 (ISA) 0x00000130 (304)	Microsoft ACPI-Compliant System
 (ISA) 0x00000131 (305)	Microsoft ACPI-Compliant System
 (ISA) 0x00000132 (306)	Microsoft ACPI-Compliant System
 (ISA) 0x00000133 (307)	Microsoft ACPI-Compliant System
 (ISA) 0x00000134 (308)	Microsoft ACPI-Compliant System
 (ISA) 0x00000135 (309)	Microsoft ACPI-Compliant System
 (ISA) 0x00000136 (310)	Microsoft ACPI-Compliant System
 (ISA) 0x00000137 (311)	Microsoft ACPI-Compliant System
 (ISA) 0x00000138 (312)	Microsoft ACPI-Compliant System
 (ISA) 0x00000139 (313)	Microsoft ACPI-Compliant System
 (ISA) 0x0000013A (314)	Microsoft ACPI-Compliant System
 (ISA) 0x0000013B (315)	Microsoft ACPI-Compliant System
 (ISA) 0x0000013C (316)	Microsoft ACPI-Compliant System
 (ISA) 0x0000013D (317)	Microsoft ACPI-Compliant System
 (ISA) 0x0000013E (318)	Microsoft ACPI-Compliant System
 (ISA) 0x0000013F (319)	Microsoft ACPI-Compliant System
 (ISA) 0x00000140 (320)	Microsoft ACPI-Compliant System
 (ISA) 0x00000141 (321)	Microsoft ACPI-Compliant System

































 (ISA) 0x00000141 (321)	Microsoft ACPI-Compliant System
 (ISA) 0x00000142 (322)	Microsoft ACPI-Compliant System
 (ISA) 0x00000143 (323)	Microsoft ACPI-Compliant System
 (ISA) 0x00000144 (324)	Microsoft ACPI-Compliant System
 (ISA) 0x00000145 (325)	Microsoft ACPI-Compliant System
 (ISA) 0x00000146 (326)	Microsoft ACPI-Compliant System
 (ISA) 0x00000147 (327)	Microsoft ACPI-Compliant System
 (ISA) 0x00000148 (328)	Microsoft ACPI-Compliant System
 (ISA) 0x00000149 (329)	Microsoft ACPI-Compliant System
 (ISA) 0x0000014A (330)	Microsoft ACPI-Compliant System
 (ISA) 0x0000014B (331)	Microsoft ACPI-Compliant System
 (ISA) 0x0000014C (332)	Microsoft ACPI-Compliant System
 (ISA) 0x0000014D (333)	Microsoft ACPI-Compliant System
 (ISA) 0x0000014E (334)	Microsoft ACPI-Compliant System
 (ISA) 0x0000014F (335)	Microsoft ACPI-Compliant System
 (ISA) 0x00000150 (336)	Microsoft ACPI-Compliant System
 (ISA) 0x00000151 (337)	Microsoft ACPI-Compliant System
 (ISA) 0x00000152 (338)	Microsoft ACPI-Compliant System
 (ISA) 0x00000153 (339)	Microsoft ACPI-Compliant System
 (ISA) 0x00000154 (340)	Microsoft ACPI-Compliant System
 (ISA) 0x00000155 (341)	Microsoft ACPI-Compliant System
 (ISA) 0x00000156 (342)	Microsoft ACPI-Compliant System
 (ISA) 0x00000157 (343)	Microsoft ACPI-Compliant System
 (ISA) 0x00000158 (344)	Microsoft ACPI-Compliant System
 (ISA) 0x00000159 (345)	Microsoft ACPI-Compliant System
 (ISA) 0x0000015A (346)	Microsoft ACPI-Compliant System
 (ISA) 0x0000015B (347)	Microsoft ACPI-Compliant System
 (ISA) 0x0000015C (348)	Microsoft ACPI-Compliant System
 (ISA) 0x0000015D (349)	Microsoft ACPI-Compliant System
 (ISA) 0x0000015E (350)	Microsoft ACPI-Compliant System
 (ISA) 0x0000015F (351)	Microsoft ACPI-Compliant System
 (ISA) 0x00000160 (352)	Microsoft ACPI-Compliant System

























 (ISA) 0x00000160 (352)	Microsoft ACPI-Compliant System
 (ISA) 0x00000161 (353)	Microsoft ACPI-Compliant System
 (ISA) 0x00000162 (354)	Microsoft ACPI-Compliant System
 (ISA) 0x00000163 (355)	Microsoft ACPI-Compliant System
 (ISA) 0x00000164 (356)	Microsoft ACPI-Compliant System
 (ISA) 0x00000165 (357)	Microsoft ACPI-Compliant System
 (ISA) 0x00000166 (358)	Microsoft ACPI-Compliant System
 (ISA) 0x00000167 (359)	Microsoft ACPI-Compliant System
 (ISA) 0x00000168 (360)	Microsoft ACPI-Compliant System
 (ISA) 0x00000169 (361)	Microsoft ACPI-Compliant System
 (ISA) 0x0000016A (362)	Microsoft ACPI-Compliant System
 (ISA) 0x0000016B (363)	Microsoft ACPI-Compliant System
 (ISA) 0x0000016C (364)	Microsoft ACPI-Compliant System
 (ISA) 0x0000016D (365)	Microsoft ACPI-Compliant System
 (ISA) 0x0000016E (366)	Microsoft ACPI-Compliant System
 (ISA) 0x0000016F (367)	Microsoft ACPI-Compliant System
 (ISA) 0x00000170 (368)	Microsoft ACPI-Compliant System
 (ISA) 0x00000171 (369)	Microsoft ACPI-Compliant System
 (ISA) 0x00000172 (370)	Microsoft ACPI-Compliant System
 (ISA) 0x00000173 (371)	Microsoft ACPI-Compliant System
 (ISA) 0x00000174 (372)	Microsoft ACPI-Compliant System
 (ISA) 0x00000175 (373)	Microsoft ACPI-Compliant System
 (ISA) 0x00000176 (374)	Microsoft ACPI-Compliant System
 (ISA) 0x00000177 (375)	Microsoft ACPI-Compliant System
 (ISA) 0x00000178 (376)	Microsoft ACPI-Compliant System
 (ISA) 0x00000179 (377)	Microsoft ACPI-Compliant System
 (ISA) 0x0000017A (378)	Microsoft ACPI-Compliant System
 (ISA) 0x0000017B (379)	Microsoft ACPI-Compliant System
 (ISA) 0x0000017C (380)	Microsoft ACPI-Compliant System
 (ISA) 0x0000017D (381)	Microsoft ACPI-Compliant System
 (ISA) 0x0000017E (382)	Microsoft ACPI-Compliant System
 (ISA) 0x0000017F (383)	Microsoft ACPI-Compliant System

 (ISA) 0x0000017F (383)	Microsoft ACPI-Compliant System
 (ISA) 0x00000180 (384)	Microsoft ACPI-Compliant System
 (ISA) 0x00000181 (385)	Microsoft ACPI-Compliant System
 (ISA) 0x00000182 (386)	Microsoft ACPI-Compliant System
 (ISA) 0x00000183 (387)	Microsoft ACPI-Compliant System
 (ISA) 0x00000184 (388)	Microsoft ACPI-Compliant System
 (ISA) 0x00000185 (389)	Microsoft ACPI-Compliant System
 (ISA) 0x00000186 (390)	Microsoft ACPI-Compliant System
 (ISA) 0x00000187 (391)	Microsoft ACPI-Compliant System
 (ISA) 0x00000188 (392)	Microsoft ACPI-Compliant System
 (ISA) 0x00000189 (393)	Microsoft ACPI-Compliant System
 (ISA) 0x0000018A (394)	Microsoft ACPI-Compliant System
 (ISA) 0x0000018B (395)	Microsoft ACPI-Compliant System
 (ISA) 0x0000018C (396)	Microsoft ACPI-Compliant System
 (ISA) 0x0000018D (397)	Microsoft ACPI-Compliant System
 (ISA) 0x0000018E (398)	Microsoft ACPI-Compliant System
 (ISA) 0x0000018F (399)	Microsoft ACPI-Compliant System
 (ISA) 0x00000190 (400)	Microsoft ACPI-Compliant System
 (ISA) 0x00000191 (401)	Microsoft ACPI-Compliant System
 (ISA) 0x00000192 (402)	Microsoft ACPI-Compliant System
 (ISA) 0x00000193 (403)	Microsoft ACPI-Compliant System
 (ISA) 0x00000194 (404)	Microsoft ACPI-Compliant System
 (ISA) 0x00000195 (405)	Microsoft ACPI-Compliant System
 (ISA) 0x00000196 (406)	Microsoft ACPI-Compliant System
 (ISA) 0x00000197 (407)	Microsoft ACPI-Compliant System
 (ISA) 0x00000198 (408)	Microsoft ACPI-Compliant System
 (ISA) 0x00000199 (409)	Microsoft ACPI-Compliant System
 (ISA) 0x0000019A (410)	Microsoft ACPI-Compliant System
 (ISA) 0x0000019B (411)	Microsoft ACPI-Compliant System
 (ISA) 0x0000019C (412)	Microsoft ACPI-Compliant System
 (ISA) 0x0000019D (413)	Microsoft ACPI-Compliant System
 (ISA) 0x0000019E (414)	Microsoft ACPI-Compliant System

 (ISA) 0x0000019E (414)	Microsoft ACPI-Compliant System
 (ISA) 0x0000019F (415)	Microsoft ACPI-Compliant System
 (ISA) 0x000001A0 (416)	Microsoft ACPI-Compliant System
 (ISA) 0x000001A1 (417)	Microsoft ACPI-Compliant System
 (ISA) 0x000001A2 (418)	Microsoft ACPI-Compliant System
 (ISA) 0x000001A3 (419)	Microsoft ACPI-Compliant System
 (ISA) 0x000001A4 (420)	Microsoft ACPI-Compliant System
 (ISA) 0x000001A5 (421)	Microsoft ACPI-Compliant System
 (ISA) 0x000001A6 (422)	Microsoft ACPI-Compliant System
 (ISA) 0x000001A7 (423)	Microsoft ACPI-Compliant System
 (ISA) 0x000001A8 (424)	Microsoft ACPI-Compliant System
 (ISA) 0x000001A9 (425)	Microsoft ACPI-Compliant System
 (ISA) 0x000001AA (426)	Microsoft ACPI-Compliant System
 (ISA) 0x000001AB (427)	Microsoft ACPI-Compliant System
 (ISA) 0x000001AC (428)	Microsoft ACPI-Compliant System
 (ISA) 0x000001AD (429)	Microsoft ACPI-Compliant System
 (ISA) 0x000001AE (430)	Microsoft ACPI-Compliant System
 (ISA) 0x000001AF (431)	Microsoft ACPI-Compliant System
 (ISA) 0x000001B0 (432)	Microsoft ACPI-Compliant System
 (ISA) 0x000001B1 (433)	Microsoft ACPI-Compliant System
 (ISA) 0x000001B2 (434)	Microsoft ACPI-Compliant System
 (ISA) 0x000001B3 (435)	Microsoft ACPI-Compliant System
 (ISA) 0x000001B4 (436)	Microsoft ACPI-Compliant System
 (ISA) 0x000001B5 (437)	Microsoft ACPI-Compliant System
 (ISA) 0x000001B6 (438)	Microsoft ACPI-Compliant System
 (ISA) 0x000001B7 (439)	Microsoft ACPI-Compliant System
 (ISA) 0x000001B8 (440)	Microsoft ACPI-Compliant System
 (ISA) 0x000001B9 (441)	Microsoft ACPI-Compliant System
 (ISA) 0x000001BA (442)	Microsoft ACPI-Compliant System
 (ISA) 0x000001BB (443)	Microsoft ACPI-Compliant System
 (ISA) 0x000001BC (444)	Microsoft ACPI-Compliant System
 (ISA) 0x000001BD (445)	Microsoft ACPI-Compliant System

 (ISA) 0x000001BD (445)	Microsoft ACPI-Compliant System
 (ISA) 0x000001BE (446)	Microsoft ACPI-Compliant System
 (ISA) 0x000001BF (447)	Microsoft ACPI-Compliant System
 (ISA) 0x000001C0 (448)	Microsoft ACPI-Compliant System
 (ISA) 0x000001C1 (449)	Microsoft ACPI-Compliant System
 (ISA) 0x000001C2 (450)	Microsoft ACPI-Compliant System
 (ISA) 0x000001C3 (451)	Microsoft ACPI-Compliant System
 (ISA) 0x000001C4 (452)	Microsoft ACPI-Compliant System
 (ISA) 0x000001C5 (453)	Microsoft ACPI-Compliant System
 (ISA) 0x000001C6 (454)	Microsoft ACPI-Compliant System
 (ISA) 0x000001C7 (455)	Microsoft ACPI-Compliant System
 (ISA) 0x000001C8 (456)	Microsoft ACPI-Compliant System
 (ISA) 0x000001C9 (457)	Microsoft ACPI-Compliant System
 (ISA) 0x000001CA (458)	Microsoft ACPI-Compliant System
 (ISA) 0x000001CB (459)	Microsoft ACPI-Compliant System
 (ISA) 0x000001CC (460)	Microsoft ACPI-Compliant System
 (ISA) 0x000001CD (461)	Microsoft ACPI-Compliant System
 (ISA) 0x000001CE (462)	Microsoft ACPI-Compliant System
 (ISA) 0x000001CF (463)	Microsoft ACPI-Compliant System
 (ISA) 0x000001D0 (464)	Microsoft ACPI-Compliant System
 (ISA) 0x000001D1 (465)	Microsoft ACPI-Compliant System
 (ISA) 0x000001D2 (466)	Microsoft ACPI-Compliant System
 (ISA) 0x000001D3 (467)	Microsoft ACPI-Compliant System
 (ISA) 0x000001D4 (468)	Microsoft ACPI-Compliant System
 (ISA) 0x000001D5 (469)	Microsoft ACPI-Compliant System
 (ISA) 0x000001D6 (470)	Microsoft ACPI-Compliant System
 (ISA) 0x000001D7 (471)	Microsoft ACPI-Compliant System
 (ISA) 0x000001D8 (472)	Microsoft ACPI-Compliant System
 (ISA) 0x000001D9 (473)	Microsoft ACPI-Compliant System
 (ISA) 0x000001DA (474)	Microsoft ACPI-Compliant System
 (ISA) 0x000001DB (475)	Microsoft ACPI-Compliant System
 (ISA) 0x000001DC (476)	Microsoft ACPI-Compliant System







 (ISA) 0x000001DC (476)	Microsoft ACPI-Compliant System
 (ISA) 0x000001DD (477)	Microsoft ACPI-Compliant System
 (ISA) 0x000001DE (478)	Microsoft ACPI-Compliant System
 (ISA) 0x000001DF (479)	Microsoft ACPI-Compliant System
 (ISA) 0x000001E0 (480)	Microsoft ACPI-Compliant System
 (ISA) 0x000001E1 (481)	Microsoft ACPI-Compliant System
 (ISA) 0x000001E2 (482)	Microsoft ACPI-Compliant System
 (ISA) 0x000001E3 (483)	Microsoft ACPI-Compliant System
 (ISA) 0x000001E4 (484)	Microsoft ACPI-Compliant System
 (ISA) 0x000001E5 (485)	Microsoft ACPI-Compliant System
 (ISA) 0x000001E6 (486)	Microsoft ACPI-Compliant System
 (ISA) 0x000001E7 (487)	Microsoft ACPI-Compliant System
 (ISA) 0x000001E8 (488)	Microsoft ACPI-Compliant System
 (ISA) 0x000001E9 (489)	Microsoft ACPI-Compliant System
 (ISA) 0x000001EA (490)	Microsoft ACPI-Compliant System
 (ISA) 0x000001EB (491)	Microsoft ACPI-Compliant System
 (ISA) 0x000001EC (492)	Microsoft ACPI-Compliant System
 (ISA) 0x000001ED (493)	Microsoft ACPI-Compliant System
 (ISA) 0x000001EE (494)	Microsoft ACPI-Compliant System
 (ISA) 0x000001EF (495)	Microsoft ACPI-Compliant System
 (ISA) 0x000001F0 (496)	Microsoft ACPI-Compliant System
 (ISA) 0x000001F1 (497)	Microsoft ACPI-Compliant System
 (ISA) 0x000001F2 (498)	Microsoft ACPI-Compliant System
 (ISA) 0x000001F3 (499)	Microsoft ACPI-Compliant System
 (ISA) 0x000001F4 (500)	Microsoft ACPI-Compliant System
 (ISA) 0x000001F5 (501)	Microsoft ACPI-Compliant System
 (ISA) 0x000001F6 (502)	Microsoft ACPI-Compliant System
 (ISA) 0x000001F7 (503)	Microsoft ACPI-Compliant System
 (ISA) 0x000001F8 (504)	Microsoft ACPI-Compliant System
 (ISA) 0x000001F9 (505)	Microsoft ACPI-Compliant System
 (ISA) 0x000001FA (506)	Microsoft ACPI-Compliant System
 (ISA) 0x000001FB (507)	Microsoft ACPI-Compliant System

 (ISA) 0x000001FB (507)	Microsoft ACPI-Compliant System
 (ISA) 0x000001FC (508)	Microsoft ACPI-Compliant System
 (ISA) 0x000001FD (509)	Microsoft ACPI-Compliant System
 (ISA) 0x000001FE (510)	Microsoft ACPI-Compliant System
 (ISA) 0x000001FF (511)	Microsoft ACPI-Compliant System
 (PCI) 0x0000000B (11)	Intel(R) 7 Series/C216 Chipset Family SMBus Host Controller - 1E22
 (PCI) 0x00000010 (16)	Intel(R) 7 Series/C216 Chipset Family USB Enhanced Host Controller - 1E2D
 (PCI) 0x00000010 (16)	Intel(R) 7 Series/C216 Chipset Family PCI Express Root Port 1 - 1E10
 (PCI) 0x00000010 (16)	Intel(R) Management Engine Interface
 (PCI) 0x00000010 (16)	Xeon(R) processor E3-1200 v2/3rd Gen Core processor PCI Express Root Port - 015
 (PCI) 0x00000010 (16)	Xeon(R) processor E3-1200 v2/3rd Gen Core processor PCI Express Root Port - 015
 (PCI) 0x00000011 (17)	Intel(R) 7 Series/C216 Chipset Family PCI Express Root Port 2 - 1E12
 (PCI) 0x00000013 (19)	Intel(R) 7 Series/C216 Chipset Family 4 port Serial ATA Storage Controller - 1E01
 (PCI) 0x00000013 (19)	Intel(R) 7 Series/C216 Chipset Family 2 port Serial ATA Storage Controller - 1E09
 (PCI) 0x00000013 (19)	Intel(R) Active Management Technology - SOL (COM5)
 (PCI) 0x00000016 (22)	High Definition Audio Controller
 (PCI) 0x00000017 (23)	Intel(R) 7 Series/C216 Chipset Family USB Enhanced Host Controller - 1E26
 (PCI) 0xFFFFFFFF8 (-8)	Intel(R) 82574L Gigabit Network Connection
 (PCI) 0xFFFFFFFF9 (-7)	Intel(R) 82574L Gigabit Network Connection
 (PCI) 0xFFFFFFFFA (-6)	Intel(R) 82574L Gigabit Network Connection
 (PCI) 0xFFFFFFFFB (-5)	Intel(R) 82574L Gigabit Network Connection
 (PCI) 0xFFFFFFFFC (-4)	Intel(R) 82579LM Gigabit Network Connection
 (PCI) 0xFFFFFFFFD (-3)	Intel(R) USB 3.0 eXtensible Host Controller - 0100 (Microsoft)
 (PCI) 0xFFFFFFFFE (-2)	Intel(R) HD Graphics 4000



## B.4 DMA Channel Assignments

---

- ▶  test
  - ▶  Direct memory access (DMA)
    - ▶  4 Direct memory access controller
  - ▶  Input/output (IO)
  - ▶  Interrupt request (IRQ)
  - ▶  Memory

# Appendix C

---

RAID & AHCI Settings

## C.1 Setting RAID

---

OS installation to setup RAID Mode

Step 1: Copy the files below from "*Driver CD ->Step 7 - RAID&AHCI*" to Disk



Step 2: Connect the USB Floppy (disk with RAID files) to the board



Step 3: The setting procedures "In BIOS Setup Menu"  
 A: Advanced -> SATA Configuration -> SATA Mode -> RAID Mode

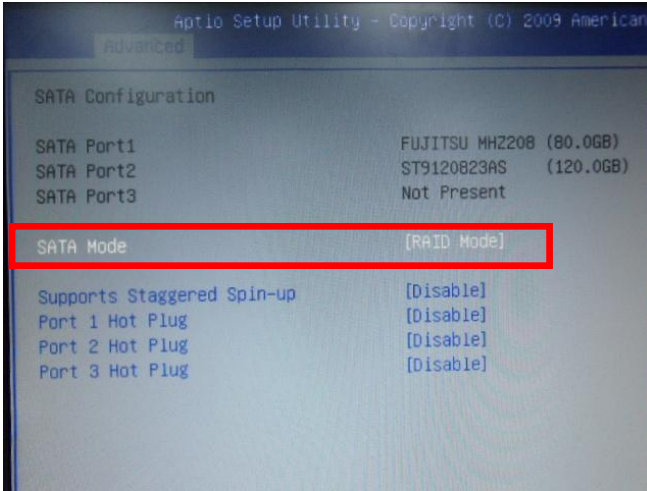

Step 4: The setting procedures "In BIOS Setup Menu"  
 B: Advanced -> Launch Storage OpROM -> Enabled

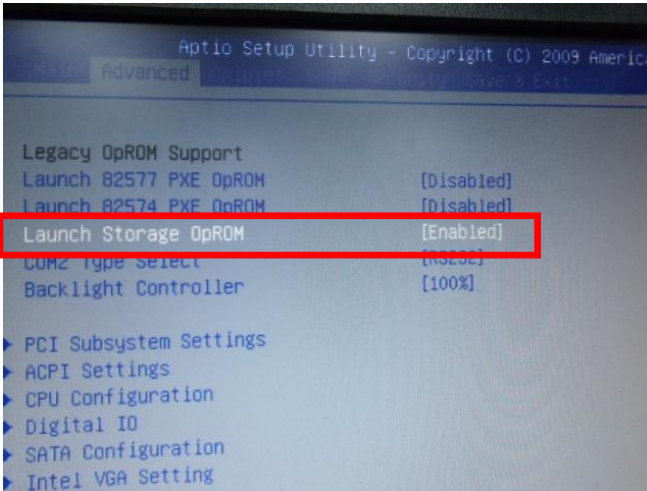

Step 5: The setting procedures "In BIOS Setup Menu"

C: Boot -> Boot Option #1 -> DVD-ROM Type

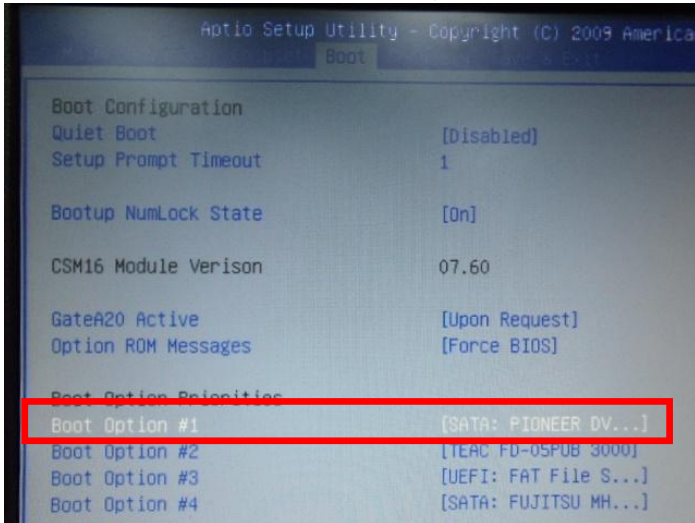

Step 6: The setting procedures "In BIOS Setup Menu"

D: Save & Exit -> Save Changes and Exit

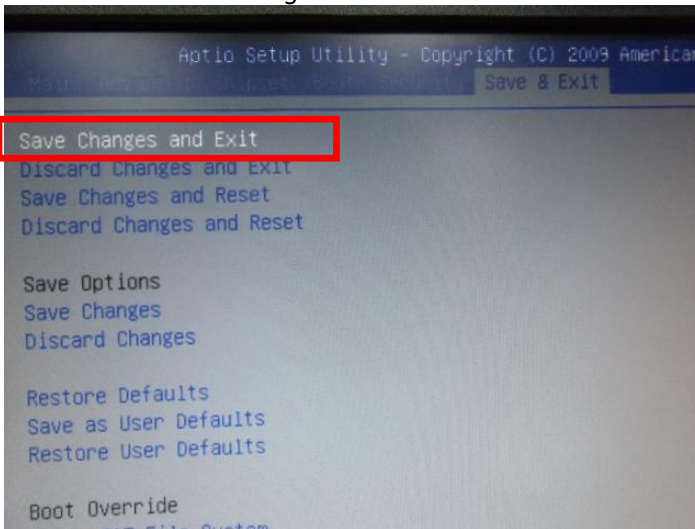

Step 7: Press **Ctrl-I** to enter **MAIN MENU**

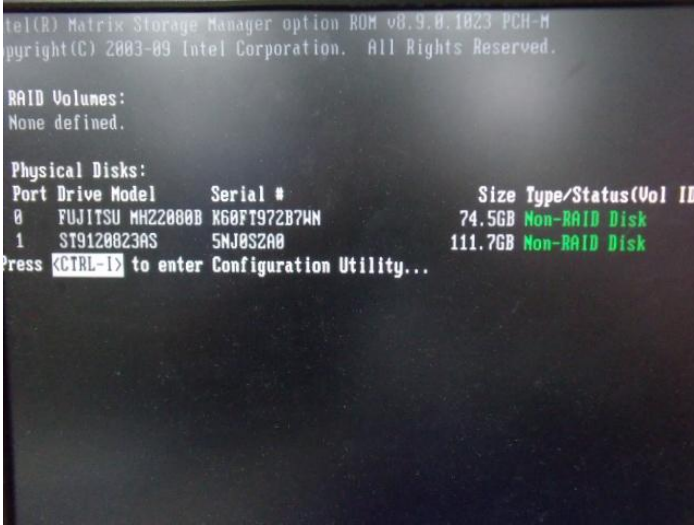

Step 8: Choose "1.Create RAID Volume"

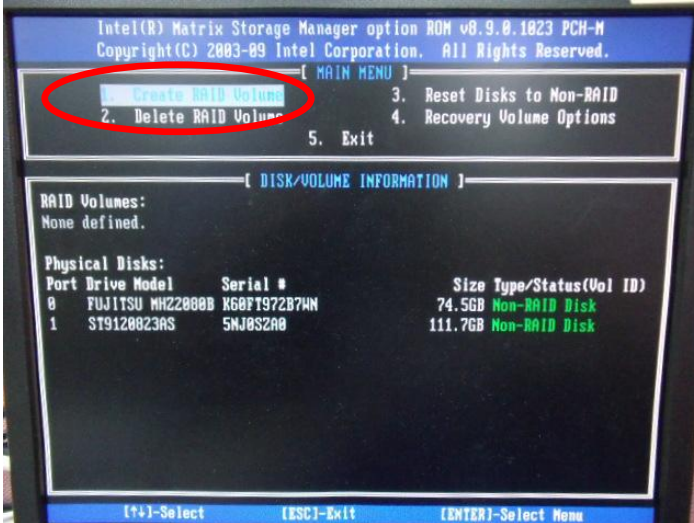

Step 9: RAID Level -> RAID0(Stripe)

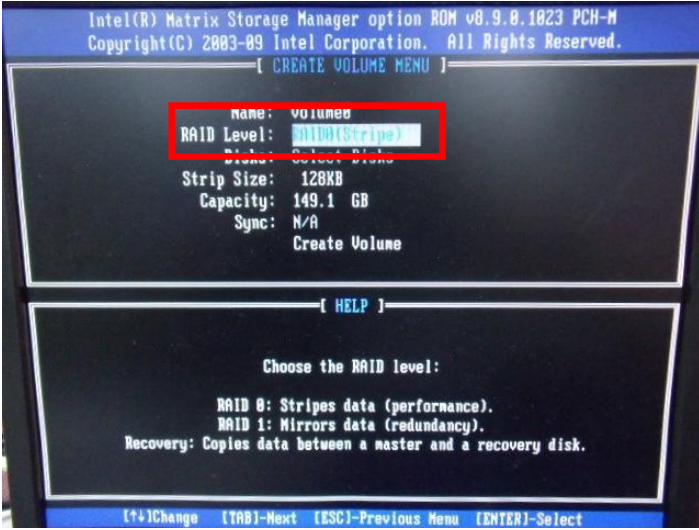

Step 10: Choose "Create Volume"

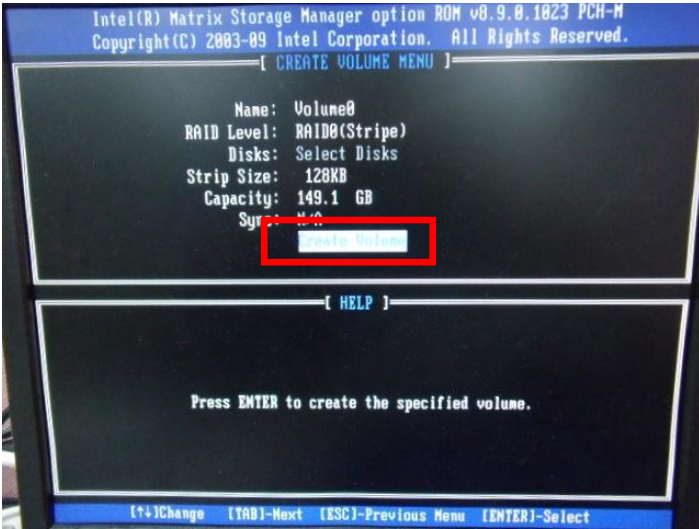

Step 11: Choose "Y"



Step 12: Choose "5. Exit"

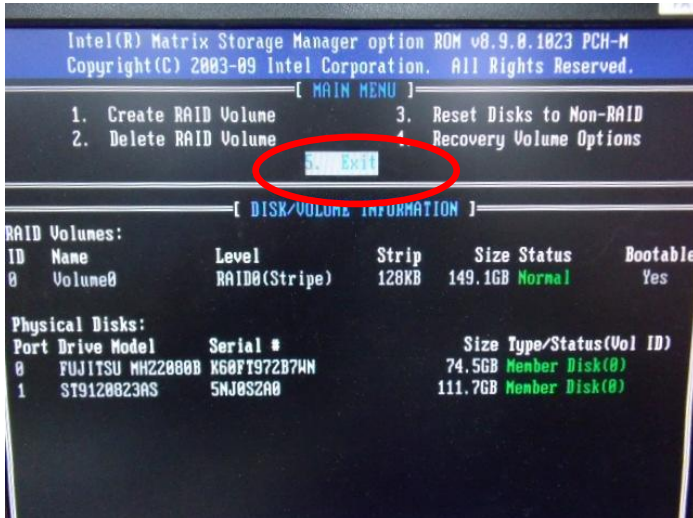



Step 13: Choose "Y"

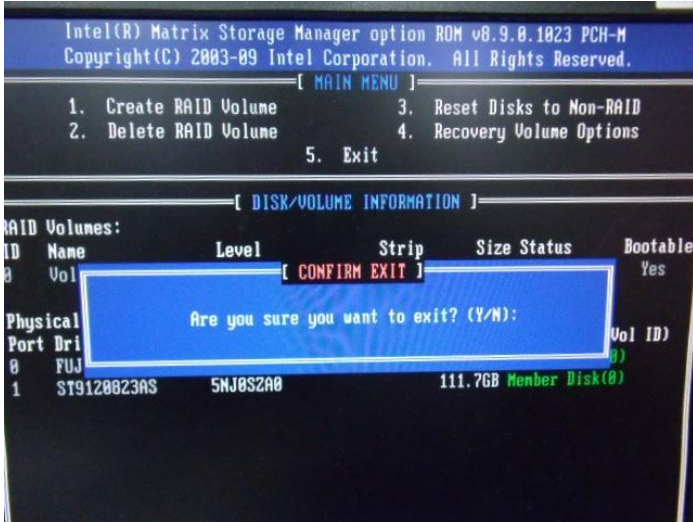

Step 14: Setup OS

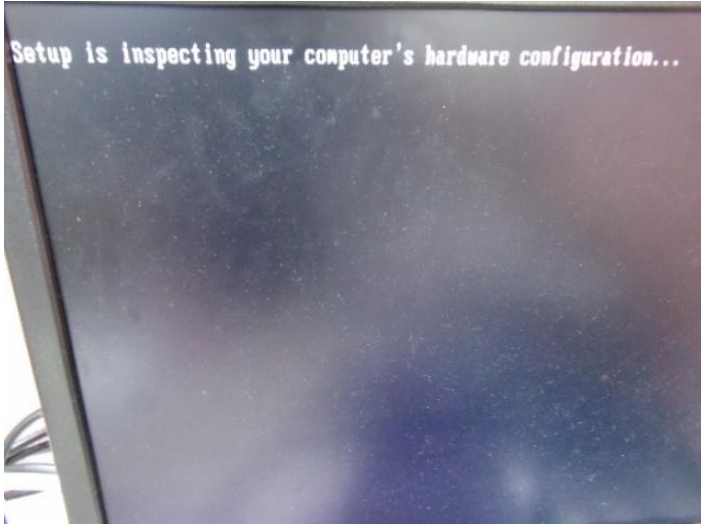

Step 15: Press "F6"



Step 16: Choose "S"

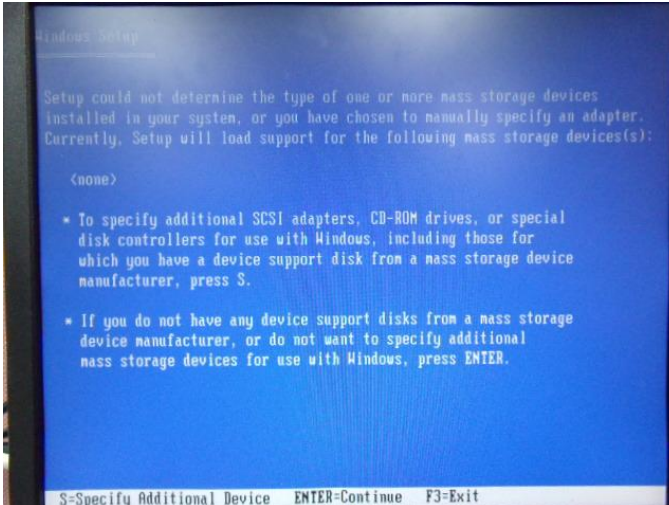

Step 17: Choose "Intel(R) Mobile Express Chipset SATA RAID Controller"

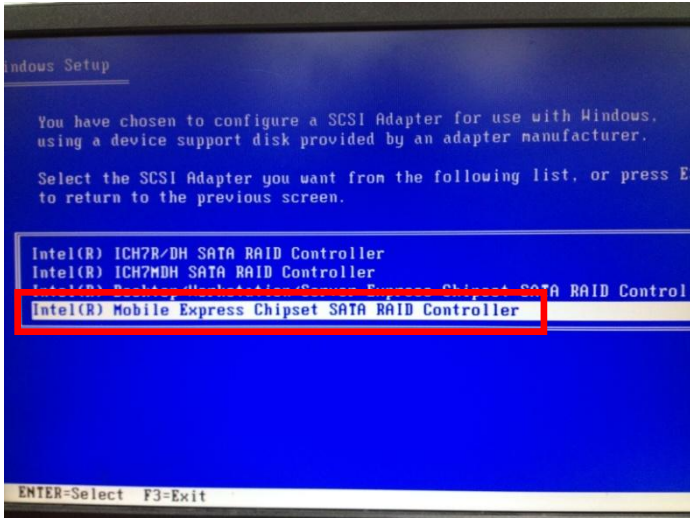

Step 18: It will show the model number you select and then press "ENTER"



Step 19: Setup is starting Windows

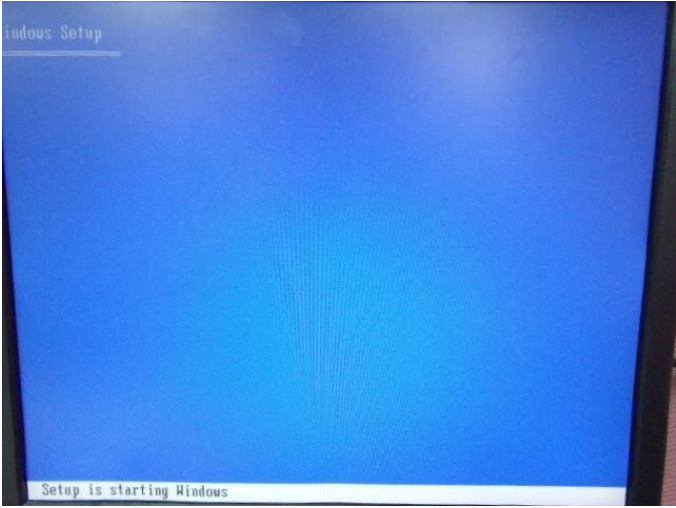

## C.2 Setting AHCI

OS installation to setup AHCI Mode

Step 1: Copy the files below from "Driver CD -> Step 7 - RAID&AHCI" to Disk



Step 2: Connect the USB Floppy (disk with AHCI files) to the board



Step 3: The setting procedures "In BIOS Setup Menu"

A: Advanced -> SATA Configuration -> SATA Configuration -> SATA Mode -> AHCI Mode

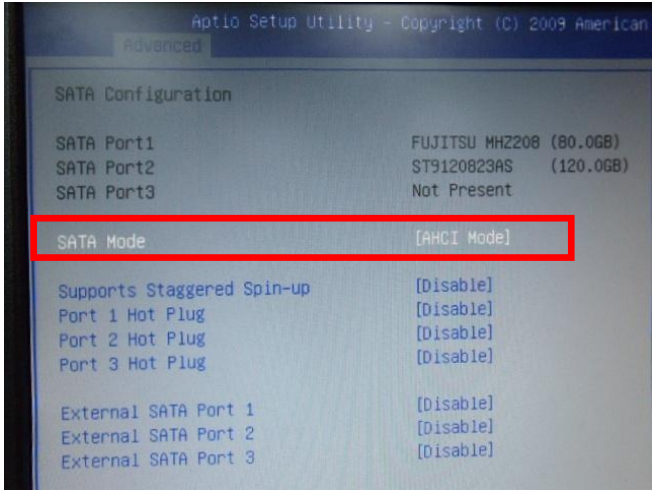

Step 4: The setting procedures "In BIOS Setup Menu"

B: Boot -> Boot Option #1 -> DVD-ROM Type

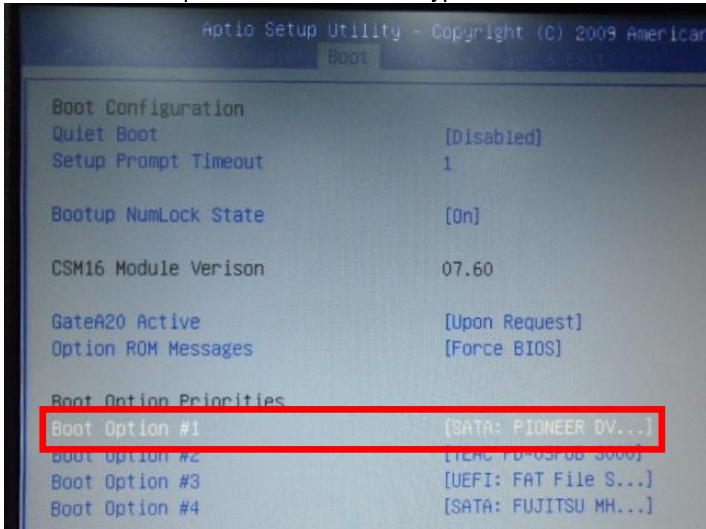

Step 5: The setting procedures "In BIOS Setup Menu"  
C: Save & Exit -> Save Changes and Exit

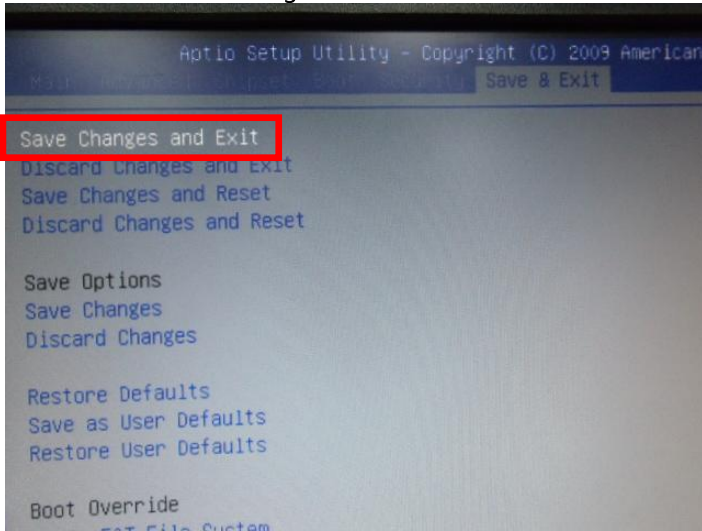

Step 6: Setup OS

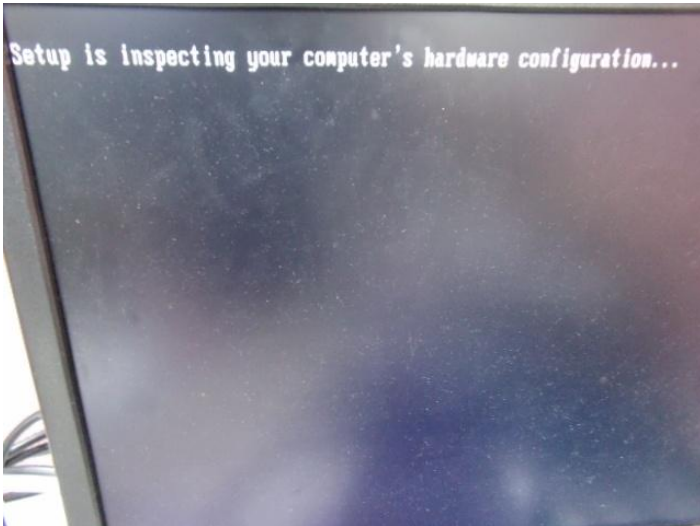

Step 7: Press "F6"

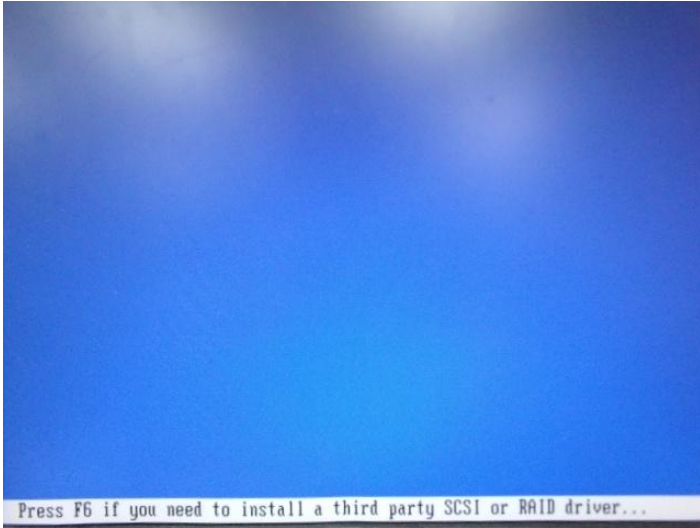

Step 8: Choose "S"

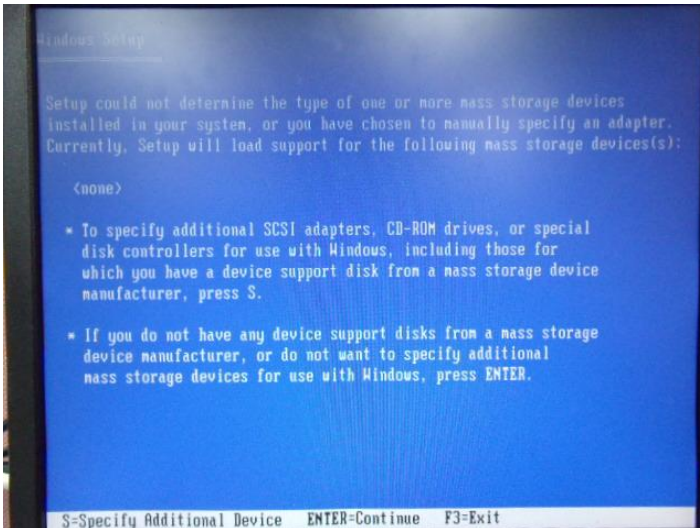



Step 9: Choose "Intel(R) 7 Series Chipset Family SATA AHCI Controller"

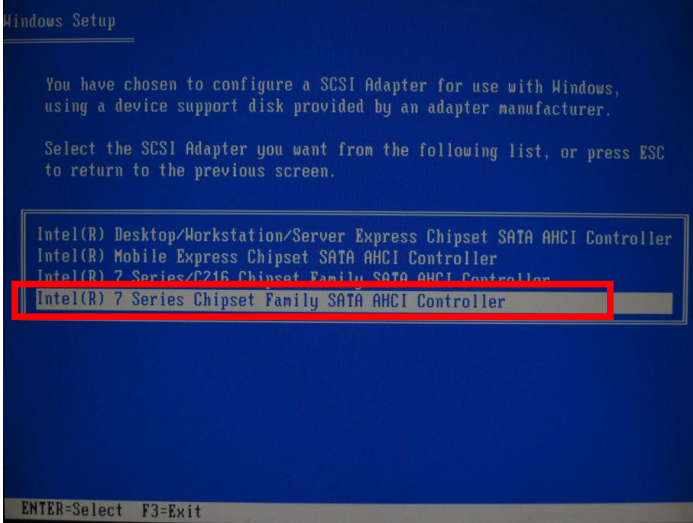

Step 10: It will show the model number you select and then press "ENTER"

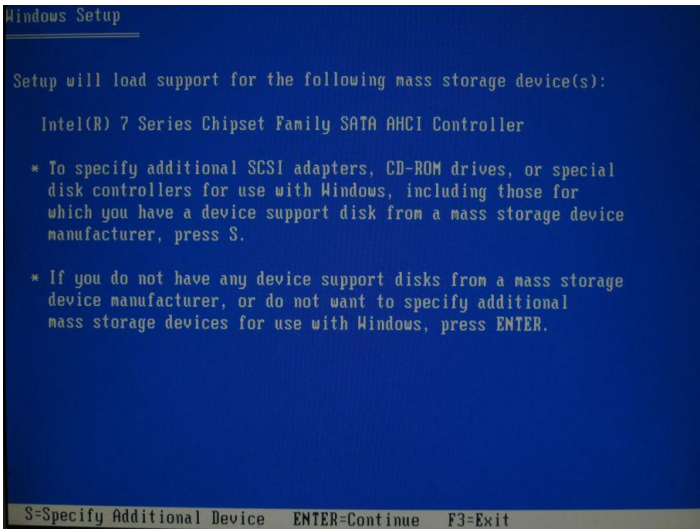

Step 11: Setup is loading files

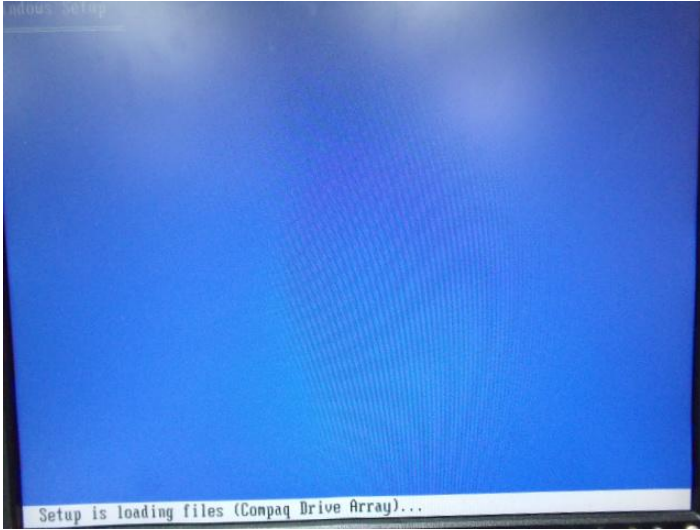

# Appendix D

---

Digital I/O Ports

## D.1 DI/O Programming

---

BOXER-6357VS utilizes FINTEK F81866 chipset as its Digital I/O controller. Below are the procedures to complete its configuration. AAeon initial DI/O program is also attached for developing customized program for your application.

There are three steps to complete the configuration setup:

- (1) Enter the MB PnP Mode
- (2) Modify the data of configuration registers
- (3) Exit the MB PnP Mode. Undesired result may occur if the MB PnP Mode is not exited normally.

## D.2 Digital I/O Register

Table 1 : SuperIO relative register table		
	Default Value	Note
Index	0x2E(Note1)	SIO MB PnP Mode Index Register 0x2E or 0x4E
Data	0x2F(Note2)	SIO MB PnP Mode Data Register 0x2F or 0x4F

Table 2 : Digital Input relative register table					
	LDN	Register	BitNum	Value	Note
DIO-1 Pin Status	0x06(Note3)	0x8A(Note4)	0(Note5)		GPIO80
DIO-2 Pin Status	0x06(Note6)	0x8A(Note7)	1(Note8)		GPIO81
DIO-3 Pin Status	0x06(Note9)	0x8A(Note10)	2(Note11)		GPIO82
DIO-4 Pin Status	0x06(Note12)	0x8A(Note13)	3(Note14)		GPIO83
DIO-5 Pin Status	0x06(Note15)	0x8A(Note16)	4(Note17)		GPIO84
DIO-6 Pin Status	0x06(Note18)	0x8A(Note19)	5(Note20)		GPIO85
DIO-7 Pin Status	0x06(Note21)	0x8A(Note22)	6(Note23)		GPIO86
DIO-8 Pin Status	0x06(Note24)	0x8A(Note25)	7(Note26)		GPIO87

Table 3 : Digital Output relative register table					
	LDN	Register	BitNum	Value	Note
DIO-1 Output Data	0x06(Note27)	0x89(Note28)	0(Note29)	(Note30)	GPIO80
DIO-2 Output Data	0x06(Note31)	0x89(Note32)	1(Note33)	(Note34)	GPIO81
DIO-3 Output Data	0x06(Note35)	0x89(Note36)	2(Note37)	(Note38)	GPIO82
DIO-4 Output Data	0x06(Note39)	0x89(Note40)	3(Note41)	(Note42)	GPIO83
DIO-5 Output Data	0x06(Note43)	0x89(Note44)	4(Note45)	(Note46)	GPIO84
DIO-6 Output Data	0x06(Note47)	0x89(Note48)	5(Note49)	(Note50)	GPIO85
DIO-7 Output Data	0x06(Note51)	0x89(Note52)	6(Note53)	(Note54)	GPIO86
DIO-8 Output Data	0x06(Note55)	0x89(Note56)	7(Note57)	(Note58)	GPIO87

## D.3 Digital I/O Sample Program

---

```
*****
// SuperIO relative definition (Please reference to Table 1)
#define byte SIOIndex //This parameter is represented from Note1
#define byte SIOData //This parameter is represented from Note2
#define void IOWriteByte(byte IOPort, byte Value);
#define byte IOReadByte(byte IOPort);
// Digital Input Status relative definition (Please reference to Table 2)
#define byte DInput1LDN // This parameter is represented from Note3
#define byte DInput1Reg // This parameter is represented from Note4
#define byte DInput1Bit // This parameter is represented from Note5
#define byte DInput2LDN // This parameter is represented from Note6
#define byte DInput2Reg // This parameter is represented from Note7
#define byte DInput2Bit // This parameter is represented from Note8
#define byte DInput3LDN // This parameter is represented from Note9
#define byte DInput3Reg // This parameter is represented from Note10
#define byte DInput3Bit // This parameter is represented from Note11
#define byte DInput4LDN // This parameter is represented from Note12
#define byte DInput4Reg // This parameter is represented from Note13
#define byte DInput4Bit // This parameter is represented from Note14
#define byte DInput5LDN // This parameter is represented from Note15
#define byte DInput5Reg // This parameter is represented from Note16
#define byte DInput5Bit // This parameter is represented from Note17
#define byte DInput6LDN // This parameter is represented from Note18
#define byte DInput6Reg // This parameter is represented from Note19
#define byte DInput6Bit // This parameter is represented from Note20
#define byte DInput7LDN // This parameter is represented from Note21
#define byte DInput7Reg // This parameter is represented from Note22
#define byte DInput7Bit // This parameter is represented from Note23
#define byte DInput8LDN // This parameter is represented from Note24
#define byte DInput8Reg // This parameter is represented from Note25
#define byte DInput8Bit // This parameter is represented from Note26
*****
```

```

*****
// Digital Output control relative definition (Please reference to Table 3)
#define byte DOutput1LDN // This parameter is represented from Note27
#define byte DOutput1Reg // This parameter is represented from Note28
#define byte DOutput1Bit // This parameter is represented from Note29
#define byte DOutput1Val // This parameter is represented from Note30
#define byte DOutput2LDN // This parameter is represented from Note31
#define byte DOutput2Reg // This parameter is represented from Note32
#define byte DOutput2Bit // This parameter is represented from Note33
#define byte DOutput2Val // This parameter is represented from Note34
#define byte DOutput3LDN // This parameter is represented from Note35
#define byte DOutput3Reg // This parameter is represented from Note36
#define byte DOutput3Bit // This parameter is represented from Note37
#define byte DOutput3Val // This parameter is represented from Note38
#define byte DOutput4LDN // This parameter is represented from Note39
#define byte DOutput4Reg // This parameter is represented from Note40
#define byte DOutput4Bit // This parameter is represented from Note41
#define byte DOutput4Val // This parameter is represented from Note42
#define byte DOutput5LDN // This parameter is represented from Note43
#define byte DOutput5Reg // This parameter is represented from Note44
#define byte DOutput5Bit // This parameter is represented from Note45
#define byte DOutput5Val // This parameter is represented from Note46
#define byte DOutput6LDN // This parameter is represented from Note47
#define byte DOutput6Reg // This parameter is represented from Note48
#define byte DOutput6Bit // This parameter is represented from Note49
#define byte DOutput6Val // This parameter is represented from Note50
#define byte DOutput7LDN // This parameter is represented from Note51
#define byte DOutput7Reg // This parameter is represented from Note52
#define byte DOutput7Bit // This parameter is represented from Note53
#define byte DOutput7Val // This parameter is represented from Note54
#define byte DOutput8LDN // This parameter is represented from Note55
#define byte DOutput8Reg // This parameter is represented from Note56
#define byte DOutput8Bit // This parameter is represented from Note57
#define byte DOutput8Val // This parameter is represented from Note58
*****

```

```
*****
VOID Main(){
    Boolean PinStatus ;

    // Procedure : AaeonReadPinStatus
    // Input :
    //     Example, Read Digital I/O Pin 3 status
    // Output :
    //     InputStatus :
    //         0: Digital I/O Pin level is low
    //         1: Digital I/O Pin level is High
    PinStatus = AaeonReadPinStatus(DInput3LDN, DInput3Reg, DInput3Bit);

    // Procedure : AaeonSetOutputLevel
    // Input :
    //     Example, Set Digital I/O Pin 6 level
    AaeonSetOutputLevel(DOutput6LDN, DOutput6Reg, DOutput6Bit,
DOutput6Val);
}
*****
```



```
*****
Boolean  AaeonReadPinStatus(byte LDN, byte Register, byte BitNum){
    Boolean PinStatus ;

    PinStatus = SIOBitRead(LDN, Register, BitNum);
    Return PinStatus ;
}
VOID  AaeonSetOutputLevel(byte LDN, byte Register, byte BitNum, byte Value){
    ConfigToOutputMode(LDN, Register, BitNum);
    SIOBitSet(LDN, Register, BitNum, Value);
}
*****
```

```
*****
VOID  SIOEnterMBPnPMode(){
    IOWriteByte(SIOIndex, 0x87);
    IOWriteByte(SIOIndex, 0x87);
}

VOID  SIOExitMBPnPMode(){
    IOWriteByte(SIOIndex, 0xAA);
}

VOID  SIOSelectLDN(byte LDN){
    IOWriteByte(SIOIndex, 0x07); // SIO LDN Register Offset = 0x07
    IOWriteByte(SIOData, LDN);
}

VOID  SIOBitSet(byte LDN, byte Register, byte BitNum, byte Value){
    Byte TmpValue;

    SIOEnterMBPnPMode();
    SIOSelectLDN(byte LDN);
    IOWriteByte(SIOIndex, Register);
    TmpValue = IOReadByte(SIOData);
    TmpValue &= ~(1 << BitNum);
    TmpValue |= (Value << BitNum);
    IOWriteByte(SIOData, TmpValue);
    SIOExitMBPnPMode();
}

VOID  SIOByteSet(byte LDN, byte Register, byte Value){
    SIOEnterMBPnPMode();
    SIOSelectLDN(LDN);
    IOWriteByte(SIOIndex, Register);
    IOWriteByte(SIOData, Value);
    SIOExitMBPnPMode();
}
*****
```

```

*****
Boolean  SIOBitRead(byte LDN, byte Register, byte BitNum){
    Byte TmpValue;

    SIOEnterMBPnPMode();
    SIOSelectLDN(LDN);
    IOWriteByte(SIOIndex, Register);
    TmpValue = IOReadByte(SIOData);
    TmpValue &= (1 << BitNum);
    SIOExitMBPnPMode();
    If(TmpValue == 0)
        Return 0;
    Return 1;
}
VOID  ConfigToOutputMode(byte LDN, byte Register, byte BitNum){
    Byte TmpValue, OutputEnableReg;

    OutputEnableReg = Register-1;
    SIOEnterMBPnPMode();
    SIOSelectLDN(LDN);
    IOWriteByte(SIOIndex, OutputEnableReg);
    TmpValue = IOReadByte(SIOData);
    TmpValue |= (1 << BitNum);
    IOWriteByte(SIOData, OutputEnableReg);
    SIOExitMBPnPMode();
}
*****

```