

# BOXER-6842M

---

Fanless Embedded Box PC

User's Manual 4<sup>th</sup> Ed

## Copyright Notice

---

This document is copyrighted, 2021. All rights are reserved. The original manufacturer reserves the right to make improvements to the products described in this manual at any time without notice.

No part of this manual may be reproduced, copied, translated, or transmitted in any form or by any means without the prior written permission of the original manufacturer. Information provided in this manual is intended to be accurate and reliable. However, the original manufacturer assumes no responsibility for its use, or for any infringements upon the rights of third parties that may result from its use.

The material in this document is for product information only and is subject to change without notice. While reasonable efforts have been made in the preparation of this document to assure its accuracy, AAEON assumes no liabilities resulting from errors or omissions in this document, or from the use of the information contained herein.

AAEON reserves the right to make changes in the product design without notice to its users.

## Acknowledgements

---

All other products' name or trademarks are properties of their respective owners.

- Microsoft Windows® is a registered trademark of Microsoft Corp.
- Intel®, Pentium®, Celeron®, and Xeon® are registered trademarks of Intel Corporation
- Intel Core™ is a trademark of Intel Corporation
- ITE is a trademark of Integrated Technology Express, Inc.
- IBM, PC/AT, PS/2, and VGA are trademarks of International Business Machines Corporation.
- Ubuntu is a registered trademark of Canonical
- NVIDIA® and Tesla® are registered trademarks of NVIDIA Corporation

All other product names or trademarks are properties of their respective owners. No ownership is assumed or implied by the publisher of this document for products or product names not herein included.

## Packing List

---

Before setting up your product, please make sure the following items have been shipped:

Item	Quantity
BOXER-6842M	1

---

If any of these items are missing or damaged, please contact your distributor or sales representative immediately.

## About this Document

---

This User's Manual contains all the essential information, such as detailed descriptions and explanations on the product's hardware and software features (if any), its specifications, dimensions, jumper/connector settings/definitions, and driver installation instructions (if any), to facilitate users in setting up their product.

Users may refer to the product page on [AAEON.com](http://AAEON.com) for the latest version of this document.

## Safety Precautions

---

Please read the following safety instructions carefully. It is advised that you keep this manual for future references

1. All cautions and warnings on the device should be noted.
2. Make sure the power source matches the power rating of the device.
3. Position the power cord so that people cannot step on it. Do not place anything over the power cord.
4. Always completely disconnect the power before working on the system's hardware.
5. No connections should be made when the system is powered as a sudden rush of power may damage sensitive electronic components.
6. If the device is not to be used for a long time, disconnect it from the power supply to avoid damage by transient over-voltage.
7. Always disconnect this device from any power supply before cleaning.
8. While cleaning, use a damp cloth instead of liquid or spray detergents.
9. Make sure the device is installed near a power outlet and is easily accessible.
10. Keep this device away from humidity.
11. Place the device on a solid surface during installation to prevent falls.
12. Do not cover the openings on the device to ensure optimal heat dissipation.
13. Watch out for high temperatures when the system is running.
14. Do not touch the heat sink or heat spreader when the system is running
15. Never pour any liquid into the openings. This could cause fire or electric shock.
16. As most electronic components are sensitive to static electrical charge, be sure to ground yourself to prevent static charge when installing the internal components. Use a grounding wrist strap and contain all electronic components in any static-shielded containers.

17. If any of the following situations arises, please contact our service personnel:
  - i. Damaged power cord or plug
  - ii. Liquid intrusion to the device
  - iii. Exposure to moisture
  - iv. Device is not working as expected or in a manner as described in this manual
  - v. The device is dropped or damaged
  - vi. Any obvious signs of damage displayed on the device
18. Do not leave this device in an uncontrolled environment with temperatures beyond the device's permitted storage temperatures (see chapter 1) to prevent damage.
19. Do NOT disassemble the motherboard so as not to damage the system or void your warranty.
20. If the thermal pad had been damaged, please contact AAEON's salesperson to purchase a new one. Do NOT use those of other brands.
21. The Hex Cylinder Coppers on the front panel are not removable.
22. Repeatedly assemble and disassemble the system may cause damages to the exterior paint and surface and screw holes.
23. Use the right size screwdriver.
24. Use the screwdriver correctly to remove screws from the system.

## FCC Statement

---

### **Warning!**



This device complies with Part 15 FCC Rules. Operation is subject to the following two conditions: (1) this device may not cause harmful interference, and (2) this device must accept any interference received including interference that may cause undesired operation.

### **Caution:**

*There is a danger of explosion if the battery is incorrectly replaced. Replace only with the same or equivalent type recommended by the manufacturer. Dispose of used batteries according to the manufacturer's instructions and your local government's recycling or disposal directives.*

### **Attention:**

*Il y a un risque d'explosion si la batterie est remplacée de façon incorrecte. Ne la remplacer qu'avec le même modèle ou équivalent recommandé par le constructeur. Recycler les batteries usées en accord avec les instructions du fabricant et les directives gouvernementales de recyclage.*

## 产品中有毒有害物质或元素名称及含量

AAEON System

QO4-381 Rev.A0

部件名称	有毒有害物质或元素					
	铅 (Pb)	汞 (Hg)	镉 (Cd)	六价铬 (Cr(VI))	多溴联苯 (PBB)	多溴二苯醚 (PBDE)
印刷电路板 及其电子组件	×	○	○	○	○	○
外部信号 连接器及线材	×	○	○	○	○	○
外壳	○	○	○	○	○	○
中央处理器 与内存	×	○	○	○	○	○
硬盘	×	○	○	○	○	○
液晶模块	×	×	○	○	○	○
光驱	×	○	○	○	○	○
触控模块	×	○	○	○	○	○
电源	×	○	○	○	○	○
电池	×	○	○	○	○	○

本表格依据 SJ/T 11364 的规定编制。

○：表示该有毒有害物质在该部件所有均质材料中的含量均在 GB/T 26572标准规定的限量要求以下。

×：表示该有害物质的某一均质材料超出了GB/T 26572的限量要求，然而该部件仍符合欧盟指令2011/65/EU 的规范。

备注：

一、此产品所标示之环保使用期限，系指在一般正常使用状况下。

二、上述部件物质中央处理器、内存、硬盘、光驱、电源为选购品。

三、上述部件物质液晶模块、触控模块仅一体机产品适用。

# China RoHS Requirement (EN)

## Hazardous and Toxic Materials List

AAEON System

QO4-381 Rev.A0

Component Name	Hazardous or Toxic Materials or Elements					
	Lead (Pb)	Mercury (Hg)	Cadmium (Cd)	Hexavalent Chromium (Cr(VI))	Polybrominated biphenyls (PBBs)	Polybrominated diphenyl ethers (PBDEs)
PCB and Components	X	O	O	O	O	O
Wires & Connectors for Ext. Connections	X	O	O	O	O	O
Chassis	O	O	O	O	O	O
CPU & RAM	X	O	O	O	O	O
HDD Drive	X	O	O	O	O	O
LCD Module	X	X	O	O	O	O
Optical Drive	X	O	O	O	O	O
Touch Control Module	X	O	O	O	O	O
PSU	X	O	O	O	O	O
Battery	X	O	O	O	O	O

This form is prepared in compliance with the provisions of SJ/T 11364.

O: The level of toxic or hazardous materials present in this component and its parts is below the limit specified by GB/T 26572.

X: The level of toxic or hazardous materials present in the component exceed the limits specified by GB/T 26572, but is still in compliance with EU Directive 2011/65/EU (RoHS 2).

**Notes:**

1. The Environment Friendly Use Period indicated by labelling on this product is applicable only to use under normal conditions.
2. Individual components including the CPU, RAM/memory, HDD, optical drive, and PSU are optional.
3. LCD Module and Touch Control Module only applies to certain products which feature these components.

# Table of Contents

---

<b>Chapter 1 - Product Specifications</b> .....	<b>1</b>
1.1 Specifications .....	2
<b>Chapter 2 – Hardware Information</b> .....	<b>6</b>
2.1 Dimensions .....	7
2.1.1 A2 & A3 System.....	7
2.1.2 A4 System.....	8
2.1.3 A5 System.....	9
2.1.4 Main Board .....	10
2.2 Jumpers and Connectors.....	11
2.3 List of Jumpers.....	12
2.3.1 PCIe [x16] Bifurcation Selection (JP1, JP2).....	12
2.3.2 Clear CMOS Jumper (JP3).....	13
2.3.3 PCIe, SATA Selection for M.2 Slot (JP4) .....	13
2.3.4 PCIe, SATA Selection for Mini-Card Slot (JP5) .....	13
2.3.5 PCIe [x16] Lanes Normal/Reversed (JP11) .....	13
2.3.6 Auto Power Button Selection (JP20) .....	13
2.4 List of Connectors .....	14
2.4.1 PCIe [x4] Slot (CN5).....	16
2.4.2 Audio I/O Port (10P Pitch: 1.25mm) (CN7) .....	19
2.4.3 Dual HDMI Port (CN8).....	19
2.4.4 LAN (RJ-45) + Dual USB 3.0 (CN9).....	20
2.4.5 LAN (RJ-45) + Dual USB 3.0 (CN10) .....	22
2.4.6 LAN (RJ-45) + Dual USB 3.0 (CN11).....	24
2.4.7 CPU FAN Connector (CN12).....	26
2.4.8 System FAN Connector (CN13) .....	26
2.4.9 M.2 Connector (CN14) .....	27

2.4.10	Remote Button Connector (CN16).....	30
2.4.11	PS_ON Connector .....	30
2.4.12	SPI Flash Port (CN18).....	30
2.4.13	LPC Connector (CN19) .....	31
2.4.14	SATA Connector (CN20, CN23, CN24, CN26).....	32
2.4.15	SATA Power Connector (CN21, CN22, CN25, CN27) .....	32
2.4.16	Digital IO Port (CN28) .....	33
2.4.17	COM1, COM2 Connector (RS232/RS422/RS485) (CN29).....	34
2.4.18	COM Port 1 Wafer Box (Optional) (CN30).....	35
2.4.19	COM Port 2 Wafer Box (Optional) (CN31).....	36
2.4.20	COM3, COM4 Connector (RS232/RS422/RS485) (CN32) .....	37
2.4.21	COM Port 3 Wafer Box (Optional) (CN33) .....	38
2.4.22	COM Port 4 Wafer Box (Optional) (CN34).....	39
2.4.23	COM Port 5 Wafer Box (Optional) (CN35) .....	40
2.4.24	COM Port 6 Wafer Box (Optional) (CN36).....	41
2.4.25	Mini-Card Slot (Full-Sized) (CN37) .....	42
2.4.26	SIM Slot (CN38) .....	44
2.4.27	Mini-Card Slot (Half-Sized) (CN39) .....	45
2.4.28	USB 2.0 Wafer Box (CN40, CN41, CN42, CN43) .....	47
2.4.29	Audio Jack Connector (CN44) .....	48
2.4.30	Audio Connector Wafer Box (CN45) .....	49
2.4.31	DC-IN Connector (CN48).....	50
2.4.32	GPU DC-IN Connector (CN50, CN51) .....	51
2.4.33	RTC Battery Connector (BAT1) .....	51
2.5	CPU Installation .....	52
2.6	DDR4 Memory Module Installation .....	53
2.7	2.5" SATA Drive Installation .....	55
2.8	Graphics Card Installation .....	57

2.9	Connecting System Power .....	61
<b>Chapter 3 - AMI BIOS Setup .....</b>		<b>63</b>
3.1	System Test and Initialization .....	64
3.2	AMI BIOS Setup .....	65
3.3	Main – Setup Submenu .....	66
3.4	Advanced – Setup Submenu .....	67
3.4.1	Advanced: Trusted Computing .....	68
3.4.2	Advanced: CPU Configuration .....	70
3.4.3	Advanced: PCH-FW Configuration .....	72
3.4.3.1	Firmware Update Configuration .....	73
3.4.3.2	PTT Configuration .....	74
3.4.4	Advanced: SATA Configuration .....	75
3.4.5	Advanced: USB Configuration .....	76
3.4.6	Advanced: Hardware Monitor .....	77
3.4.6.1	Smart Fan Mode Configuration .....	78
3.4.7	Advanced: SIO Configuration .....	80
3.4.7.1	Serial Port 1 .....	81
3.4.7.2	Serial Port 2 .....	82
3.4.7.3	Serial Port 3 .....	83
3.4.7.4	Serial Port 4 .....	84
3.4.7.5	Serial Port 5 .....	85
3.4.7.6	Serial Port 6 .....	86
3.4.8	Advanced: Network Stack Configuration .....	87
3.4.9	Advanced: Digital IO Port Configuration .....	89
3.4.10	Advanced: Power Management .....	90
3.5	Chipset – Setup Submenu .....	92
3.5.1	Chipset: System Agent (SA) Configuration .....	93
3.5.2	Chipset: PEG Port Configuration .....	95

3.5.3	Chipset: PCH-IO Configuration .....	96
3.6	Security – Setup Submenu .....	97
3.6.1	Security: Secure Boot .....	98
3.6.1.1	Key Management .....	99
3.7	Boot – Setup Submenu.....	102
3.8	Save & Exit – Setup Submenu .....	103
<b>Chapter 4 – Drivers Installation .....</b>		<b>104</b>
4.1	Drivers Download and Installation .....	105
<b>Appendix A - I/O Information.....</b>		<b>107</b>
A.1	I/O Address Map.....	108
A.2	Memory Address Map.....	110
A.3	IRQ Mapping Chart.....	111
<b>Appendix B – Glue Removal Procedure.....</b>		<b>112</b>
B.1	Removing Glue from Your System .....	113

# Chapter 1

---

Product Specifications

## 1.1 Specifications

---

### System

<b>CPU</b>	Intel® Xeon® E-2124G Intel® Core™ i9-9900T Intel® Core™ i7-8700T Intel® Core™ i5-8500T Intel® Core™ i3-8100T Intel® Pentium® G5400T Intel® Celeron® G4900T Support max. TPD 71W Processor
<b>Chipset</b>	C246, No H310 downward support
<b>System Memory</b>	DDR4 SO-DIMM socket x4 (double deck) Support max. 2666MHz up to 128GB Support un-buffered and ECC / non-ECC type SODIMM
<b>Display Interface</b>	HDMI x 2 Supports dual independent displays, 4K Ultra HD
<b>Storage Device</b>	2.5" SATA Drive Bay x 2 (four SATA Ports w/ RAID Function) mSATA x 1 (optional) M.2 2280 NVMe SSD slot x 1
<b>Ethernet</b>	RJ-45 x 3 for GbE (Intel i211AT x 2, i219LM x 1)
<b>I/O</b>	HDMI x 2 Audio (Mic-in, Line-out) USB3.2 Gen1 x 6 DB-9 x4 for RS-232/422/485 with automatic flow control 3 pin DC Power input x 1 (+, -, GND) Power ON/OFF switch x 1 2 pin Remote power on/off connector Reset switch

## System

### Expansion

#### **A2/A3/A4/A5 Models:**

Full-size Mini Card x 1 (PCIe + USB with 1 SIM Slot)

Half-size Mini Card x 1 (PCIe + USB, option for mSATA)

M.2 M key (2280) x 1 (PCIe [x4])

**PCIe Card:** Max Power Consumption Supported is 250W.

Max Card Size supported is 280mm x 150mm x 40mm

**A2 Model:** PCIe [x4] x 1 + PCIe [x16] x 1

**A3 Model:** PCIe [x4] x 1 + PCIe [x8] (in [x16] slot) x 2

**A4 Model:** PCIe [x4] x 1 + PCIe [x8] (in [x16] slot) x 2; supports dual graphics cards with two power inputs

#### **A5 Model:**

Built in NVIDIA Tesla T4 x 1

PCIe [x4] x 1 + PCIe [x8] x 1 (in [x16] slot)

**Note:** A3 is a fan-less system.

A2, A4, and A5 are cooled by system fan with PWM function.

### Reserved Connector

Internal, SATA x 2

Internal, 8bit DIO x 1

Internal, USB 2.0 x 4

Internal, LPC x 1

Internal, Secondary System Fan Connector x 1

### Indicator

System Power LED x 1 (Green)

Storage Active LED x 1 (Red)

### OS Support

Windows® 10 Enterprise 64 bit

Ubuntu 18.04.4

## Power Supply

### Power Requirement

#### A2/A3/A4 Models

DC In 12~24V with 3-pin terminal block

*No Graphics Card:*

CPU  $\leq$ 35W TDP, use 120W Adapter x 1

CPU  $\leq$ 71W TDP, use 240W Adapter x 1

*With 250W Graphics Card x1:*

480W Adapter x 1

#### A4 Model

DC In 12~24V with 3-pin terminal block

With 250W Graphics Card x2:

330W Adapter x 1 + 480W Adapter x 1

#### A5 Model

DC In 12~24V with 3-pin terminal block

With T4 x 1: 240W Power Adapter x 1

With T4 x 2: 330W Power Adapter x 1

## Mechanical

### Mounting

Wall mount

### Dimensions (W x H x D)

#### A2/A3/A5 Models:

6.17" x 8.92" x 12.8" (156.7mm x 226.5mm x 325mm)

#### A4 Model:

7.77" x 8.92" x 12.8" (197.3mm x 226.5mm x 325mm)

### Gross Weight

**A2/A3 Models:** 18.52 lbs. (8.4 kg)

**A4 Model:** 20.72 lbs. (9.4 kg)

**A5 Model:** 20.5 lbs. (9.3 kg)

### Net Weight

**A2/A3 Models:** 15.65 lbs. (7.1 kg)

**A4 Model:** 17.86 lbs. (8.1 kg)

**A5 Model:** 17.64 lbs. (8 kg)

## Environmental

<b>Operating Temperature</b>	<i>Without Graphics Card:</i> -4°F ~ 149°F (-20°C ~ 65°C) with 0.5m/s airflow <i>With 250W Graphics Card:</i> 32°F ~ 113°F (0°C ~ 45°C) with 0.5m/s airflow <b>A5 Model:</b> 32°F ~ 113°F (0°C ~ 40°C) with 0.5m/s airflow
<b>Storage Temperature</b>	-49°F ~ 176°F (-45°C ~ 80°C)
<b>Storage Humidity</b>	5 ~ 95% @ 40°C, non-condensing
<b>Anti-Vibration</b>	HDD: Random, 1Grm, 5~500Hz
<b>Certification</b>	CE / FCC class A

# Chapter 2

---

Hardware Information

## 2.1 Dimensions

### 2.1.1 A2 & A3 System

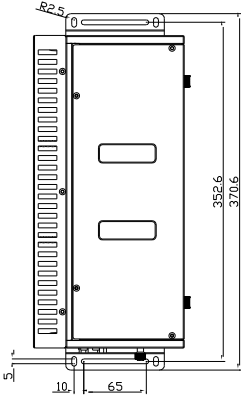

Unit:mm

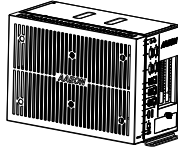

SCALE 1:2

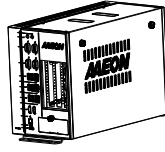

SCALE 1:2

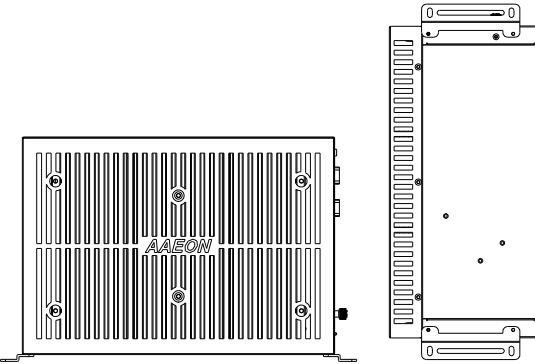
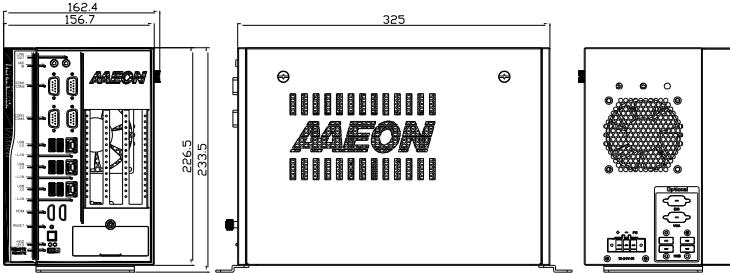

## 2.1.2 A4 System

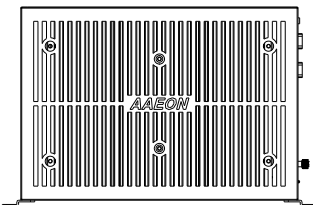
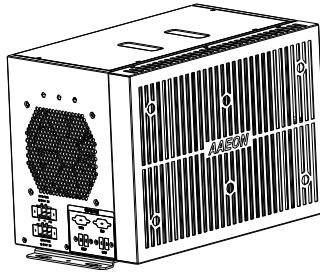
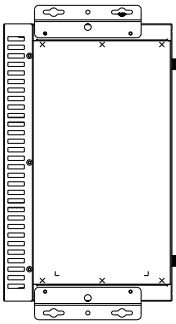
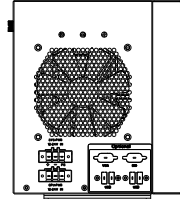
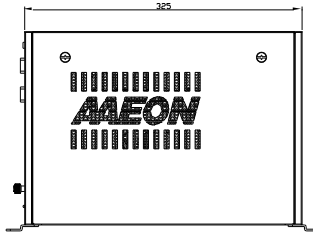
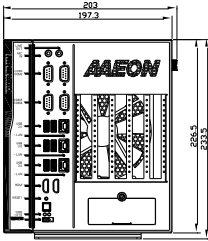
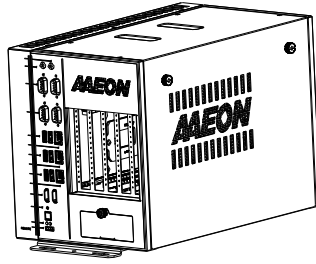
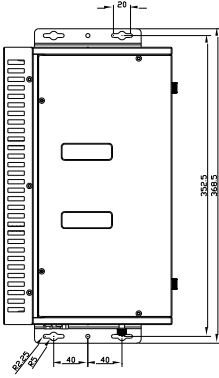

## 2.1.3 A5 System

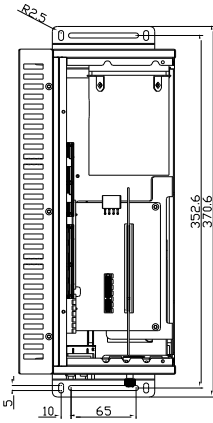

Unit:mm

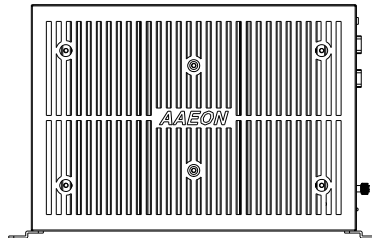
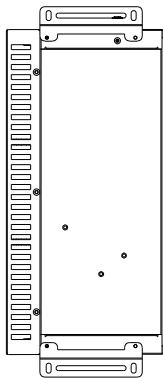
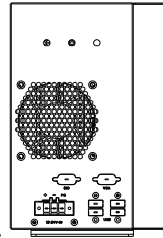
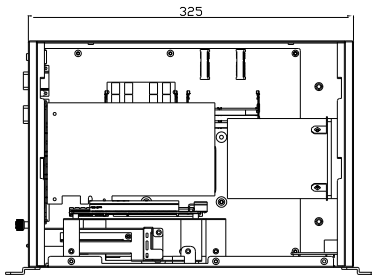
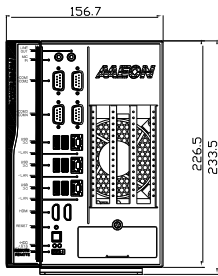
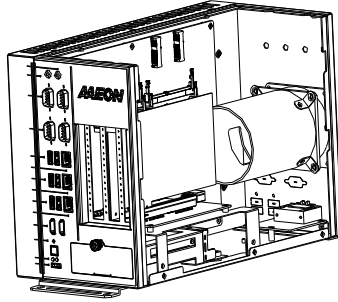

## 2.1.4 Main Board

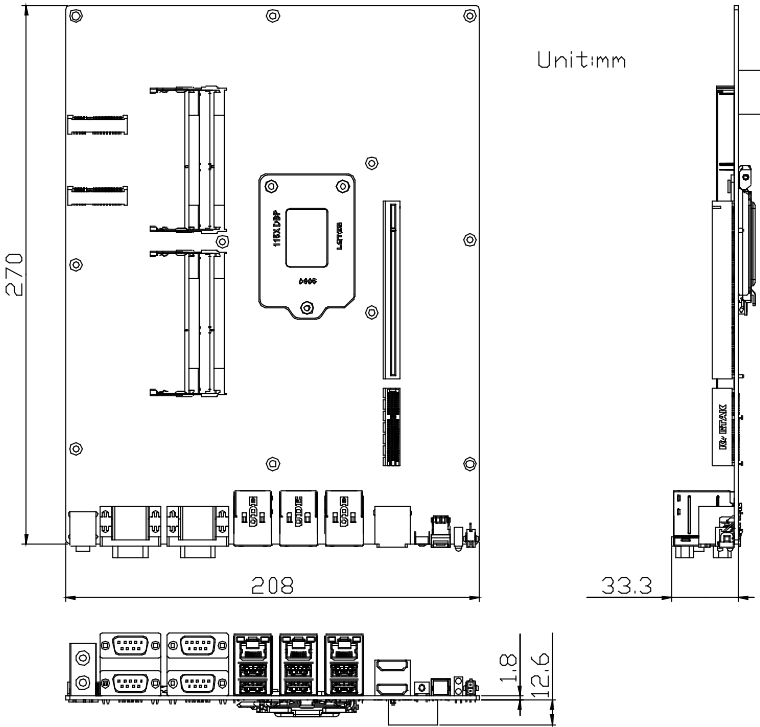

## 2.2 Jumpers and Connectors

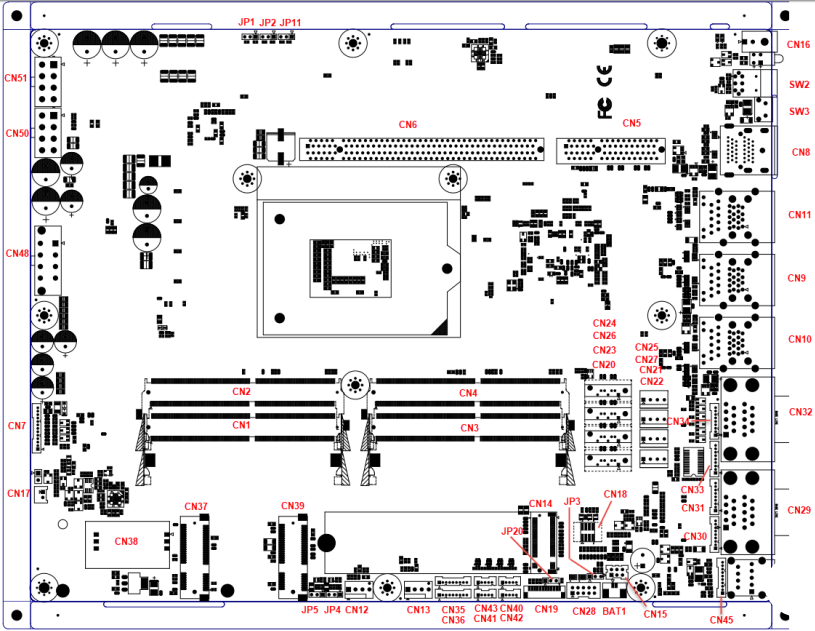

## 2.3 List of Jumpers

Please refer to the table below for all of the system's jumpers that you can configure for your application.

Label	Function
JP1, JP2	PCIe [x16] Bifurcation selection
JP3	CMOS Control Selection
JP4	PCIe and SATA bus selection for M.2 slot
JP5	PCIe and SATA bus selection for Mini-Card slot
JP11	PCIe [x16] lane normal/reversed selection
JP20	Auto-Power Button Selection

### 2.3.1 PCIe [x16] Bifurcation Selection (JP1, JP2)

To set bifurcation selection, you must set jumpers on both JP1 and JP2 according to this chart.

Setting	JP1	JP2
PCIe [x16] x 1 (Default)	1 2 3 	1 2 3 
PCIe [x8] x 2	1 2 3 	1 2 3 
PCIe [x8] x 1 and PCIe [x4] x 2	1 2 3 	1 2 3 
Reserved	1 2 3 	1 2 3 

### 2.3.2 Clear CMOS Jumper (JP3)

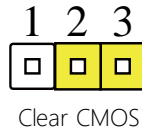
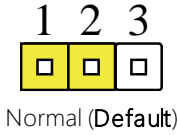

### 2.3.3 PCIe, SATA Selection for M.2 Slot (JP4)

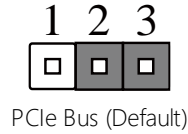
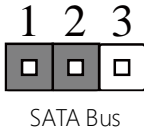

### 2.3.4 PCIe, SATA Selection for Mini-Card Slot (JP5)

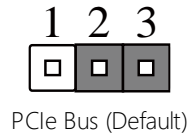
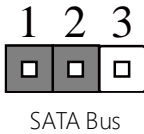

### 2.3.5 PCIe [x16] Lanes Normal/Reversed (JP11)

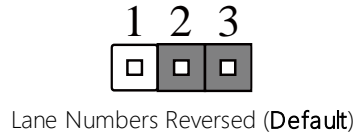
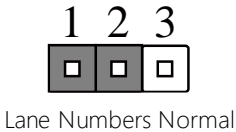

### 2.3.6 Auto Power Button Selection (JP20)

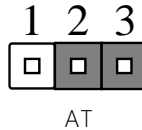
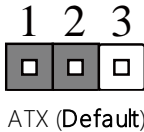

## 2.4 List of Connectors

Please refer to the table below for all of the system's connectors that you can configure for your application

Label	Function
CN1	SO-DIMM Channel A0
CN2	SO-DIMM Channel A1
CN3	SO-DIMM Channel B0
CN4	SO-DIMM Channel B1
CN5	PCIe [x4] slot
CN6	PCIe [x16] slot
CN7	VGA box connector
CN8	Dual HDMI port
CN9	LAN (RJ-45) + Dual USB 3.0 Connector
CN10	LAN (RJ-45) + Dual USB 3.0 Connector
CN11	LAN (RJ-45) + Dual USB 3.0 Connector
CN12	CPU FAN connector
CN13	System FAN connector
CN14	M.2 slot connector (2280)
CN15	PS/2 Connector
CN16	Remote button connector
CN17	PS_ON Connector
CN18	SPI ROM connector
CN19	LPC bus connector
CN20	SATA connector
CN21	SATA PWR connector
CN22	SATA PWR connector
CN23	SATA connector
CN24	SATA connector

Label	Function
CN25	SATA PWR connector
CN26	SATA connector
CN27	SATA PWR connector
CN28	DIO box connector
CN29	COM1+COM2 Connector RS232/RS422/RS485
CN30	COM1 HEADER RS232/RS422/RS485
CN31	COM2 HEADER RS232/RS422/RS485
CN32	COM3+COM4 Connector RS232/RS422/RS485
CN33	COM3 HEADER RS232/RS422/RS485
CN34	COM4 HEADER RS232/RS422/RS485
CN35	COM5 HEADER RS232/RS422/RS485
CN36	COM6 HEADER RS232/RS422/RS485
CN37	Mini-PCIe slot (Full Size)
CN38	SIM card slot
CN39	Mini-PCIe slot (Half Size)
CN40	USB 2.0 box connector
CN41	USB 2.0 box connector
CN42	USB 2.0 box connector
CN43	USB 2.0 box connector
CN44	Audio connector
CN45	Audio box connector
CN48	Power input connector for system
CN50	Power input connector for GPU
CN51	Power input connector for GPU
SW2	Power button with LED
SW3	Release button
BAT1	RTC Battery Connector

## 2.4.1 PCIe [x4] Slot (CN5)

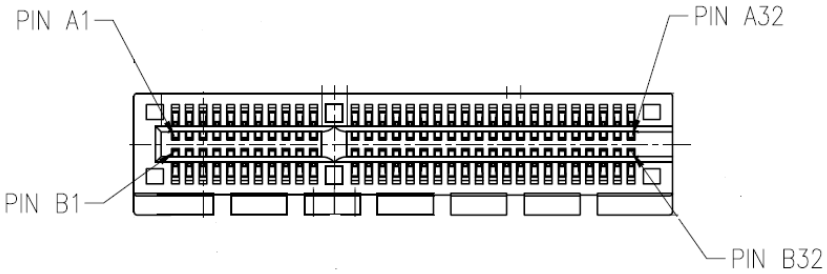

Pin	Pin name	Signal Type	Signal Level
A1	PRSNT1#	I/O	
A2	+12V	PWR	+V12S
A3	+12V	PWR	+V12S
A4	GND	GND	
A5	PCIE_TXN5	DIFF	
A6	PCIE_TXP5	DIFF	
A7	PCIE_RXN5	DIFF	
A8	PCIE_RXP5	DIFF	
A9	+3.3V	PWR	+V3.3S
A10	+3.3V	PWR	+V3.3S
A11	PERST#	I/O	
A12	GND	GND	
A13	PCIE_x4SLOT_CLK	DIFF	
A14	PCIE_x4SLOT_CLK#	DIFF	
A15	GND	GND	
A16	PCIE_RXP24	DIFF	
A17	PCIE_RXN24	DIFF	
A18	GND	GND	
A19	NC		

Pin	Pin name	Signal Type	Signal Level
A20	GND	GND	
A21	PCIE_RXP23	DIFF	
A22	PCIE_RXN23	DIFF	
A23	GND	GND	
A24	GND	GND	
A25	PCIE_RXP22	DIFF	
A26	PCIE_RXP22	DIFF	
A27	GND	GND	
A28	GND	GND	
A29	PCIE_RXP21	DIFF	
A30	PCIE_RXN21	DIFF	
A31	GND	GND	
A32	NC		
B1	+12V	PWR	+V12S
B2	+12V	PWR	+V12S
B3	+12V	PWR	+V12S
B4	GND	GND	
B5	SMB_CLK	I/O	
B6	SMB_DATA	I/O	
B7	GND	GND	
B8	+V3.3S	PWR	+V3.3S
B9	NC		
B10	3.3Vaux	PWR	+V3.3A
B11	WAKE#	I/O	
B12	NC		
B13	GND	GND	
B14	PCIE_TXP24	DIFF	

Pin	Pin name	Signal Type	Signal Level
B15	PCIE_TXN24	DIFF	
B16	GND	GND	
B17	PRSNT	I/O	
B18	GND	GND	
B19	PCIE_TXP23	DIFF	
B20	PCIE_TXN23	DIFF	
B21	GND	GND	
B22	GND	GND	
B23	PCIE_TXP22	DIFF	
B24	PCIE_TXN22	DIFF	
B25	GND	GND	
B26	GND	GND	
B27	PCIE_TXP21	DIFF	
B28	PCIE_TXN21	DIFF	
B29	GND	GND	
B30	NC		
B31	PRSNT	I/O	
B32	GND	GND	

## 2.4.2 Audio I/O Port (10P Pitch: 1.25mm) (CN7)

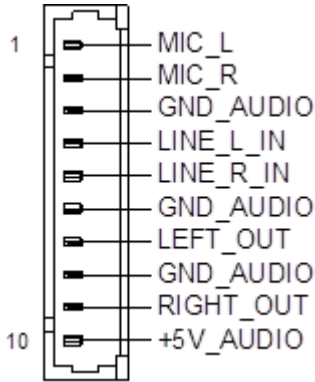

Pin	Pin name	Signal Type	Signal Level
1	MIC_L	IN	
2	MIC_R	IN	
3	GND_AUDIO	GND	
4	LINE_L_IN	IN	
5	LINE_R_IN	IN	
6	GND_AUDIO	GND	
7	LEFT_OUT	OUT	
8	GND_AUDIO	GND	
9	RIGHT_OUT	OUT	
10	+5V_AUDIO	PWR	+5V

## 2.4.3 Dual HDMI Port (CN8)

Standard Specification

## 2.4.4 LAN (RJ-45) + Dual USB 3.0 (CN9)

**Note:** Dual USB 3.0 ports are USB 3.2 Gen 2 (10 Gbps) specification.

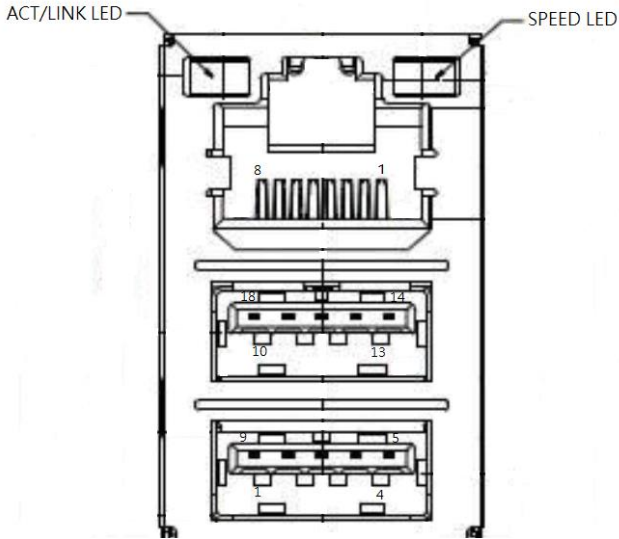

LAN (RJ-45)

Pin	Pin name	Signal Type	Signal Level
1	MDI0+	DIFF	
2	MDI0-	DIFF	
3	MDI1+	DIFF	
4	MDI2+	DIFF	
5	MDI2-	DIFF	
6	MDI1-	DIFF	
7	MDI3+	DIFF	
8	MDI3-	DIFF	

Dual USB 3.0 (USB 3.2 Gen 2)			
Pin	Pin name	Signal Type	Signal Level
1	+5VSB	PWR	+5V
2	USB1_D-	DIFF	
3	USB1_D+	DIFF	
4	GND	GND	
5	USB1_SSRX-	DIFF	
6	USB1_SSRX+	DIFF	
7	GND	GND	
8	USB1_SSTX-	DIFF	
9	USB1_SSTX+	DIFF	
10	+5VSB	PWR	+5V
11	USB2_D-	DIFF	
12	USB2_D+	DIFF	
13	GND	GND	
14	USB2_SSRX-	DIFF	
15	USB2_SSRX+	DIFF	
16	GND	GND	
17	USB2_SSTX-	DIFF	
18	USB2_SSTX+	DIFF	

## 2.4.5 LAN (RJ-45) + Dual USB 3.0 (CN10)

**Note:** Dual USB 3.0 ports are USB 3.2 Gen 2 (10 Gbps) specification.

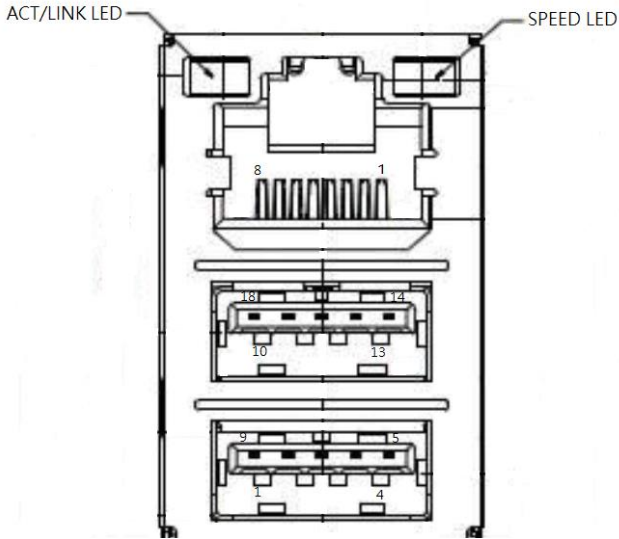

LAN (RJ-45)

Pin	Pin name	Signal Type	Signal Level
1	MDI0+	DIFF	
2	MDI0-	DIFF	
3	MDI1+	DIFF	
4	MDI2+	DIFF	
5	MDI2-	DIFF	
6	MDI1-	DIFF	
7	MDI3+	DIFF	
8	MDI3-	DIFF	

Dual USB 3.0 (USB 3.2 Gen 2)			
Pin	Pin name	Signal Type	Signal Level
1	+5VSB	PWR	+5V
2	USB3_D-	DIFF	
3	USB3_D+	DIFF	
4	GND	GND	
5	USB3_SSRX-	DIFF	
6	USB3_SSRX+	DIFF	
7	GND	GND	
8	USB3_SSTX-	DIFF	
9	USB3_SSTX+	DIFF	
10	+5VSB	PWR	+5V
11	USB4_D-	DIFF	
12	USB4_D+	DIFF	
13	GND	GND	
14	USB4_SSRX-	DIFF	
15	USB4_SSRX+	DIFF	
16	GND	GND	
17	USB4_SSTX-	DIFF	
18	USB4_SSTX+	DIFF	

## 2.4.6 LAN (RJ-45) + Dual USB 3.0 (CN11)

**Note:** Dual USB 3.0 ports are USB 3.2 Gen 2 (10 Gbps) specification.

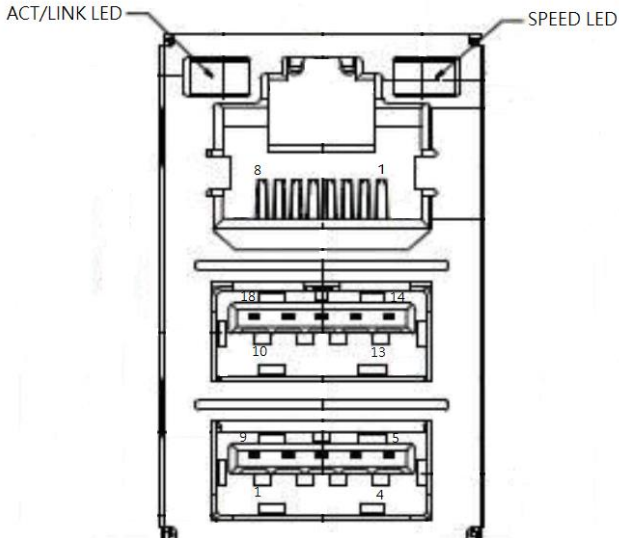

LAN (RJ-45)

Pin	Pin name	Signal Type	Signal Level
1	MDI0+	DIFF	
2	MDI0-	DIFF	
3	MDI1+	DIFF	
4	MDI2+	DIFF	
5	MDI2-	DIFF	
6	MDI1-	DIFF	
7	MDI3+	DIFF	
8	MDI3-	DIFF	

Dual USB 3.0 (USB 3.2 Gen 2)			
Pin	Pin name	Signal Type	Signal Level
1	+5VSB	PWR	+5V
2	USB5_D-	DIFF	
3	USB5_D+	DIFF	
4	GND	GND	
5	USB5_SSRX-	DIFF	
6	USB5_SSRX+	DIFF	
7	GND	GND	
8	USB5_SSTX-	DIFF	
9	USB5_SSTX+	DIFF	
10	+5VSB	PWR	+5V
11	USB6_D-	DIFF	
12	USB6_D+	DIFF	
13	GND	GND	
14	USB6_SSRX-	DIFF	
15	USB6_SSRX+	DIFF	
16	GND	GND	
17	USB6_SSTX-	DIFF	
18	USB6_SSTX+	DIFF	

## 2.4.7 CPU FAN Connector (CN12)

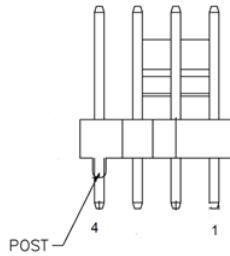

Pin	Pin name	Signal Type	Signal Level
1	GND	GND	
2	+VCC_FAN_CPU_CON	PWR	12V
3	FAN_TAC_CPU_CON	IN	
4	FAN_CTL_CPU_CON	OUT	

## 2.4.8 System FAN Connector (CN13)

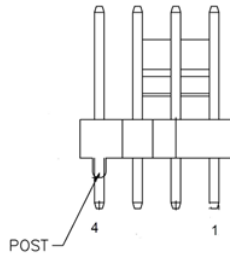

Pin	Pin name	Signal Type	Signal Level
1	GND	GND	
2	+VCC_FAN_CPU_CON	PWR	12V
3	FANIN2	IN	
4	FANCTL2	OUT	

## 2.4.9 M.2 Connector (CN14)

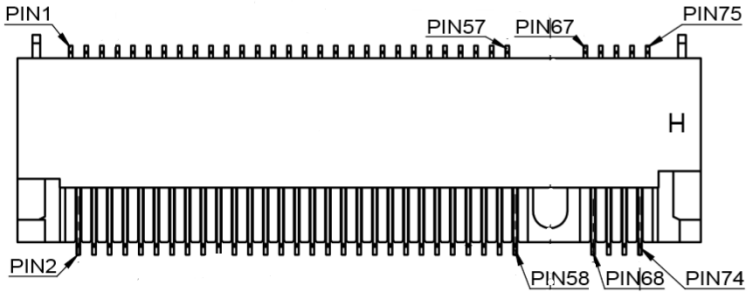

Pin	Pin name	Signal Type	Signal Level
Top (Odd)			
1	GND	GND	
3	GND	GND	
5	PCIE_RXN16	IN	
7	PCIE_RXP16	IN	
9	GND	GND	
11	PCIE_TXN16	OUT	
13	PCIE_TXP16	OUT	
15	GND	PWR	
17	PCIE_RXN15	IN	
19	PCIE_RXP15	IN	
21	GND	PWR	
23	PCIE_TXN15	OUT	
25	PCIE_TXP15	OUT	
27	GND	PWR	
29	PCIE_RXN14	IN	
31	PCIE_RXP14	IN	
33	GND	GND	
35	PCIE_TXN14	OUT	

Pin	Pin name	Signal Type	Signal Level
37	PCIE_TXP14	OUT	
39	GND	GND	
41	PCIE_RXP13/SATA0A_RXP	IN	
43	PCIE_RXN13/SATA0A_RXN	IN	
45	GND	GND	
47	PCIE_TXN13/SATA0A_TXN	OUT	
49	PCIE_TXP13/SATA0A_TXP	OUT	
51	GND	PWR	
53	PCIE_M.2_CLK#	OUT	
55	PCIE_M.2_CLK	OUT	
57	GND	GND	
67	NC		
69	M.2_SATA_PCIE_DET_C	OUT	
71	GND	GND	
73	GND	GND	
75	GND	GND	
<b>Bottom (Even)</b>			
2	+3.3V	PWR	+3.3V
4	+3.3V	PWR	+3.3V
6	NC		
8	NC		
10	NC		
12	+3.3V	PWR	+3.3V
14	+3.3V	PWR	+3.3V
16	+3.3V	PWR	+3.3V
18	+3.3V	PWR	+3.3V

Pin	Pin name	Signal Type	Signal Level
20	NC		
22	NC		
24	NC		
26	NC		
28	NC		
30	NC		
32	NC		
34	NC		
36	NC		
38	DEVSLP	IN	
40	NC		
42	NC		
44	NC		
46	NC		
48	NC		
50	RESET#	IN	
52	CLKREQ#	OUT	
54	WAKE#	OUT	
56	NC		
58	NC		
68	NC		
70	+3.3V	PWR	+3.3V
72	+3.3V	PWR	+3.3V
74	+3.3V	PWR	+3.3V

### 2.4.10 Remote Button Connector (CN16)

Pin	Pin name	Signal Type	Signal Level
1	PWR_BUTTON	IN	
3	GND	GND	

### 2.4.11 PS\_ON Connector

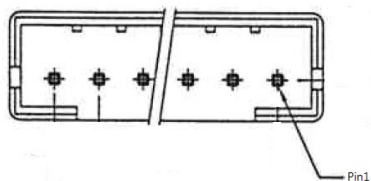

Pin	Pin Name	Signal Type	Signal Level
1	PS_ON	OUT	
2	GND	GND	

### 2.4.12 SPI Flash Port (CN18)

Pin	Pin Name	Signal Type	Signal Level
1	SPI_MISO	OUT	
2	GND	GND	
3	SPI_CLK	IN	
4	+3.3VSB	PWR	+3.3V
5	SPI_MOSI	IN	
6	SPI_CS	IN	
7	NC		
8	NC		

## 2.4.13 LPC Connector (CN19)

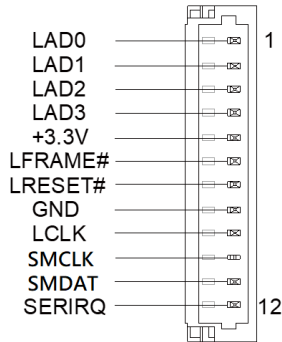

Pin	Pin name	Signal Type	Signal Level
1	LAD0	I/O	+3.3V
2	LAD1	I/O	+3.3V
3	LAD2	I/O	+3.3V
4	LAD3	I/O	+3.3V
5	+3.3V	PWR	+3.3V
6	LFRAME#	IN	
7	LRESET#	OUT	+3.3V
8	GND	GND	
9	LCLK	OUT	
10	SMCLK	IN	
11	SMDAT	IN	
12	SERIRQ	I/O	+3.3V

### 2.4.14 SATA Connector (CN20, CN23, CN24, CN26)

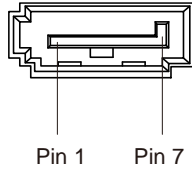

Pin	Pin name	Signal Type	Signal Level
1	GND	GND	
2	SATA_TX+	DIFF	
3	SATA_TX-	DIFF	
4	GND	GND	
5	SATA_RX-	DIFF	
6	SATA_RX+	DIFF	
7	GND	GND	

### 2.4.15 SATA Power Connector (CN21, CN22, CN25, CN27)

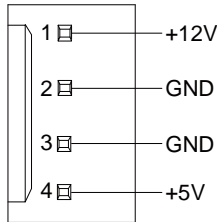

Pin	Pin name	Signal Type	Signal Level
1	+12V	PWR	+12V
2	GND	GND	
3	GND	GND	
4	+5V	PWR	+5V

## 2.4.16 Digital IO Port (CN28)

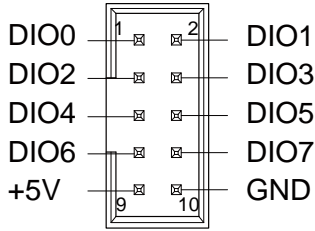

Pin	Pin name	Signal Type	Signal Level
1	DIO0	I/O	+5V
2	DIO1	I/O	+5V
3	DIO2	I/O	+5V
4	DIO3	I/O	+5V
5	DIO4	I/O	+5V
6	DIO5	I/O	+5V
7	DIO6	I/O	+5V
8	DIO7	I/O	+5V
9	+5V	PWR	+5V
10	GND	GND	

## 2.4.17 COM1, COM2 Connector (RS232/RS422/RS485) (CN29)

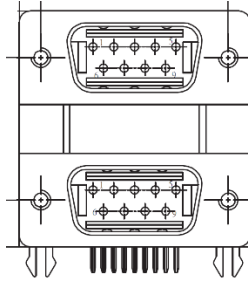

Pin	Pin name	Signal Type	Signal Level
1	DCD1	IN	
2	RX1	IN	
3	TX1	OUT	±9V
4	DTR1	OUT	±9V
5	GND	GND	
6	DSR1	IN	
7	RTS1	OUT	±9V
8	CTS1	IN	
9	RI1	IN	
10	DCD2	IN	
11	RX2	IN	
12	TX2	OUT	±9V
13	DTR2	OUT	±9V
14	GND	GND	
15	DSR2	IN	
16	RTS2	OUT	±9V
17	CTS2	IN	
18	RI2	IN	

## 2.4.18 COM Port 1 Wafer Box (Optional) (CN30)

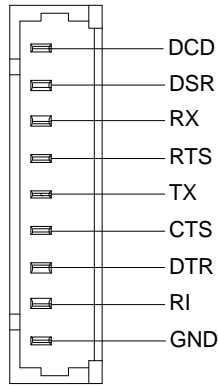

Pin	Pin Name	Signal Type	RS-422	RS-485
1	DCD1	IN	RS422_TX-	RS485_D-
2	DSR1	IN		
3	RX1	IN	RS422_TX+	RS485_D+
4	RTS1	OUT		
5	TX1	OUT	RS422_RX+	
6	CTS1	IN		
7	DTR1	OUT	RS422_RX+	
8	RI1	IN		
9	GND	GND		

## 2.4.19 COM Port 2 Wafer Box (Optional) (CN31)

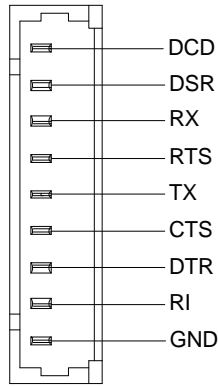

Pin	Pin Name	Signal Type	RS-422	RS-485
1	DCD2	IN	RS422_TX-	RS485_D-
2	DSR2	IN		
3	RX2	IN	RS422_TX+	RS485_D+
4	RTS2	OUT		
5	TX2	OUT	RS422_RX+	
6	CTS2	IN		
7	DTR2	OUT	RS422_RX+	
8	RI2	IN		
9	GND	GND		

## 2.4.20 COM3, COM4 Connector (RS232/RS422/RS485) (CN32)

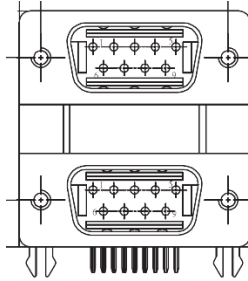

Pin	Pin name	Signal Type	Signal Level
1	DCD3	IN	
2	RX3	IN	
3	TX3	OUT	±9V
4	DTR3	OUT	±9V
5	GND	GND	
6	DSR3	IN	
7	RTS3	OUT	±9V
8	CTS3	IN	
9	RI3	IN	
10	DCD4	IN	
11	RX4	IN	
12	TX4	OUT	±9V
13	DTR4	OUT	±9V
14	GND	GND	
15	DSR4	IN	
16	RTS4	OUT	±9V
17	CTS4	IN	
18	RI4	IN	

## 2.4.21 COM Port 3 Wafer Box (Optional) (CN33)

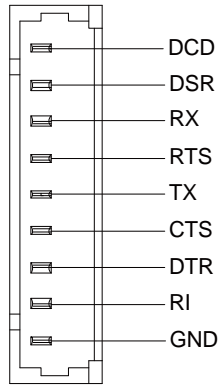

Pin	Pin Name	Signal Type	RS-422	RS-485
1	DCD3	IN	RS422_TX-	RS485_D-
2	DSR3	IN		
3	RX3	IN	RS422_TX+	RS485_D+
4	RTS3	OUT		
5	TX3	OUT	RS422_RX+	
6	CTS3	IN		
7	DTR3	OUT	RS422_RX+	
8	RI3	IN		
9	GND	GND		

## 2.4.22 COM Port 4 Wafer Box (Optional) (CN34)

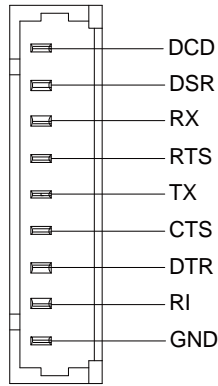

Pin	Pin Name	Signal Type	RS-422	RS-485
1	DCD4	IN	RS422_TX-	RS485_D-
2	DSR4	IN		
3	RX4	IN	RS422_TX+	RS485_D+
4	RTS4	OUT		
5	TX4	OUT	RS422_RX+	
6	CTS4	IN		
7	DTR4	OUT	RS422_RX+	
8	RI4	IN		
9	GND	GND		

## 2.4.23 COM Port 5 Wafer Box (Optional) (CN35)

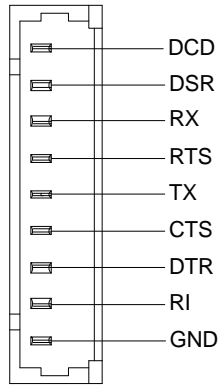

Pin	Pin Name	Signal Type	RS-422	RS-485
1	DCD5	IN	RS422_TX-	RS485_D-
2	DSR5	IN		
3	RX5	IN	RS422_TX+	RS485_D+
4	RTS5	OUT		
5	TX5	OUT	RS422_RX+	
6	CTS5	IN		
7	DTR5	OUT	RS422_RX+	
8	RI5	IN		
9	GND	GND		

## 2.4.24 COM Port 6 Wafer Box (Optional) (CN36)

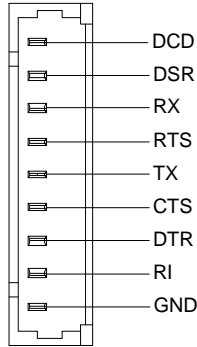

Pin	Pin Name	Signal Type	RS-422	RS-485
1	DCD6	IN	RS422_TX-	RS485_D-
2	DSR6	IN		
3	RX6	IN	RS422_TX+	RS485_D+
4	RTS16	OUT		
5	TX6	OUT	RS422_RX+	
6	CTS6	IN		
7	DTR6	OUT	RS422_RX+	
8	RI6	IN		
9	GND	GND		

## 2.4.25 Mini-Card Slot (Full-Sized) (CN37)

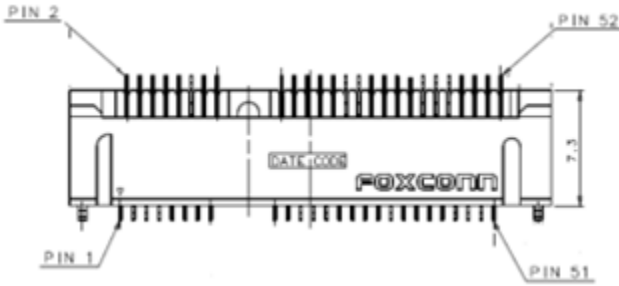

Pin	Pin name	Signal Type	Signal Level
1	PCIE_WAKE#	IN	
2	+3.3V	PWR	+3.3V
3	NC		
4	GND	GND	
5	NC		
6	+1.5V	PWR	+1.5V
7	PCIE_CLK_REQ#	IN	
8	UIM_PWR	PWR	
9	GND	GND	
10	UIM_DATA	I/O	
11	PCIE_REF_CLK-	DIFF	
12	UIM_CLK	IN	
13	PCIE_REF_CLK+	DIFF	
14	UIM_RESET	IN	
15	GND	GND	
16	UIM_VPP	PWR	
17	NC		
18	GND	GND	
19	NC		

Pin	Pin name	Signal Type	Signal Level
20	W_DISABLE#	OUT	+3.3V
21	GND	GND	
22	PCIE_RST#	OUT	+3.3V
23	PCIE_RX-	DIFF	
24	+3.3VSB	PWR	+3.3V
25	PCIE_RX+	DIFF	
26	GND	GND	
27	GND	GND	
28	+1.5V	PWR	+1.5V
29	GND	GND	
30	SMB_CLK	I/O	+3.3V
31	PCIE_TX-	DIFF	
32	SMB_DATA	I/O	+3.3V
33	PCIE_TX+	DIFF	
34	GND	GND	
35	GND	GND	
36	USB_D-	DIFF	
37	GND	GND	
38	USB_D+	DIFF	
39	+3.3VSB	PWR	+3.3V
40	GND	GND	
41	+3.3VSB	PWR	+3.3V
42	NC		
43	GND	GND	
44	NC		
45	NC		
46	NC		

Pin	Pin name	Signal Type	Signal Level
47	NC		
48	+1.5V	PWR	+1.5V
49	NC		
50	GND	GND	
51	NC		
52	+3.3VSB	PWR	+3.3V

#### 2.4.26 SIM Slot (CN38)

---

Pin	Pin name	Signal Type	Signal Level
1	UIM_PWR	PWR	
2	UIM_RST	IN	
3	UIM_CLK	IN	
4	GND	GND	
5	UIM_VPP	PWR	
6	UIM_DATA	I/O	

## 2.4.27 Mini-Card Slot (Half-Sized) (CN39)

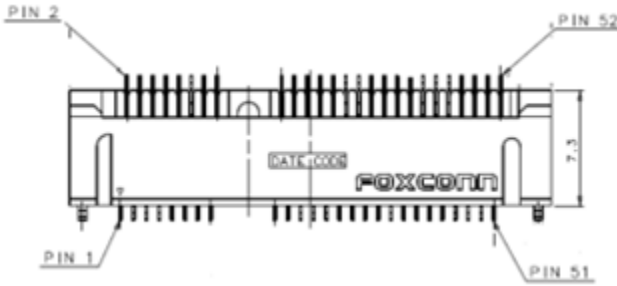

Pin	Pin name	Signal Type	Signal Level
1	PCIE_WAKE#	IN	
2	+3.3V	PWR	+3.3V
3	NC		
4	GND	GND	
5	NC		
6	+1.5V	PWR	+1.5V
7	PCIE_CLK_REQ#	IN	
8	NC	PWR	
9	GND	GND	
10	NC	I/O	
11	PCIE_REF_CLK-	DIFF	
12	NC	IN	
13	PCIE_REF_CLK+	DIFF	
14	NC	IN	
15	GND	GND	
16	NC	PWR	
17	NC		
18	GND	GND	
19	NC		

Pin	Pin name	Signal Type	Signal Level
20	W_DISABLE#	OUT	+3.3V
21	GND	GND	
22	PCIE_RST#	OUT	+3.3V
23	PCIE_RX-/SATA_RX+	DIFF	
24	+3.3VSB	PWR	+3.3V
25	PCIE_RX+/SATA_RX-	DIFF	
26	GND	GND	
27	GND	GND	
28	+1.5V	PWR	+1.5V
29	GND	GND	
30	SMB_CLK	I/O	+3.3V
31	PCIE_TX-/SATA_TX-	DIFF	
32	SMB_DATA	I/O	+3.3V
33	PCIE_TX+/SATA_TX+	DIFF	
34	GND	GND	
35	GND	GND	
36	USB_D-	DIFF	
37	GND	GND	
38	USB_D+	DIFF	
39	+3.3VSB	PWR	+3.3V
40	GND	GND	
41	+3.3VSB	PWR	+3.3V
42	NC		
43	GND	GND	
44	NC		
45	MINICARD_SATA_PCIE_DET	IN	
46	NC		

Pin	Pin name	Signal Type	Signal Level
47	NC		
48	+1.5V	PWR	+1.5V
49	NC		
50	GND	GND	
51	NC		
52	+3.3VSB	PWR	+3.3V

### 2.4.28 USB 2.0 Wafer Box (CN40, CN41, CN42, CN43)

**Note:** USB2.0 Wafer Box (5P Pitch: 1.25mm)

Pin	Pin name	Signal Type	Signal Level
1	+5V	GND	+5V
2	USBD-	DIFF	
3	USBD+	DIFF	
4	GND	GND	
5	GND	GND	

## 2.4.29 Audio Jack Connector (CN44)

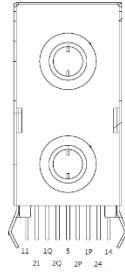

Pin	Pin Name	Signal Type	Signal Level
11	MIC_R		
21	LOUT_R		
1Q	HP_DET2		
5	GND	GND	
2P	HP_DET3		
1P	HP_DET1		
24	LOUT_L		
14	MIC_L		

### 2.4.30 Audio Connector Wafer Box (CN45)

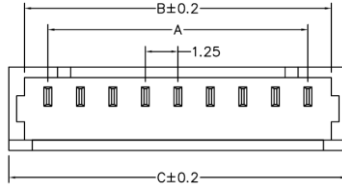

Pin	Pin Name	Signal Type	Signal Level
1	MIC_L		
2	MIC_R		
3	GND	GND	
4	LIN_L		
5	LIN_R		
6	GND	GND	
7	LOUT_L		
8	LOUT_R		
9	GND	GND	
10	VDD_AUD	PWR	5V

### 2.4.31 DC-IN Connector (CN48)

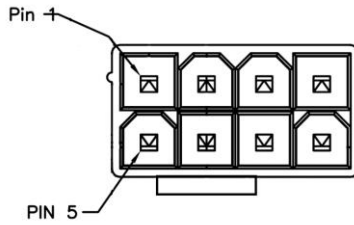

Pin	Pin Name	Signal Type	Signal Level
1	GND	GND	
2	GND	GND	
3	GND	GND	
4	GND	GND	
5	VIN	PWR	+10V~+35V
6	VIN	PWR	+10V~+35V
7	VIN	PWR	+10V~+35V
8	VIN	PWR	+10V~+35V

### 2.4.32 GPU DC-IN Connector (CN50, CN51)

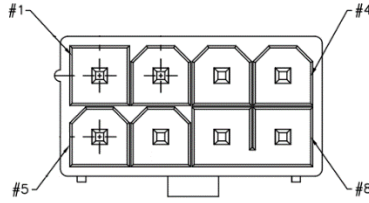

Pin	Pin Name	Signal Type	Signal Level
1	+12V	PWR	+12V
2	+12V	PWR	+12V
3	+12V	PWR	+12V
4	+12V	PWR	+12V
5	GND	GND	
6	GND	GND	
7	GND	GND	
8	GND	GND	

### 2.4.33 RTC Battery Connector (BAT1)

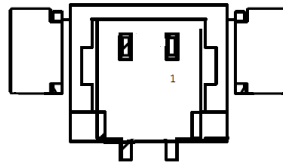

Pin	Pin Name	Signal Type	Signal Level
1	+3.3VA_RTC	PWR	3.3v
2	GND	GND	

## 2.5 CPU Installation

Step 1: Power down the system, unplug the power cord and ensure the system is off.

Step 2: Have 8<sup>th</sup> Generation Intel Core, Xeon, Celeron or Pentium CPU ready. See Chapter 1 for processor compatibility.

Step 3: Remove the six (6) screws from the side of the BOXER-6842M case as shown, then remove side cover.

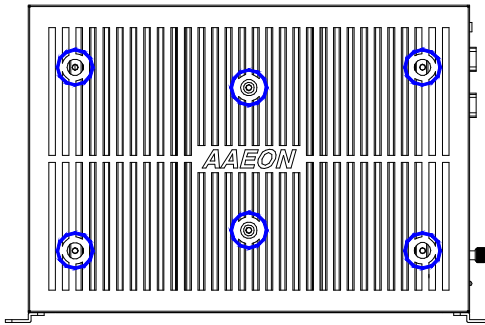

Step 4: Insert CPU into CPU slot. Place thermal pad on top of CPU.

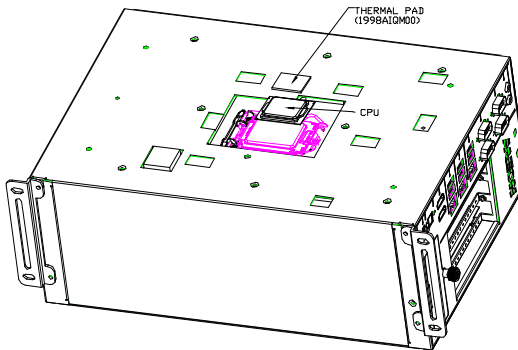

Step 5: Reattach side cover and secure with screws from Step 3.

## 2.6 DDR4 Memory Module Installation

Step 1: Power down the system, unplug the power cord and ensure the system is off.

Step 2: Have RAM modules ready. See Chapter 1 for RAM compatibility and support.

Step 3: Remove four (4) screws from top of system as shown.

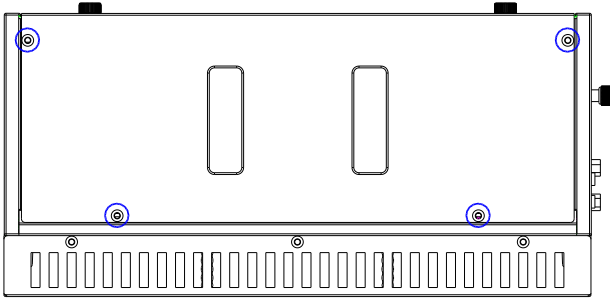

Step 4: Remove the two screws from side cover (Note: opposite side from CPU cover).  
Remove side cover from system.

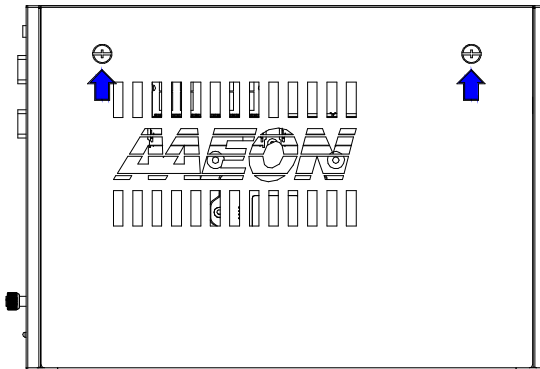

Step 5: Note there are two sets of RAM slots, with an inner (against the board; CN1, CN3) and outer (away from board; CN2, CN4) slot.

Step 6: Insert RAM modules into inner slot for each set, with thermal pad placed **under** the modules, between the board and module.

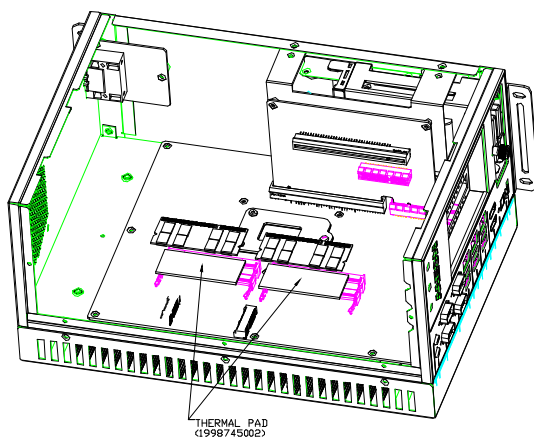

Step 7: Insert RAM modules into outer slot for each set.

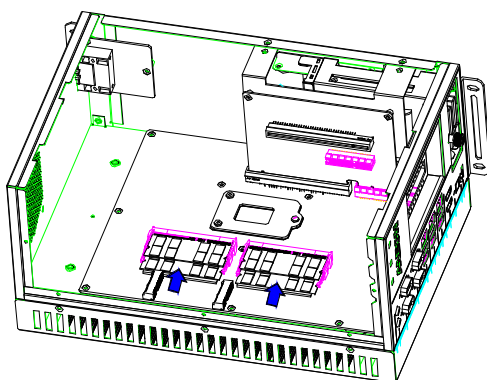

Step 8: Reattach outer cover, securing with screws from Steps 3 and 4.

## 2.7 2.5" SATA Drive Installation

Step 1: Power down the system, unplug the power cord and ensure the system is off.

Step 2: Have 2.5" SATA drive ready.

Step 3: Remove the screw securing the 2.5" SATA drive bay cover as shown. Remove the SATA drive carrier.

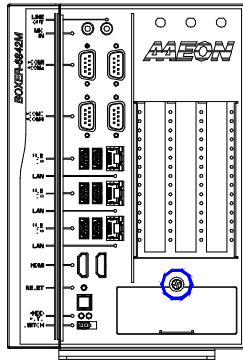

Step 4: Place 2.5" SATA drive into drive carrier and secure with four (4) screws as shown.

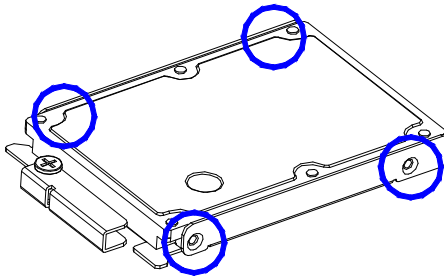

Step 5: Slide 2.5" SATA drive assembly into SATA drive bay as shown.

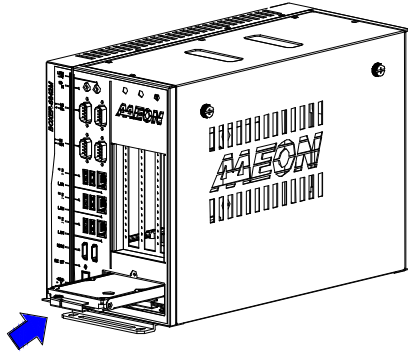

Step 6: Replace SATA drive bay cover and attach with screw removed in Step 3.

## 2.8 Graphics Card Installation

BOXER-6842M supports PCIe[x16] graphics card with standard height of 114.55mm or shorter. Length should be under 280mm.

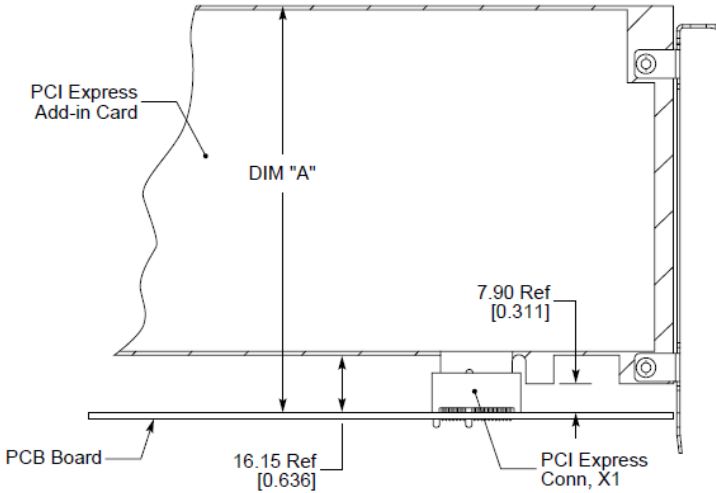

DIM "A"	
STANDARD HEIGHT	114.55 [4.510] MAX.
LOW PROFILE	72.30 [2.846] MAX.

**Note:** If the power connector is on the side of graphics card instead of on the top (as in the picture below), card length should be under 260mm.



The BOXER-6842M supports graphics cards with power requirement up to 300W. This requires connecting a graphics card power cable from the motherboard to the graphics card. Follow the steps below to install the graphics card.

**Note:** The BOXER-6842M does not require a separate power adapter for the graphics card.

Step 1: Locate the PCIe power connector on the motherboard.

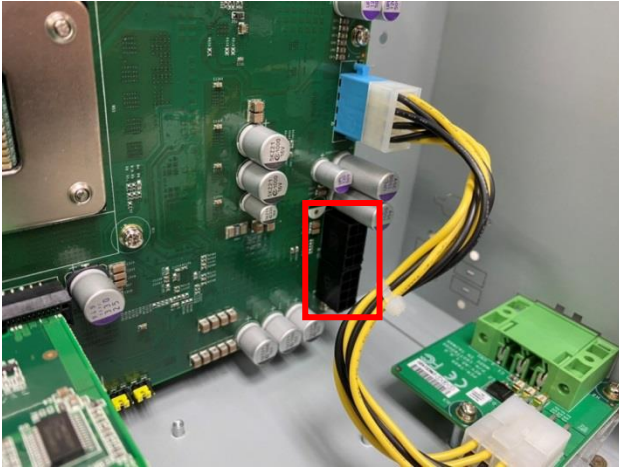

Step 2: Connect the graphics card power cable.

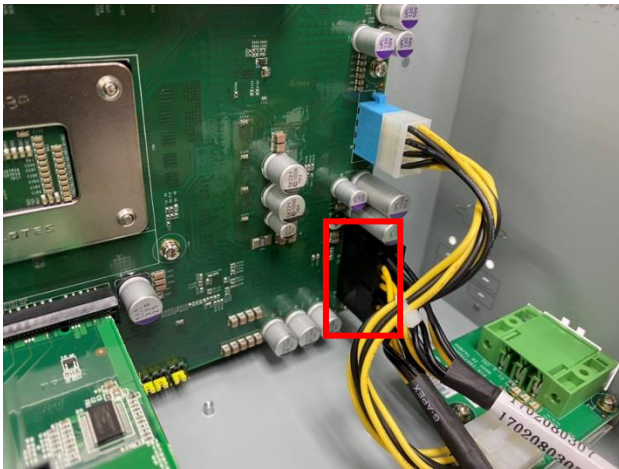

Step 3: Install the graphics card and secure with two screws as shown.

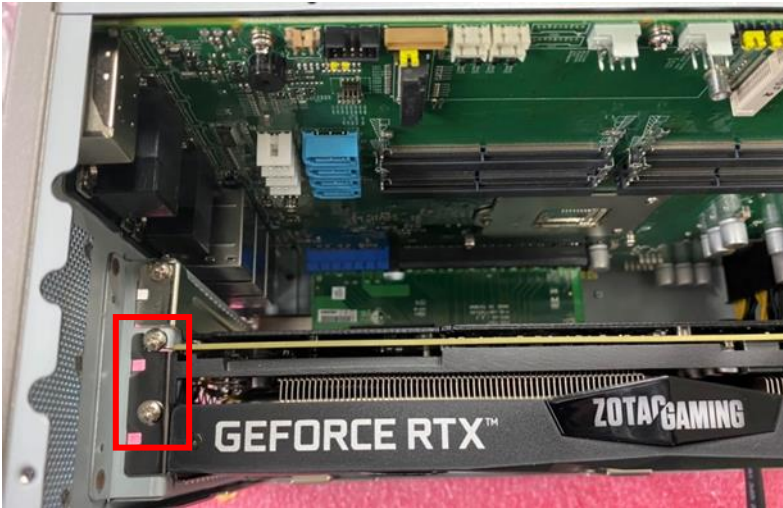
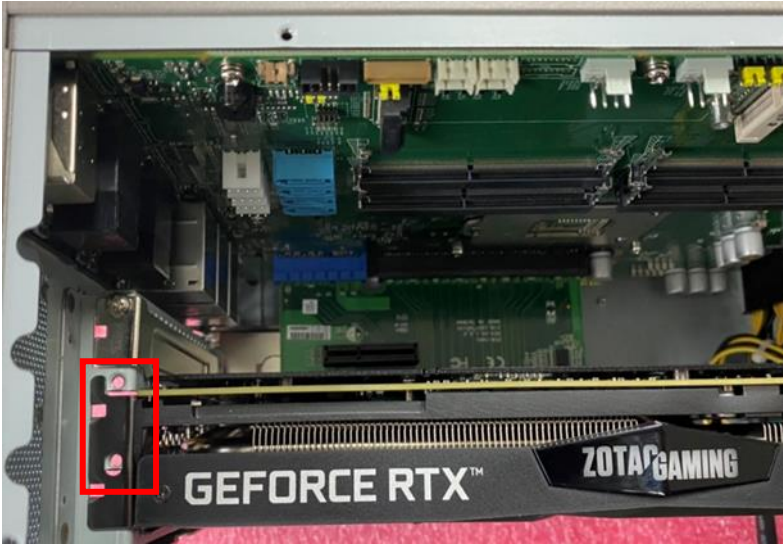

Step 4: Connect the graphics power cable to the graphics card.

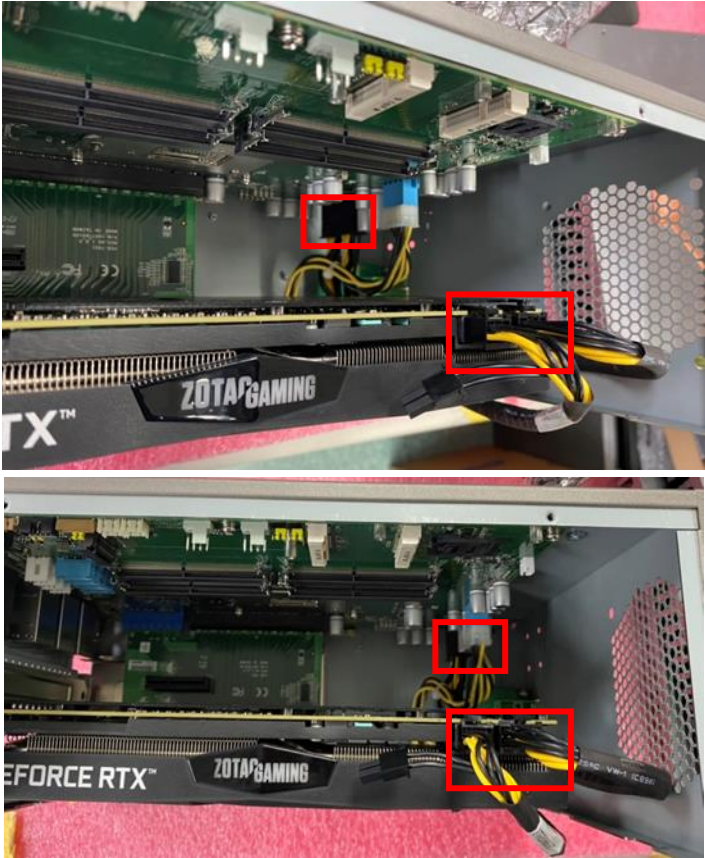

## 2.9 Connecting System Power

This section details the steps to connecting the BOXER-6842M to power and powering up the system.

Step 1: Insert the 12V-24V system power input.



Step 2: Ensure the system is connected to a monitor. Press the power button to power on the system. The system should output a display to the monitor.



# Chapter 3

---

AMI BIOS Setup

## 3.1 System Test and Initialization

---

The system uses certain routines to perform testing and initialization during the boot up sequence. If an error, fatal or non-fatal, is encountered, the system will output a few short beeps or an error message. The board can usually continue the boot up sequence with non-fatal errors.

The system configuration verification routines check the current system configuration against the values stored in the CMOS memory. If they do not match, the system will output an error message, and the BIOS setup program will need to be run to set the configuration information in memory.

There are three situations in which the CMOS settings will need to be set or changed:

- Starting the system for the first time
- The system hardware has been changed
- The CMOS memory has lost power and the configuration information is erased

The system's CMOS memory uses a backup battery for data retention. The battery must be replaced when it runs down.

## 3.2 AMI BIOS Setup

---

The AMI BIOS ROM has a pre-installed Setup program that allows users to modify basic system configurations. Configuration information is stored in the battery-backed CMOS RAM and BIOS NVRAM so that the information is retained when system power is turned off.

To enter BIOS Setup, press <Del> immediately while your computer is powering up.

The function for each interface can be found below.

**Main** – Date and time can be set here. Press <Tab> to switch between date elements

**Advanced** – Enable/ Disable boot option for legacy network devices

**Chipset** – Host bridge parameters

**Security** – The setup administrator password can be set here

**Boot** – Enable/ Disable Quiet Boot option

**Save & Exit** – Save your changes and exit the program

### 3.3 Main – Setup Submenu

Aptio Setup Utility - Copyright (C) 2020 American Megatrends, Inc.

Main Advanced Chipset Security Boot Save & Exit

BIOS Information BOXER-6842M R1.0 (B842AM10) (02/24/2020)	Set the Date. Use Tab to switch between Date elements. Default Ranges: Year: 2005-2099 Months: 1-12 Days: dependent on month
BIOS Vendor Compliance	American Megatrends UEFI 2.7; PI 1.6
System Date System Time	[Tue 02/25/2020] [07:24:32]
Access Level	Administrator

++: Select Screen  
↑↓: Select Item  
Enter: Select  
+/-: Change Opt.  
F1: General Help  
F2: Previous Values  
F3: Optimized Defaults  
F4: Save & Exit  
ESC: Exit

Version 2.20.1275. Copyright (C) 2020 American Megatrends, Inc.

### 3.4 Advanced – Setup Submenu

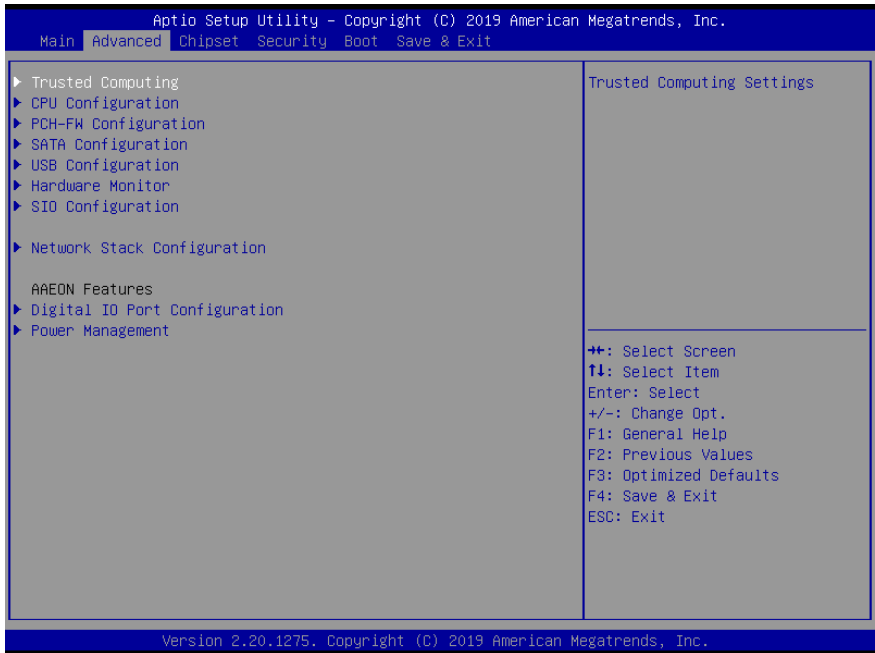

### 3.4.1 Advanced: Trusted Computing



Options Summary		
<b>Security Device Support</b>	Enable	Optimal Default, Failsafe Default
	Disable	
Enable or Disable BIOS support for security device. TCG EFI protocol and INT1A interface will not be available.		
<b>SHA-1 PCR Bank</b>	Enabled	Optimal Default, Failsafe Default
	Disabled	
Enable or Disable SHA-1 PCR Bank		
<b>SHA256 PCR Bank</b>	Enabled	Optimal Default, Failsafe Default
	Disabled	
Enable or Disable SHA256 PCR Bank		
<b>Pending operation</b>	None	Optimal Default, Failsafe Default
	TPM Clear	
Schedule an Operation for the Security Device. NOTE: Your Computer will reboot during restart in order to change State of Security Device.		

Table Continues on Next Page...

Options Summary		
Platform Hierarchy	Enabled	Optimal Default, Failsafe Default
	Disabled	
Enable or Disable Platform Hierarchy		
Storage Hierarchy	Enabled	Optimal Default, Failsafe Default
	Disabled	
Enable or Disable Storage Hierarchy		
Endorsement Hierarchy	Enabled	Optimal Default, Failsafe Default
	Disabled	
Enable or Disable Endorsement Hierarchy		
TPM2.0 UEFI Spec Version	TCG_2	Optimal Default, Failsafe Default
	TCG_1_2	
Select the TCG2 Spec Version Support TCG_1_2: Compatible mode for Win8/Win10 TCG_2: Support new TCG2 protocol and event format for Win10 or later		
Physical Presence Spec Version	1.3	Optimal Default, Failsafe Default
	1.2	
Select to Tell O.S. to support PPI Spec Version 1.2 or 1.3. Note some HCK tests might not support 1.3.		
Device Select	Auto	Optimal Default, Failsafe Default
	TPM 1.2	
	TPM 2.0	
TPM 1.2 will restrict support to TPM 1.2 devices, TPM 2.0 will restrict support to TPM 2.0 devices, Auto will support both with the default set to TPM 2.0 devices if not found, TPM 1.2 devices will be enumerated		

### 3.4.2 Advanced: CPU Configuration

Fanless Embedded Box PC  
BOXER-6842M

Aptio Setup Utility - Copyright (C) 2019 American Megatrends, Inc.

Advanced

CPU Configuration		When enabled, a VMM can utilize the additional hardware capabilities provided by Vanderpool Technology.  ++: Select Screen T1: Select Item Enter: Select +/-: Change Opt. F1: General Help F2: Previous Values F3: Optimized Defaults F4: Save & Exit ESC: Exit
Name	CoffeeLake DT	
Type	Intel(R) Core(TM) i7-9700TE CPU @ 1.80GHz	
Speed	1800 MHz	
ID	0x906ED	
Stepping	R0	
Package	LGA1151	
Number of Processors	8Core(s) / 8Thread(s)	
Microcode Revision	C6	
GT Info	GT2 (0x3E98)	
eDRAM Size	N/A	
VMX	Supported	
SMX/TXT	Supported	
Intel (VMX) Virtualization Technology	[Enabled]	
Active Processor Cores	[All]	
Intel(R) SpeedStep(tm)	[Enabled]	
Intel(R) Speed Shift Technology	[Disabled]	
Turbo Mode	[Enabled]	
C states	[Disabled]	

Version 2.20.1275. Copyright (C) 2019 American Megatrends, Inc.

Options Summary		
<b>Intel (VMX) Virtualization Technology</b>	Disabled	Optimal Default, Failsafe Default
	Enabled	
When enabled, a VMM can utilize the additional hardware capabilities provided by Vanderpool Technology.		
<b>Active Processor Cores</b>	1	Optimal Default, Failsafe Default
	2	
	3	
	All	
Number of cores to enable in each processor package.		
<b>Intel(R) SpeedStep(tm)</b>	Disabled	Optimal Default, Failsafe Default
	Enabled	
Allows more than two frequency ranges to be supported.		
<b>Intel(R) Speed Shift Technology</b>	Disabled	Optimal Default, Failsafe Default
	Enabled	
Enable/Disable Intel(R) Speed Shift Technology support. Enabling will expose the CPPC v2 interface to allow for hardware controlled P-states.		

Options Summary		
Turbo Mode	Disabled	Optimal Default, Failsafe Default
	Enabled	
Enable/Disable Processor Turbo Mode (requires Intel Speed Step or Intel Speed Shift to be available or enabled).		
C states	Disabled	Optimal Default, Failsafe Default
	Enabled	
Enable/Disable CPU Power Management. Allows CPU to go C states when it's not 100% utilized		

### 3.4.3 Advanced: PCH-FW Configuration

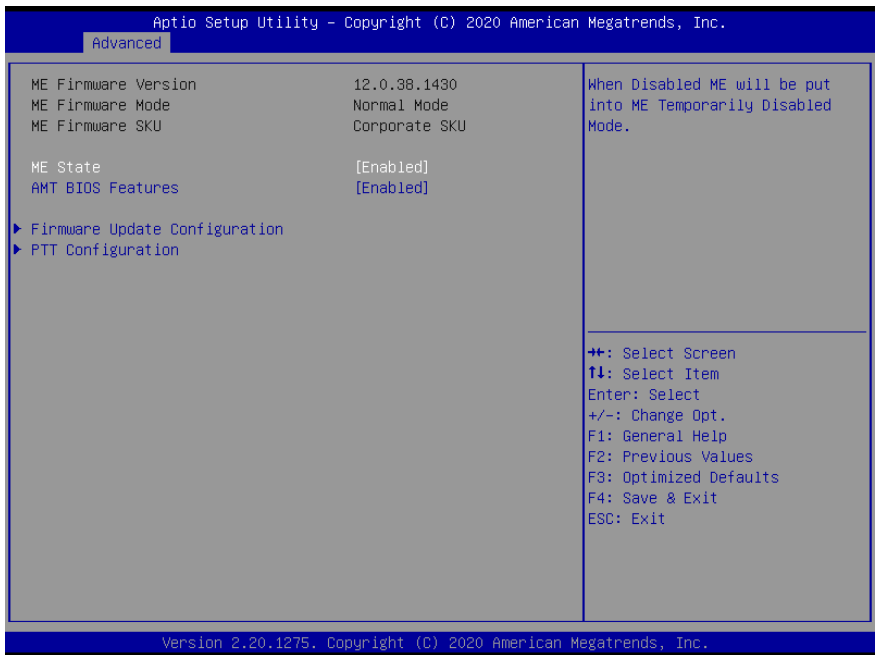

Options Summary		
ME State	Enabled	Optimal Default, Failsafe Default
	Disabled	
When Disabled ME will be put into ME Temporarily Disabled Mode.		
AMT BIOS Features	Enabled	Optimal Default, Failsafe Default
	Disabled	
When disabled AMT BIOS Features are no longer supported and user is no longer able to access MEBx Setup.		
Note:		
This option does not disable Manageability Features in FW.		

### 3.4.3.1 Firmware Update Configuration

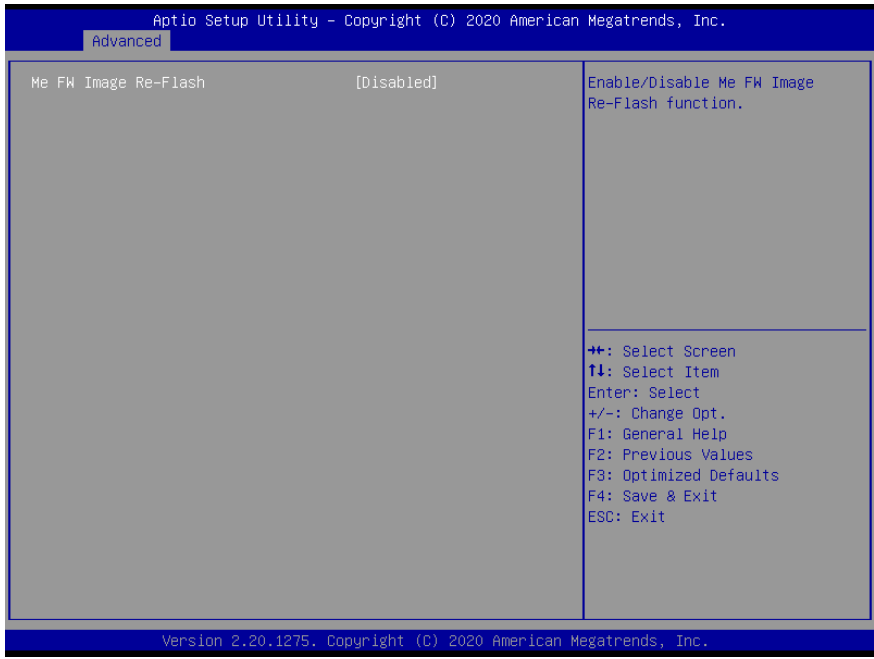

Options Summary		
ME FW Image Re-Flash	Enabled	Optimal Default, Failsafe Default
	Disabled	
Enable/Disable ME FW Image Re-Flash function.		

### 3.4.3.2 PTT Configuration

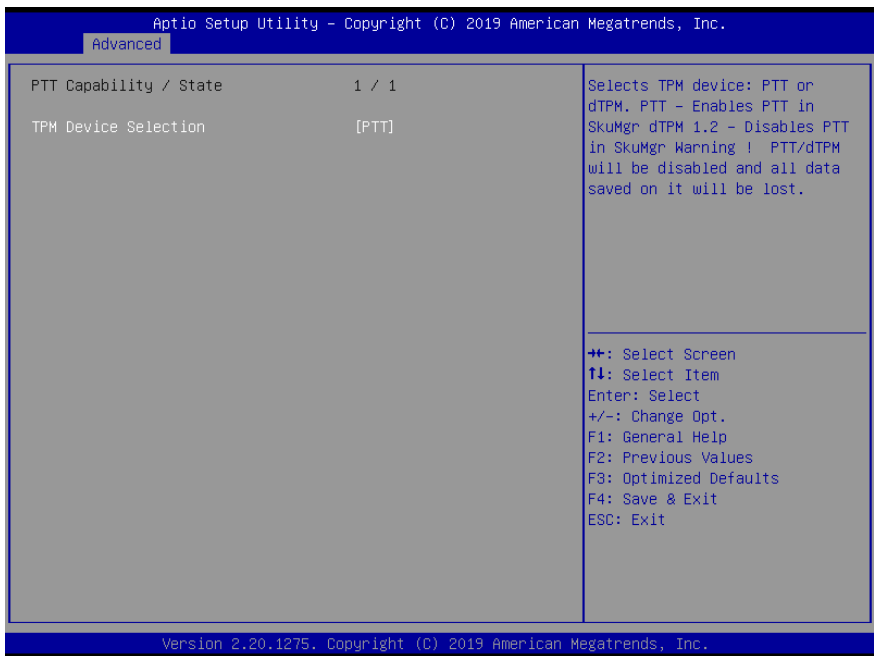

Options Summary		
<b>ME FW Image Re-Flash</b>	dTPM	Optimal Default, Failsafe Default
	PTT	
Selects TPM device: PTT or dTPM. PTT – Enables PTT in SkuMgr dTPM 1.2 – Disables PTT in SkuMgr Warning! PTT/dTPM will be disabled and all saved data on it will be lost.		

### 3.4.4 Advanced: SATA Configuration

Fanless Embedded Box PC  
BOXER-6842M

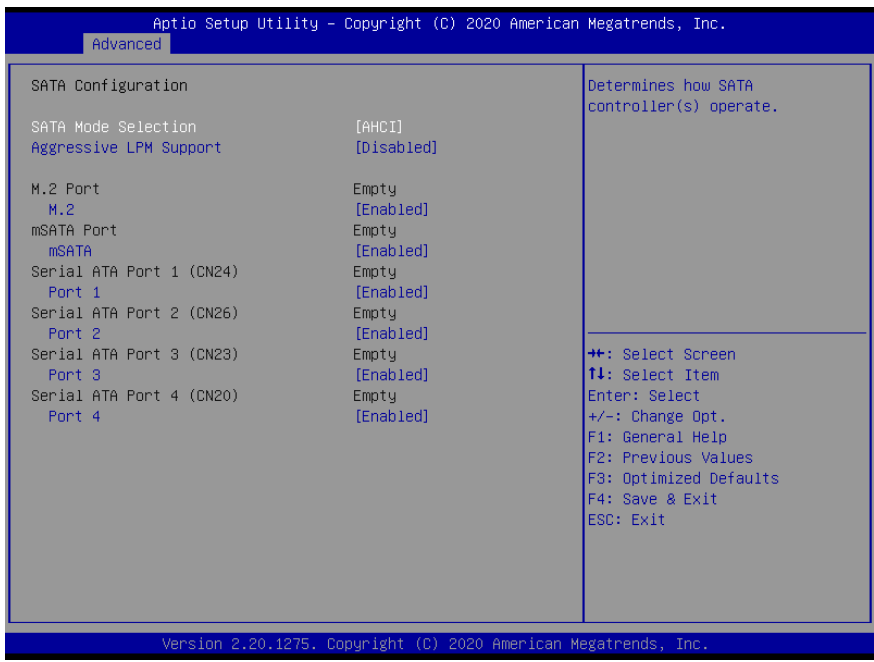

Options Summary		
SATA Mode Selection	AHCI Mode	Optimal Default, Failsafe Default
	Intel RST Premium with Intel Optane System Acceleration	
Determines how SATA controller(s) operate.		
Aggressive LPM Support	Enabled	Optimal Default, Failsafe Default
	Disabled	
Enable PCH to aggressively enter link power state.		
M.2/mSATA Port	Enabled	Optimal Default, Failsafe Default
	Disabled	
Enable or Disable SATA Port.		
Serial ATA Port 1/2/3/4	Enabled	Optimal Default, Failsafe Default
	Disabled	
Enable or Disable SATA Port.		

### 3.4.5 Advanced: USB Configuration

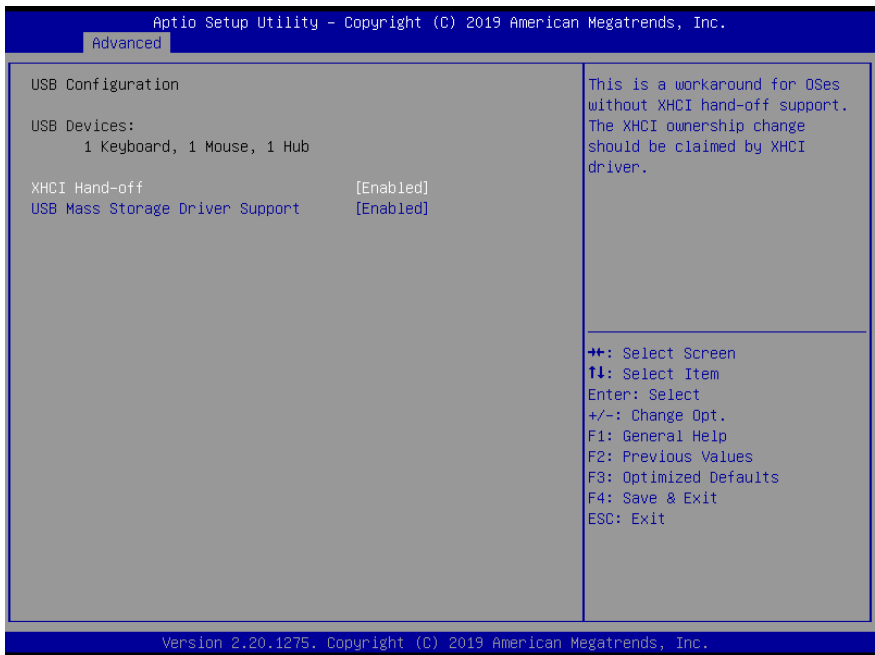

Options Summary		
XHCI Hand-off	Enabled	Optimal Default, Failsafe Default
	Disabled	
This is a workaround for OSes without XHCI Hand-off support. The XHCI ownership change should be claimed by XHCI driver.		
USB Mass Storage Driver Support	Enabled	Optimal Default, Failsafe Default
	Disabled	
Enable/Disable USB Mass Storage Driver Support.		

### 3.4.6 Advanced: Hardware Monitor

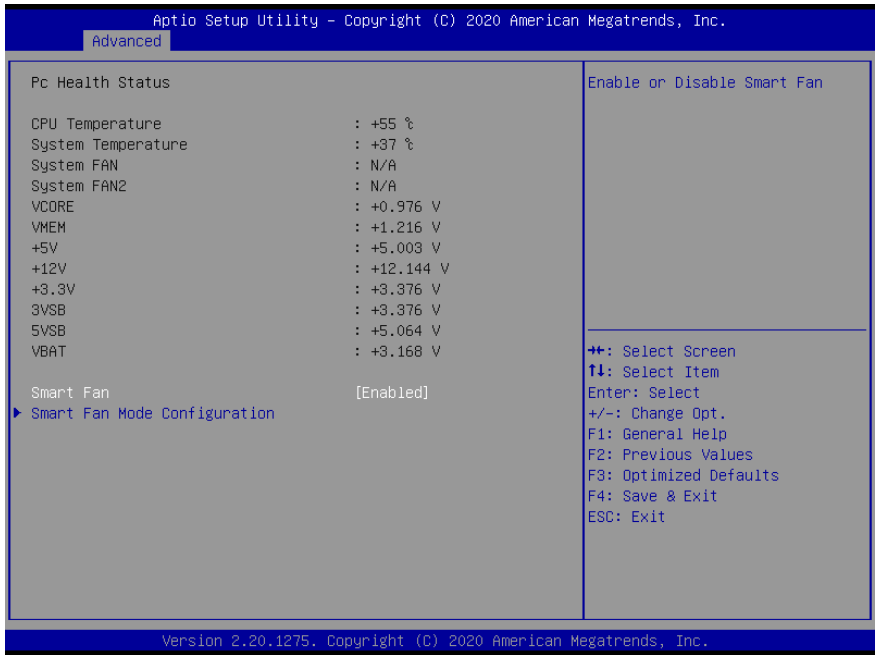

Options Summary		
Smart Fan	Enabled	Optimal Default, Failsafe Default
	Disabled	
Enable or Disable Smart Fan		

### 3.4.6.1 Smart Fan Mode Configuration

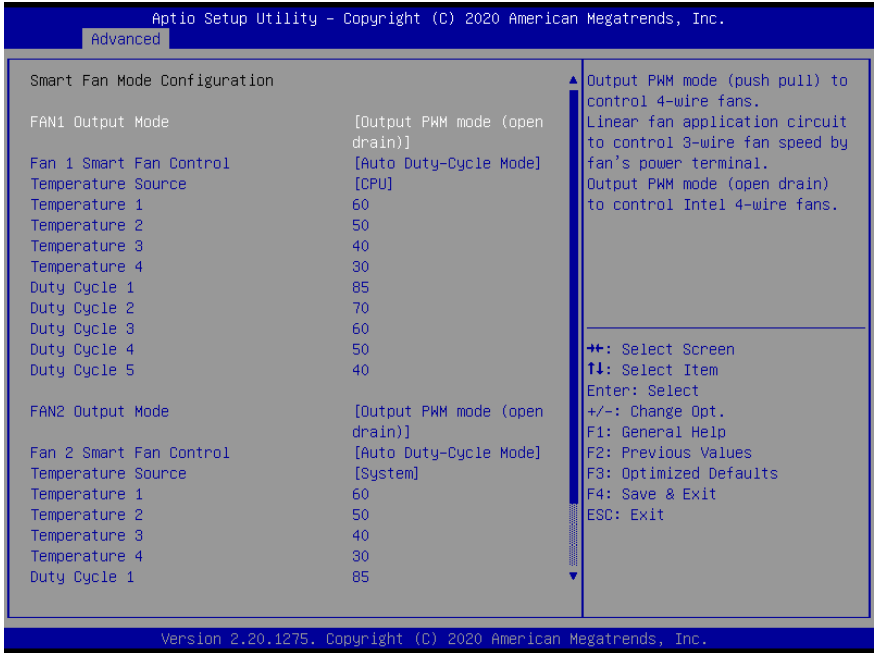

Options Summary		
Fan 1/2 Output Mode	Output PWM mode (push pull)	Optimal Default, Failsafe Default
	Linear Fan Application	
	Output PWM mode (open drain)	
Output PWM mode (push pull) to control 4-wire fans. Linear fan application circuit to control 3-wire fan speed by fan's power terminal. Output PWM mode (open drain) to control Intel 4-wire fans.		
Fan 1/2 Smart Fan Control	Manual RPM Mode	Optimal Default, Failsafe Default
	Manual Duty Mode	
	Auto RPM Mode	
	Auto Duty-Cycle Mode	
Smart Fan Mode Select		
Temperature Source	CPU	Optimal Default, Failsafe Default
	System	
Select the monitored temperature source for this fan		

Options Summary		
Temperature 1/2/3/4	1-100	Range
	60/50/40/30	Optimal Default, Failsafe Default
Auto fan speed control. Fan speed will follow different temperature by different duty cycle 1-100		
Duty Cycle 1/2/3/4/5	1-100	Range
	85/70/60/50/40	Optimal Default, Failsafe Default
Auto fan speed control. Fan speed will follow different temperature by different duty cycle 1-100		

### 3.4.7 Advanced: SIO Configuration

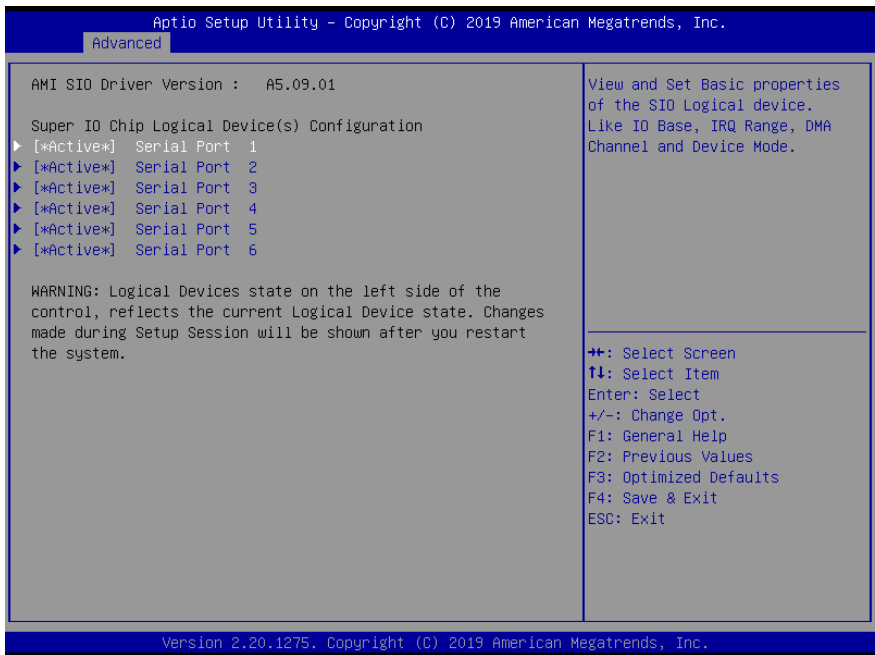

### 3.4.7.1 Serial Port1

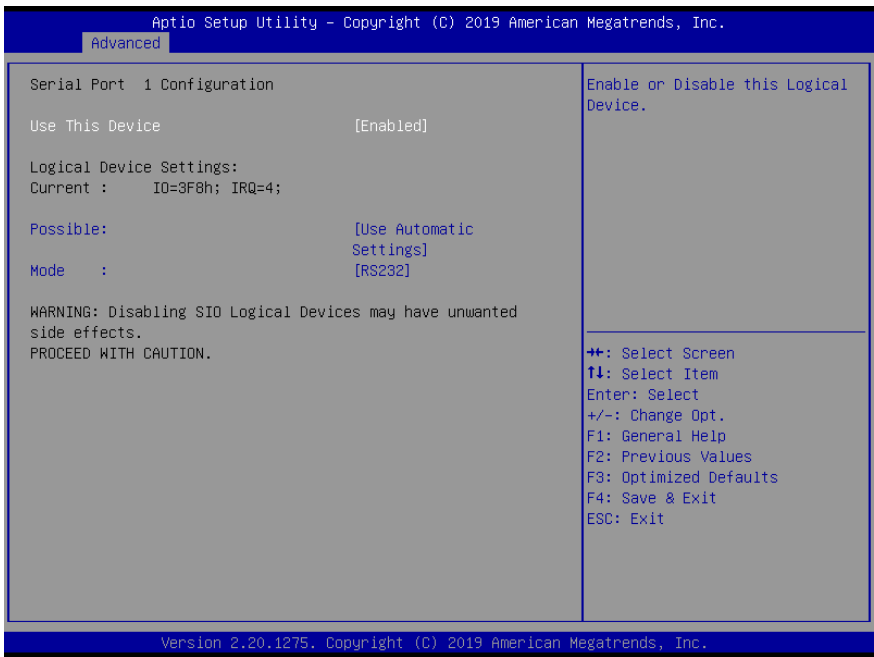

Options Summary		
Use This Device	Enabled	Optimal Default, Failsafe Default
	Disabled	
Enable or Disable this Logical Device.		
Device resource settings	USB Automatic Setting	Optimal Default, Failsafe Default
	IO=3F8h; IRQ = 4;	
	IO=2F8h; IRQ = 3;	
Allows the user to change the device resource settings. New settings will be reflected on this setup page after system restarts.		
UART selection	RS232	Optimal Default, Failsafe Default
	RS422	
	RS485	
UART RS232, 422, 485 selection.		

### 3.4.7.2 Serial Port2

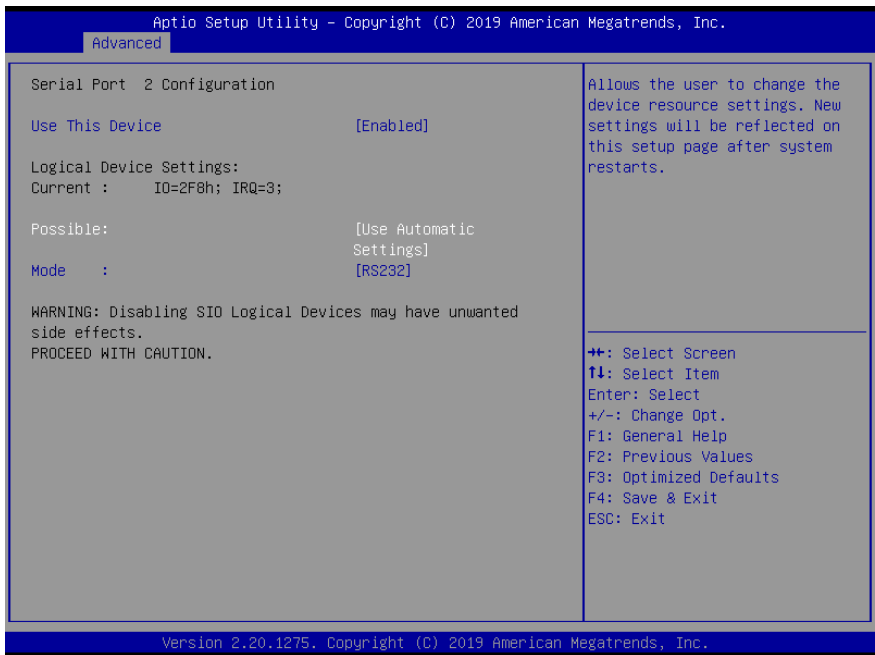

Options Summary		
Use This Device	Enabled	Optimal Default, Failsafe Default
	Disabled	
Enable or Disable this Logical Device.		
Device resource settings	USB Automatic Setting	Optimal Default, Failsafe Default
	IO=2F8h; IRQ = 3;	
	IO=3F8h; IRQ = 4;	
Allows the user to change the device resource settings. New settings will be reflected on this setup page after system restarts.		
UART selection	RS232	Optimal Default, Failsafe Default
	RS422	
	RS485	
UART RS232, 422, 485 selection.		

### 3.4.7.3 Serial Port3

Aptio Setup Utility - Copyright (C) 2019 American Megatrends, Inc.

Advanced

<p>Serial Port 3 Configuration</p> <p>Use This Device <span style="float: right;">[Enabled]</span></p> <p>Logical Device Settings: Current : IO=3E8h; IRQ=11;</p> <p>Possible: <span style="float: right;">[Use Automatic Settings]</span></p> <p>Mode : <span style="float: right;">[RS232]</span></p> <p>WARNING: Disabling SIO Logical Devices may have unwanted side effects. PROCEED WITH CAUTION.</p>	<p>Allows the user to change the device resource settings. New settings will be reflected on this setup page after system restarts.</p> <hr/> <p>           ++: Select Screen            T1: Select Item            Enter: Select            +/-: Change Opt.            F1: General Help            F2: Previous Values            F3: Optimized Defaults            F4: Save &amp; Exit            ESC: Exit         </p>
---	---

Version 2.20.1275. Copyright (C) 2019 American Megatrends, Inc.

Options Summary		
<b>Use This Device</b>	Enabled	Optimal Default, Failsafe Default
	Disabled	
Enable or Disable this Logical Device.		
<b>Device resource settings</b>	USB Automatic Setting	Optimal Default, Failsafe Default
	IO=3E8h; IRQ = 11;	
	IO=2E8h; IRQ = 11;	
Allows the user to change the device resource settings. New settings will be reflected on this setup page after system restarts.		
<b>UART selection</b>	RS232	Optimal Default, Failsafe Default
	RS422	
	RS485	
UART RS232, 422, 485 selection.		

### 3.4.7.4 Serial Port4

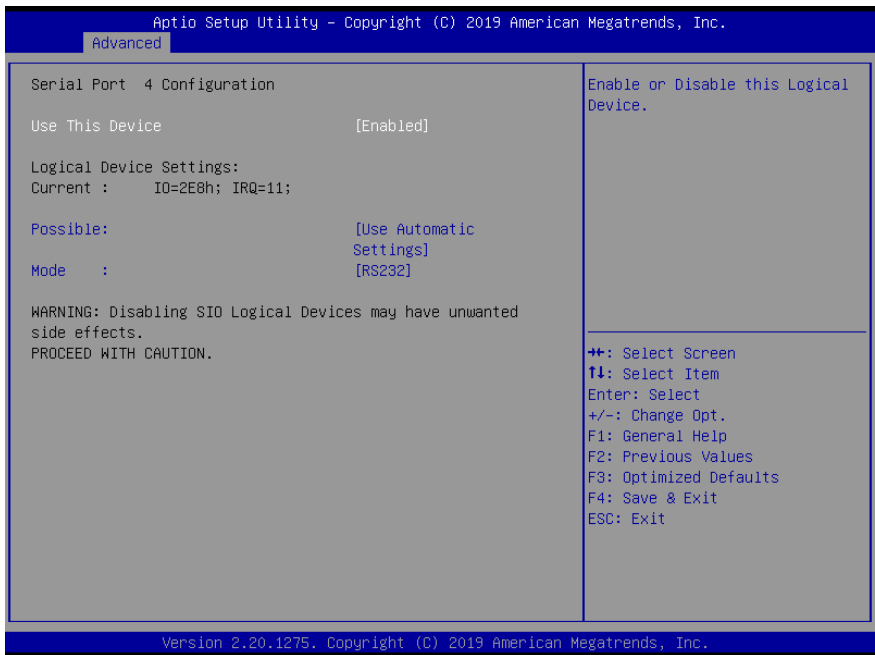

Options Summary		
Use This Device	Enabled	Optimal Default, Failsafe Default
	Disabled	
Enable or Disable this Logical Device.		
Device resource settings	USB Automatic Setting	Optimal Default, Failsafe Default
	IO=2E8h; IRQ = 11;	
	IO=3E8h; IRQ = 11;	
Allows the user to change the device resource settings. New settings will be reflected on this setup page after system restarts.		
UART selection	RS232	Optimal Default, Failsafe Default
	RS422	
	RS485	
UART RS232, 422, 485 selection.		

### 3.4.7.5 Serial Port5

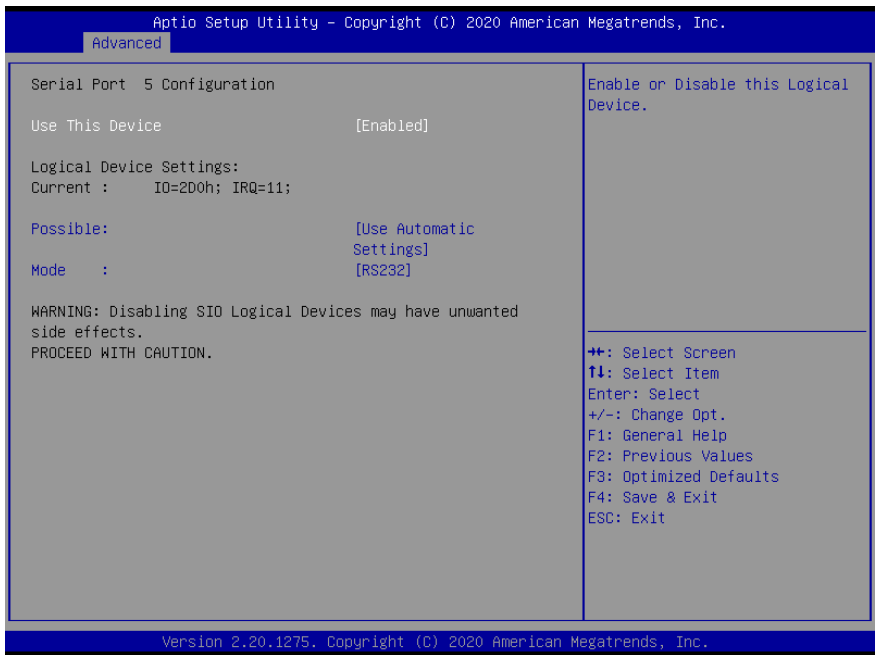

Options Summary		
Use This Device	Enabled	Optimal Default, Failsafe Default
	Disabled	
Enable or Disable this Logical Device.		
Device resource settings	USB Automatic Setting	Optimal Default, Failsafe Default
	IO=2D0h; IRQ = 11;	
	IO=2C0h; IRQ = 11;	
Allows the user to change the device resource settings. New settings will be reflected on this setup page after system restarts.		
UART selection	RS232	Optimal Default, Failsafe Default
	RS422	
	RS485	
UART RS232, 422, 485 selection.		

### 3.4.7.6 Serial Port6

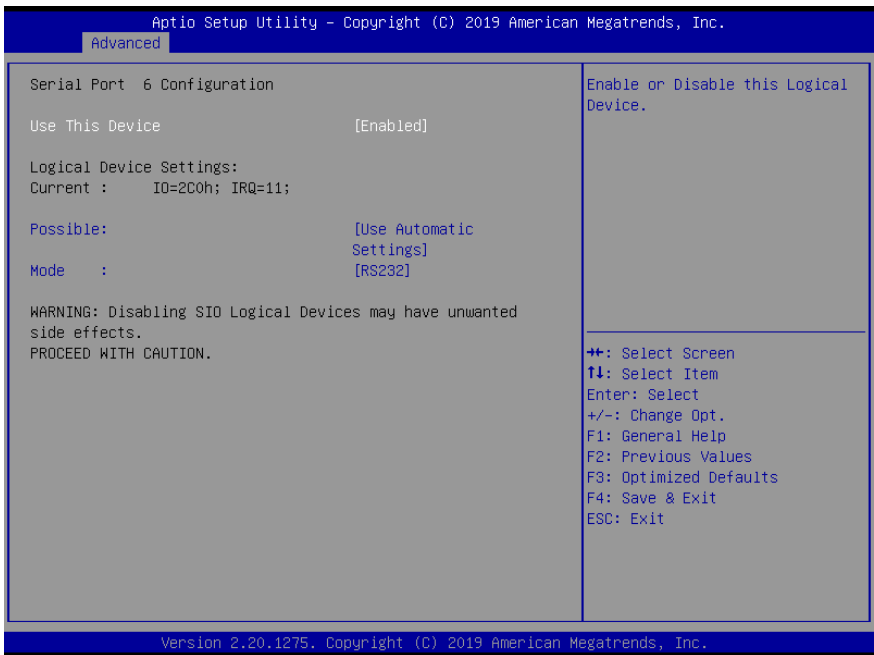

Options Summary		
Use This Device	Enabled	Optimal Default, Failsafe Default
	Disabled	
Enable or Disable this Logical Device.		
Device resource settings	USB Automatic Setting	Optimal Default, Failsafe Default
	IO=2C0h; IRQ = 11;	
	IO=2D0h; IRQ = 11;	
Allows the user to change the device resource settings. New settings will be reflected on this setup page after system restarts.		
UART selection	RS232	Optimal Default, Failsafe Default
	RS422	
	RS485	
UART RS232, 422, 485 selection.		

### 3.4.8 Advanced: Network Stack Configuration



Network Stack Disabled View

Options Summary		
Network Stack	Disabled	Optimal Default, Failsafe Default
	Enabled	
Enable/Disable UEFI Network Stack		

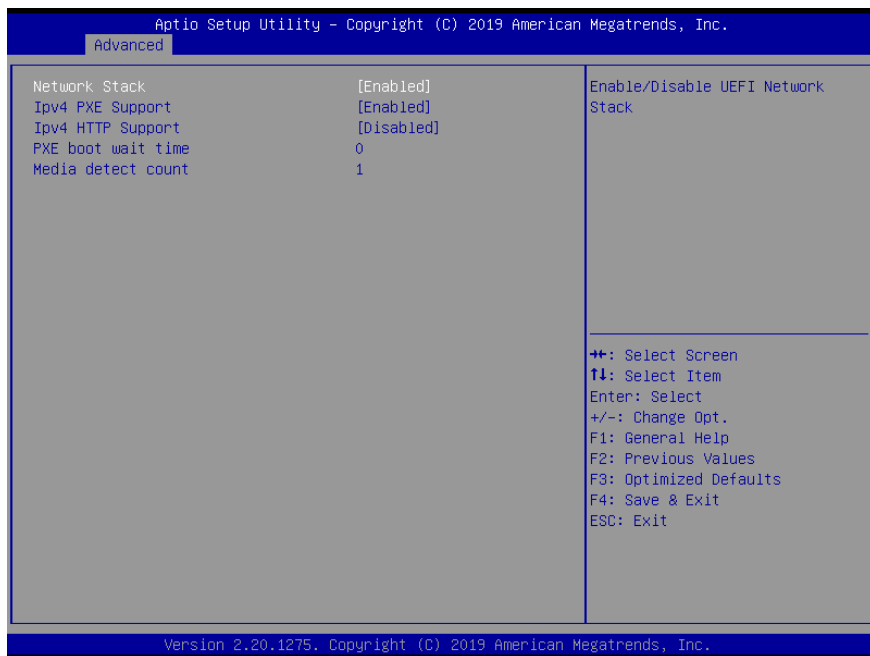

## Network Stack Enabled View

Options Summary		
Network Stack	Disabled	Optimal Default, Failsafe Default
	Enabled	
Enable/Disable UEFI Network Stack		
Ipv4 PXE Support	Disabled	Optimal Default, Failsafe Default
	Enabled	
Enable/Disable IPv4 PXE boot support. If disabled, IPv4 PXE boot support will not be available.		
Ipv4 HTTP Support	Disabled	Optimal Default, Failsafe Default
	Enabled	
Enable/Disable IPv4 HTTP boot support. If disabled, IPv4 HTTP boot support will not be available.		
PXE boot wait time	0	Optimal Default, Failsafe Default
Wait time in seconds to press ESC key to abort the PXE boot. Use either +/- or numeric keys to set the value.		
Media detect count	1	Optimal Default, Failsafe Default
Number of times the presence of media will be checked. Use either +/- or numeric keys to set the value.		

### 3.4.9 Advanced: Digital IO Port Configuration

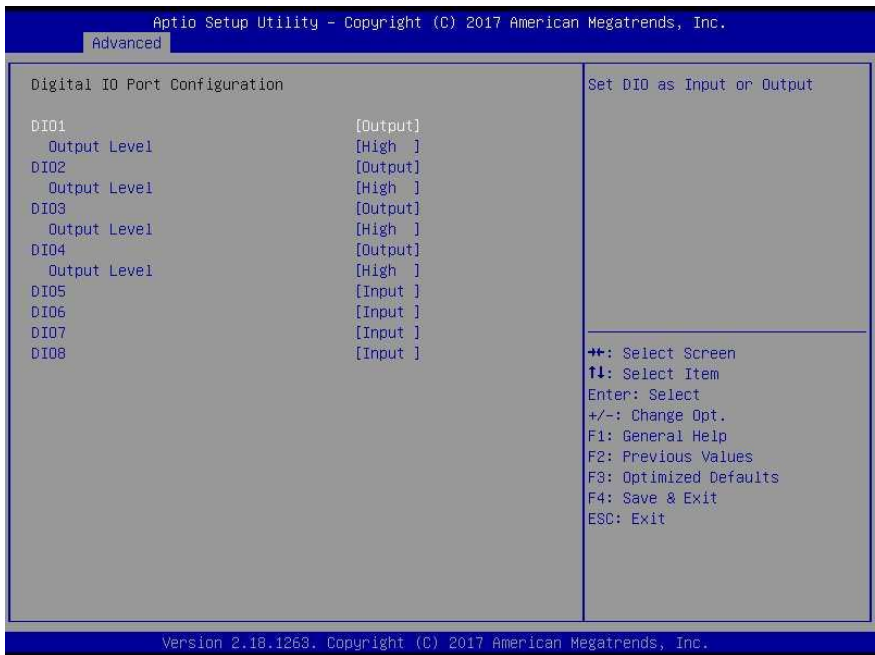

Options Summary		
DIO Type	Output	Optimal Default, Failsafe Default
	Input	
Set DIO as Input or Output		
DIO Data	Low	Optimal Default, Failsafe Default
	High	
Set is output level when DIO pin is output		

### 3.4.10 Advanced: Power Management

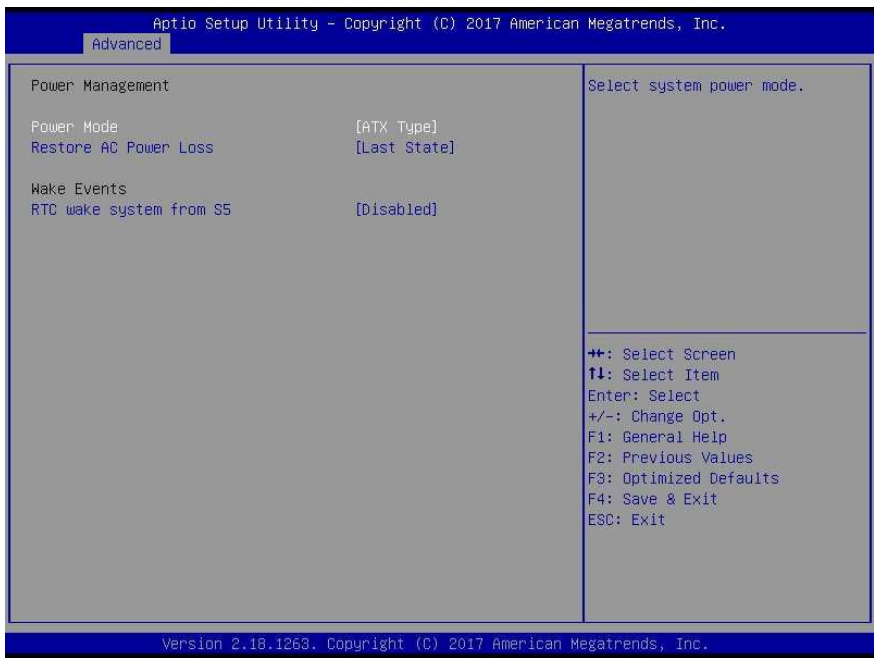

Options Summary		
Power Mode	ATX Type AT Type	Optimal Default, Failsafe Default
Select power supply mode.		
AC Power Loss	Last State Power On Power Off	Optimal Default, Failsafe Default
Select power state when power is re-applied after a power failure.		
RTC wake system from S5	Disabled Enabled	Optimal Default, Failsafe Default
Fixed Time: System will make on the hr::min::sec specified./n Dynamic Time: System will wake on the current time + Increase minute(S)		
RTC wake system from S5	Enabled	
Wake up day	0	
Select 0 for daily system wake up, 1-31 for which day of the month that you would like system to wake up		

Options Summary	
Wake up hour	0
Select 0-23 For example enter 3 for 3am and 15 for 3pm	
Wake up minute	0
0 - 59	
Wake up second	0
0 - 59	

### 3.5 Chipset – Setup Submenu

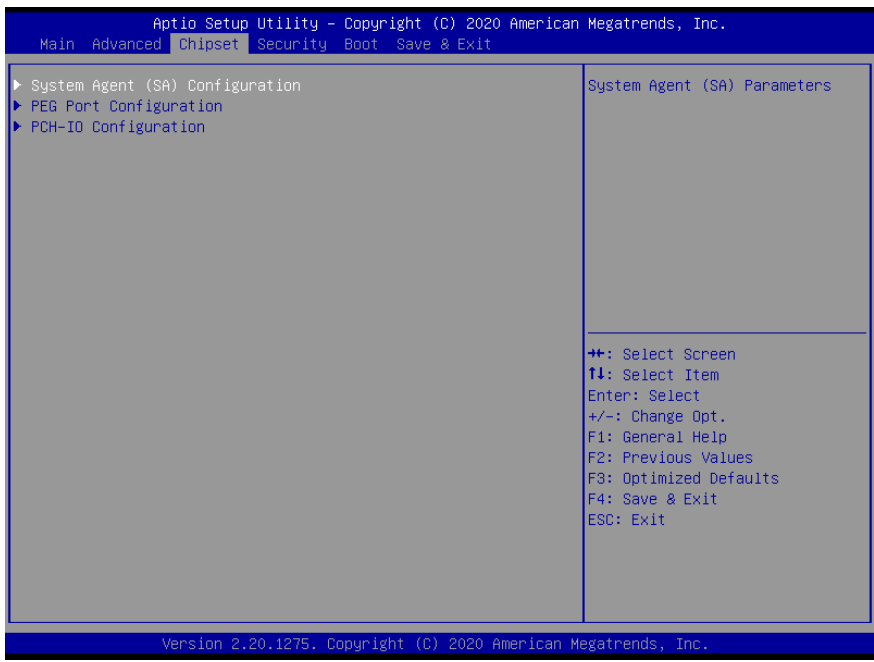

### 3.5.1 Chipset: System Agent (SA) Configuration

Fanless Embedded Box PC  
BOXER-6842M

Aptio Setup Utility - Copyright (C) 2020 American Megatrends, Inc.  
Chipset

System Agent (SA) Configuration		Select which of IGFX/PEG/PCI Graphics device should be Primary Display Or select SG for Switchable Gfx.
Total Memory	4096 MB	
Memory Frequency	2133 MHz	
Memory Timings (tCL-tRCD-tRP-tRAS)	15-15-15-36	
Channel 0 Slot 0	Not Populated / Disabled	
Channel 0 Slot 1	Not Populated / Disabled	
Channel 1 Slot 0	Populated & Enabled	
Size	4096 MB (DDR4)	
Channel 1 Slot 1	Not Populated / Disabled	
VT-d	Supported	
Primary Display	[Auto]	++: Select Screen T1: Select Item Enter: Select +/-: Change Opt. F1: General Help F2: Previous Values F3: Optimized Defaults F4: Save & Exit ESC: Exit
SA GV	[Enabled]	
PM Support	[Enabled]	
RC6(Render Standby)	[Enabled]	
DVMT Total Gfx Mem	[MAX]	
VT-d	[Disabled]	
Skip Scanning of External Gfx Card	[Disabled]	

Version 2.20.1275. Copyright (C) 2020 American Megatrends, Inc.

Options Summary						
Primary Display	<table border="1" style="width: 100%; border-collapse: collapse;"> <tr><td style="padding: 2px;">Auto</td></tr> <tr><td style="padding: 2px;">IGFX</td></tr> <tr><td style="padding: 2px;">PEG</td></tr> </table>	Auto	IGFX	PEG	Optimal Default, Failsafe Default	
Auto						
IGFX						
PEG						
Select which of IGFX/PEG/PCI Graphics device should be Primary Display Or select SG for Switchable Gfx.						
SA GV	<table border="1" style="width: 100%; border-collapse: collapse;"> <tr><td style="padding: 2px;">Enabled</td></tr> <tr><td style="padding: 2px;">Disabled</td></tr> <tr><td style="padding: 2px;">Fixed Low</td></tr> <tr><td style="padding: 2px;">Fixed High</td></tr> </table>	Enabled	Disabled	Fixed Low	Fixed High	Optimal Default, Failsafe Default
Enabled						
Disabled						
Fixed Low						
Fixed High						
System Agent Gyserville. Fixed Low/Mid/High: SA GV disabled, MRC only runs tasks From Low, Mid, or High point. SA GV will be disabled on DT/Halo CPUs, regardless of this setting.						
PM Support	<table border="1" style="width: 100%; border-collapse: collapse;"> <tr><td style="padding: 2px;">Enabled</td></tr> <tr><td style="padding: 2px;">Disabled</td></tr> </table>	Enabled	Disabled	Optimal Default, Failsafe Default		
Enabled						
Disabled						
Enable/Disable PM Support.						

Options Summary		
RC6(Render Standby)	Enabled	Optimal Default, Failsafe Default
	Disabled	
Check to enable render standby support.		
DVMT Total Gfx Mem	128M	Optimal Default, Failsafe Default
	256M	
	MAX	
Select DVMT5.0 Total Graphic Memory sized used by the Internal Graphics Device.		
VT-d	Enabled	Optimal Default, Failsafe Default
	Disabled	
VT-d capability.		
Skip Scanning of External Gfx Card	Enabled	Optimal Default, Failsafe Default
	Disabled	
If Enabled, it will not scan for External Gfx Card on PEG and PCH PCIE Ports		

### 3.5.2 Chipset: PEG Port Configuration

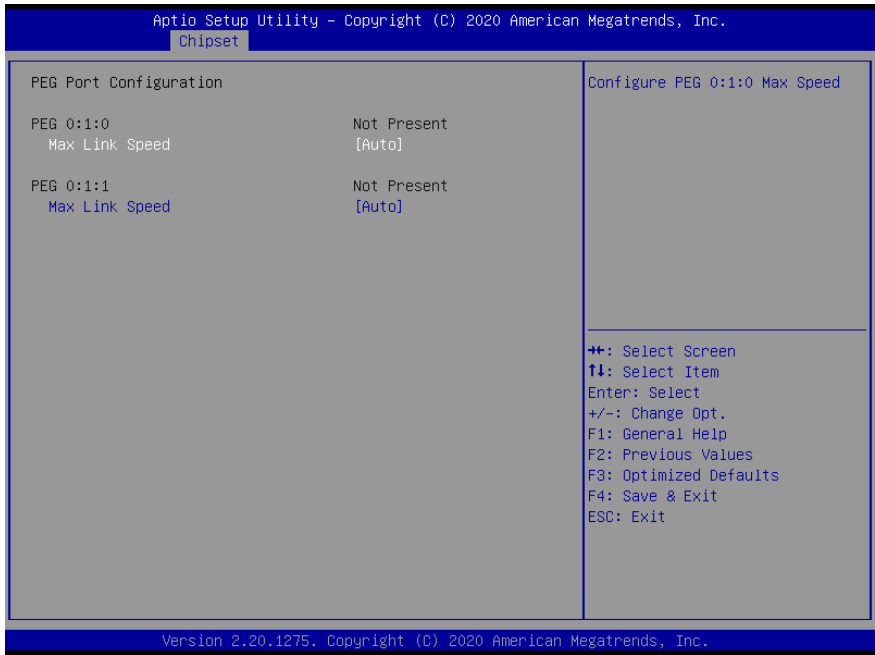

Options Summary		
Max Link Speed	Auto	Optimal Default, Failsafe Default
	Gen 1	
	Gen 2	
	Gen 3	
Configure PEG 0:1:0/0:1:1 Max Speed		

### 3.5.3 Chipset: PCH-IO Configuration

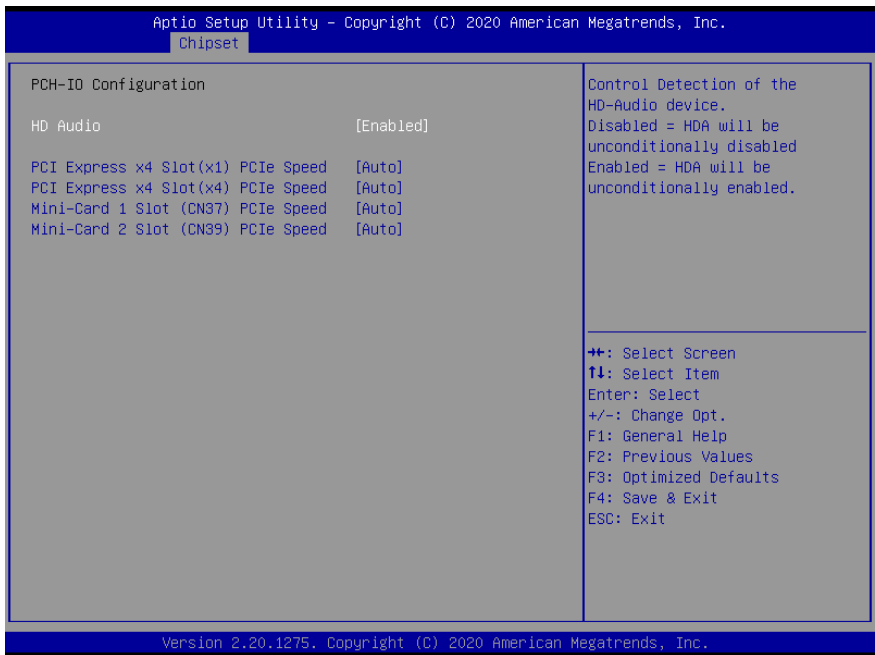

Options Summary		
HD Audio	Disabled	Optimal Default, Failsafe Default
	Enabled	
Control Detection of the HD-Audio device. Disabled = HDA will be unconditionally disabled Enabled = HDA will be unconditionally enabled.		
PCI Express x4 Slot (x1/x4) PCIe Speed	Auto	Optimal Default, Failsafe Default
	Gen1	
	Gen2	
Configure PCIe Speed		
Mini-Card 1/2 Slot PCIe Speed	Auto	Optimal Default, Failsafe Default
	Gen1	
	Gen2	
Configure PCIe Speed		

### 3.6 Security – Setup Submenu

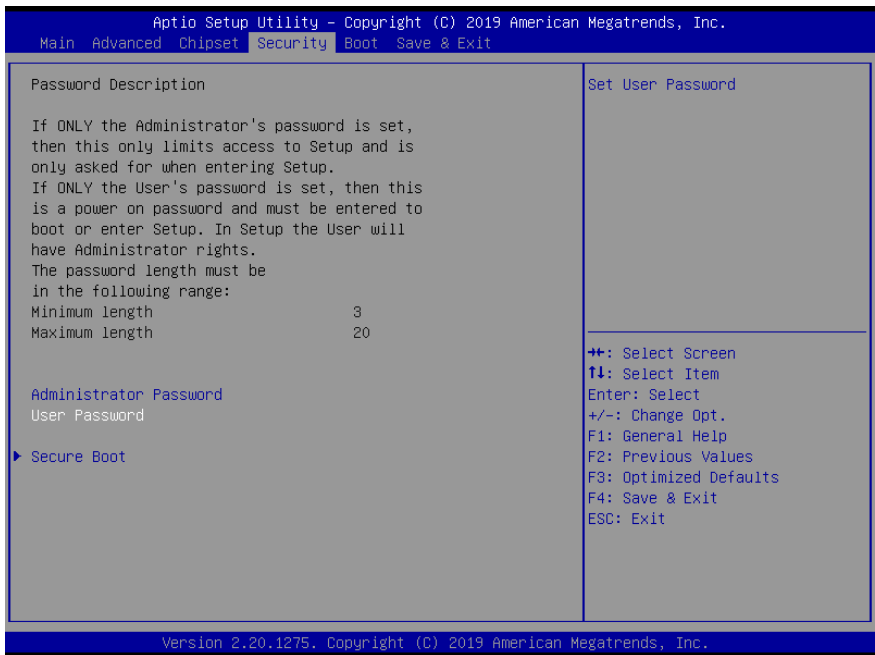

#### Change User/Administrator Password

You can set an Administrator Password or User Password. An Administrator Password must be set before you can set a User Password. The password will be required during boot up, or when the user enters the Setup utility. A User Password does not provide access to many of the features in the Setup utility.

Select the password you wish to set, and press Enter. In the dialog box, enter your password (must be between 3 and 20 letters or numbers). Press Enter and retype your password to confirm. Press Enter again to set the password.

#### Removing the Password

Select the password you want to remove and enter the current password. At the next dialog box press Enter to disable password protection.

### 3.6.1 Security: Secure Boot

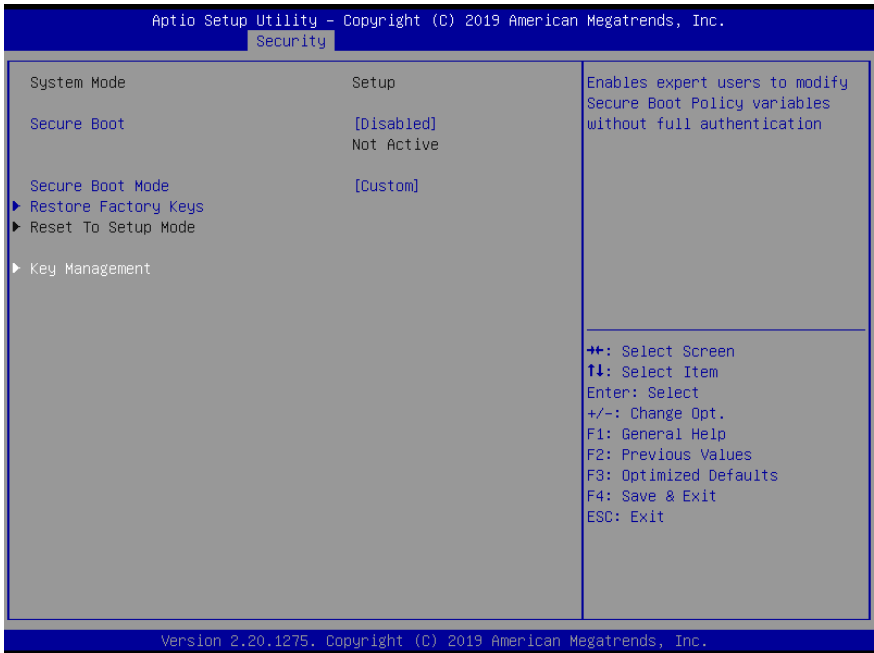

Options Summary		
<b>Secure Boot</b>	Disable	Optimal Default, Failsafe Default
	Enable	
Secure Boot feature is Active if Secure Boot is Enabled, Platform Key (PK) is enrolled and the System mode is in User mode. The mode change requires platform reset.		
<b>Secure Boot Mode</b>	Standard	Optimal Default, Failsafe Default
	Custom	
Secure Boot Mode options: Standard or Custom. In Custom mode, Secure Boot Policy variables can be configured by a physically present user without full authentication.		
<b>Restore Factory Keys</b>	Yes	
	No	
Force System to User Mode. Install factory default Secure Boot key databases		
<b>Key Management</b>		
Enables expert users to modify Secure Boot Policy variables without full authentication		

### 3.6.11 Key Management

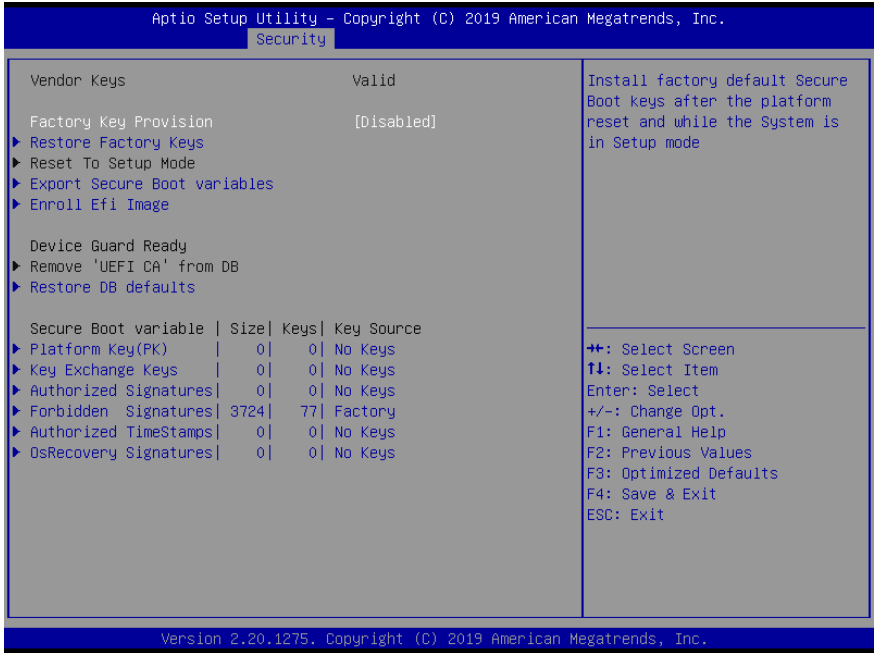

Options Summary		
Factory Key Provision	Disabled	Optimal Default, Failsafe Default
	Enabled	
Install factory default Secure Boot keys after the platform reset and while the System is in Setup mode.		
Restore Factory Keys	No	Press 'Yes' to install factory default keys
	Yes	
Force System to User Mode. Install Factory default Secure Boot key databases.		
Exported	Acpi(a0341d0, 0)\PCI(12 0)\DevicePath(Type 3, SubType 18)HD(Part2, Sig ?)\	
Copy NVRAM content of Secure Boot variables to files in a root folder on a file system device.		
Enroll Efi Image	Acpi(a0341d0, 0)\PCI(12 0)\DevicePath(Type 3, SubType 18)HD(Part2, Sig ?)\	
Allow the image to run in Secure Boot mode.		
Enroll SHA256 Hash Certificate of a PE Image into Authorized Signature Database (db).		

Options Summary		
Secure Boot variable	Size	Keys#   key Source
Platform Key(PK)   0   0   No Key		Update Enroll Factory Defaults or load certificates from a file: 1.Public key Certificate: a)EFI_SIGNATURE_LIST b)EFI_CERT_X509 (DER) c)EFI_CERT_RSA2048 (bin) d)EFI_CERT_SHAXXX 2.Authenticated UEFI Variable 3.EFI PE/COFF Image(SHA256) Key Source: Factory, External, Mixed
Key Exchange keys   0   0   No Key		Update Append Enroll Factory Defaults or load certificates from a file: 1.Public key Certificate: a)EFI_SIGNATURE_LIST b)EFI_CERT_X509 (DER) c)EFI_CERT_RSA2048 (bin) d)EFI_CERT_SHAXXX 2.Authenticated UEFI Variable 3.EFI PE/COFF Image(SHA256) Key Source: Factory, External, Mixed
Authorized Signatures  0   0   No Key		Update Append Enroll Factory Defaults or load certificates from a file: 1.Public key Certificate: a)EFI_SIGNATURE_LIST b)EFI_CERT_X509 (DER) c)EFI_CERT_RSA2048 (bin) d)EFI_CERT_SHAXXX 2.Authenticated UEFI Variable 3.EFI PE/COFF Image(SHA256) Key Source: Factory, External, Mixed

Table Continues on Next Page...

Options Summary		
Forbidden Signatures   0   0   No Key	Details	Enroll Factory Defaults or load certificates from a file: 1.Public key Certificate: a)EFI_SIGNATURE_LIST b)EFI_CERT_X509 (DER) c)EFI_CERT_RSA2048 (bin) d)EFI_CERT_SHAXXX 2.Authenticated UEFI Variable 3.EFI PE/COFF Image(SHA256) Key Source: Factory, External, Mixed
	Export	
	Update	
	Append	
	Delete	
Authorized TimeStamps  0   0   No Key	Update	Enroll Factory Defaults or load certificates from a file: 1.Public key Certificate: a)EFI_SIGNATURE_LIST b)EFI_CERT_X509 (DER) c)EFI_CERT_RSA2048 (bin) d)EFI_CERT_SHAXXX 2.Authenticated UEFI Variable 3.EFI PE/COFF Image(SHA256) Key Source: Factory, External, Mixed
	Append	
OsRecovery Signatures  0   0   No Key	Update	Enroll Factory Defaults or load certificates from a file: 1.Public key Certificate: a)EFI_SIGNATURE_LIST b)EFI_CERT_X509 (DER) c)EFI_CERT_RSA2048 (bin) d)EFI_CERT_SHAXXX 2.Authenticated UEFI Variable 3.EFI PE/COFF Image(SHA256) Key Source: Factory, External, Mixed

### 3.7 Boot – Setup Submenu

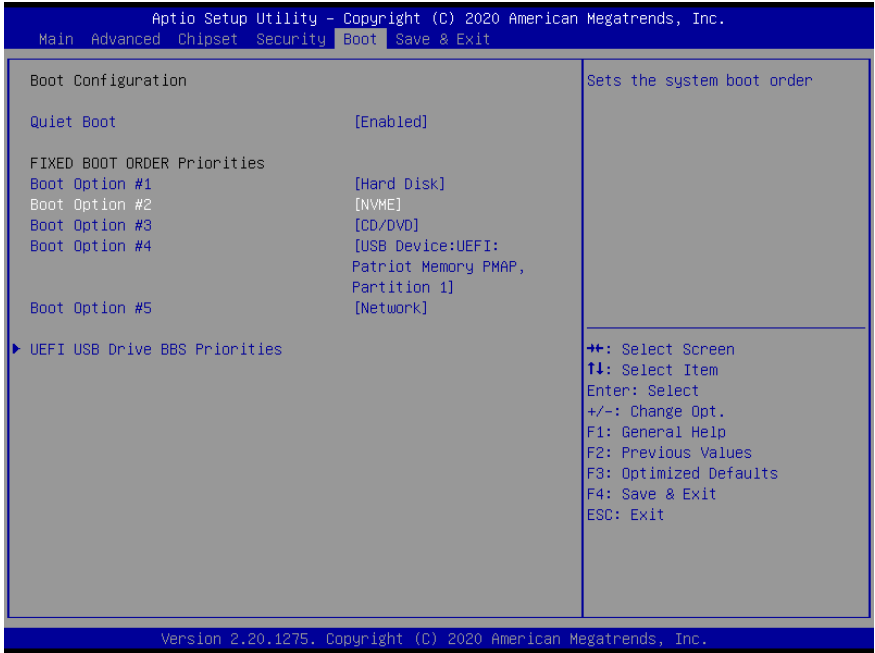

Options Summary		
Quiet Boot	Disabled	Optimal Default, Failsafe Default
	Enabled	
Enables or disables Quiet Boot option.		

### 3.8 Save & Exit – Setup Submenu

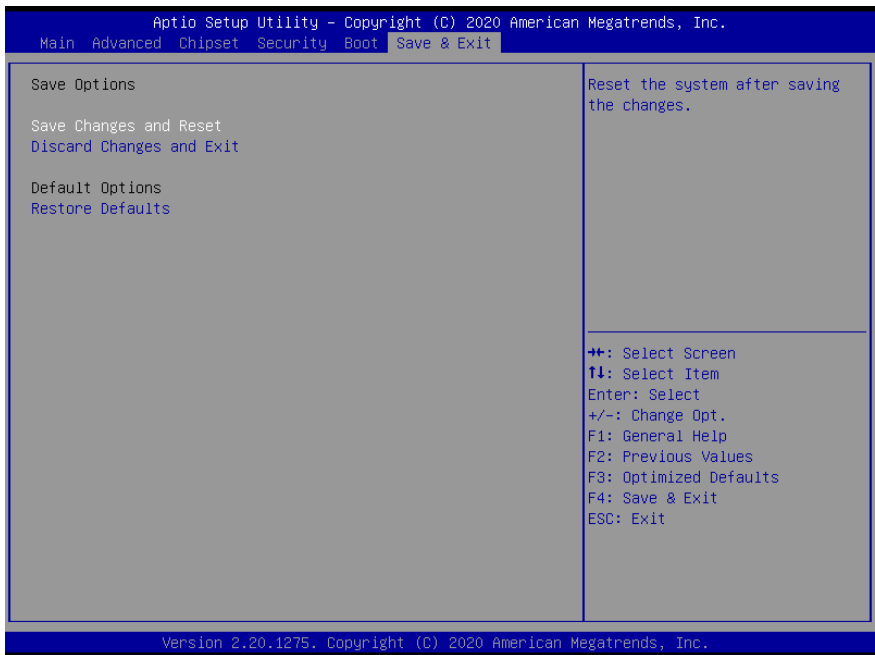

# Chapter 4

---

Drivers Installation

## 4.1 Drivers Download and Installation

---

Drivers for the BOXER-6842M can be downloaded from the product page on the AAEON website by following this link:

<https://www.aaeon.com/en/p/vision-system-box-pc-solutions-boxer-6842m>

Download the driver(s) you need and follow the steps below to install them.

### Step 1 – Install Chipset Driver

1. Open the **Step 1 - Chipset** folder and then open the OS folder
2. Run the **SetupChipset.exe** file in the folder
3. Follow the instructions
4. Drivers will be installed automatically

### Step 2 – Install Graphics Driver

1. Open the **Step 2 - Graphic** folder and then the OS folder
2. Run the **igxpin.exe** file in the folder
3. Follow the instructions
4. Drivers will be installed automatically

### Step 3 – Install ME Driver

1. Open the **Step 3 - ME** folder and then the OS folder
2. Run the **SetupME.exe** file in the folder
3. Follow the instructions
4. Drivers will be installed automatically

#### Step 4 – Install LAN Driver

1. Open the **Step 4 - LAN** folder and then the OS folder
2. Run the **PROWinx64.exe** file in the folder
3. Follow the instructions
4. Drivers will be installed automatically

#### Step 5 – Install Audio Driver

1. Open the **Step 5 – Audio** folder and then the OS folder
2. Run the **0009-64bit\_Win7\_Win8\_Win81\_Win10\_R282.exe** file in the folder
3. Follow the instructions
4. Drivers will be installed automatically

#### Step 6 – Install Intel RST Driver

1. Open the **Step 6 – Intel RST** folder and then the OS folder
2. Run the **SetupRST.exe** file in the folder
3. Follow the instructions
4. Drivers will be installed automatically

#### Step 7 – Install Serial Port Driver

1. Open the **Step 7 - Serial Port Driver (Optional)** folder and then the OS folder
2. Run the **FintekSerial.exe** file in the folder
3. Follow the instructions
4. Drivers will be installed automatically















# Appendix A

---

I/O Information

## A.1 I/O Address Map

Input/output (IO)
[0000000000000000 - 000000000000CF7] PCI Express Root Complex
[0000000000000020 - 000000000000021] Programmable interrupt controller
[0000000000000024 - 000000000000025] Programmable interrupt controller
[0000000000000028 - 000000000000029] Programmable interrupt controller
[000000000000002C - 00000000000002D] Programmable interrupt controller
[000000000000002E - 00000000000002F] Motherboard resources
[0000000000000030 - 0000000000000031] Programmable interrupt controller
[0000000000000034 - 0000000000000035] Programmable interrupt controller
[0000000000000038 - 0000000000000039] Programmable interrupt controller
[000000000000003C - 000000000000003D] Programmable interrupt controller
[0000000000000040 - 0000000000000043] System timer
[000000000000004E - 000000000000004F] Motherboard resources
[0000000000000050 - 0000000000000053] System timer
[0000000000000061 - 0000000000000061] Motherboard resources
[0000000000000063 - 0000000000000063] Motherboard resources
[0000000000000065 - 0000000000000065] Motherboard resources
[0000000000000067 - 0000000000000067] Motherboard resources
[0000000000000070 - 0000000000000070] Motherboard resources
[0000000000000080 - 0000000000000080] Motherboard resources
[0000000000000092 - 0000000000000092] Motherboard resources
[00000000000000A0 - 00000000000000A1] Programmable interrupt controller
[00000000000000A4 - 00000000000000A5] Programmable interrupt controller
[00000000000000A8 - 00000000000000A9] Programmable interrupt controller
[00000000000000AC - 00000000000000AD] Programmable interrupt controller
[00000000000000B0 - 00000000000000B1] Programmable interrupt controller
[00000000000000B2 - 00000000000000B3] Motherboard resources
[00000000000000B4 - 00000000000000B5] Programmable interrupt controller
[00000000000000B8 - 00000000000000B9] Programmable interrupt controller
[00000000000000BC - 00000000000000BD] Programmable interrupt controller
[00000000000000F0 - 00000000000000F0] Numeric data processor
[0000000000002C0 - 0000000000002C7] Communications Port (COM6)
[0000000000002D0 - 0000000000002D7] Communications Port (COM5)
[0000000000002E8 - 0000000000002EF] Communications Port (COM4)
[0000000000002F8 - 0000000000002FF] Communications Port (COM2)
[0000000000003E8 - 0000000000003EF] Communications Port (COM3)
[0000000000003F8 - 0000000000003FF] Communications Port (COM1)
[0000000000004D0 - 0000000000004D1] Programmable interrupt controller
[000000000000680 - 00000000000069F] Motherboard resources
[000000000000A00 - 000000000000A0F] Motherboard resources
[000000000000A10 - 000000000000A1F] Motherboard resources











	[000000000000A10 - 000000000000A1F]	Motherboard resources
	[000000000000A20 - 000000000000A2F]	Motherboard resources
	[000000000000D00 - 000000000000FFFF]	PCI Express Root Complex
	[000000000000164E - 000000000000164F]	Motherboard resources
	[0000000000001800 - 00000000000018FE]	Motherboard resources
	[0000000000001854 - 0000000000001857]	Motherboard resources
	[0000000000002000 - 00000000000020FE]	Motherboard resources
	[0000000000003000 - 0000000000003FFF]	Intel(R) PCI Express Root Port #8 - A33F
	[0000000000004000 - 0000000000004FFF]	Intel(R) PCI Express Root Port #7 - A33E
	[0000000000005000 - 000000000000503F]	Intel(R) UHD Graphics 630
	[0000000000005060 - 000000000000507F]	Standard SATA AHCI Controller
	[0000000000005080 - 0000000000005083]	Standard SATA AHCI Controller
	[0000000000005090 - 0000000000005097]	Standard SATA AHCI Controller
	[000000000000EFA0 - 000000000000EFBF]	Intel(R) SMBus - A323
	[000000000000FFF8 - 000000000000FFFF]	Intel(R) Active Management Technology - SOL (COM7)

## A.2 Memory Address Map

Memory Address Range	Device Name
[00000000A00000 - 0000000000BFFFFF]	PCI Express Root Complex
[0000000040000000 - 00000000403FFFFF]	Motherboard resources
[0000000090000000 - 000000009FFFFFFF]	Intel(R) UHD Graphics 630
[0000000090000000 - 00000000DFFFFFFF]	PCI Express Root Complex
[00000000A0000000 - 00000000A0FFFFFFF]	Intel(R) UHD Graphics 630
[00000000A1100000 - 00000000A111FFFFF]	Intel(R) I211 Gigabit Network Connection #2
[00000000A1100000 - 00000000A11FFFFF]	Intel(R) PCI Express Root Port #8 - A33F
[00000000A1120000 - 00000000A1123FFF]	Intel(R) I211 Gigabit Network Connection #2
[00000000A1200000 - 00000000A121FFFFF]	Intel(R) I211 Gigabit Network Connection
[00000000A1200000 - 00000000A12FFFFF]	Intel(R) PCI Express Root Port #7 - A33E
[00000000A1220000 - 00000000A1223FFF]	Intel(R) I211 Gigabit Network Connection
[00000000A1320000 - 00000000A132FFFFF]	Intel(R) USB 3.1 eXtensible Host Controller - 1.10 (Microsoft)
[00000000A1334000 - 00000000A1335FFF]	Standard SATA AHCI Controller
[00000000A1338000 - 00000000A13380FF]	Intel(R) SMBus - A323
[00000000A1339000 - 00000000A13397FF]	Standard SATA AHCI Controller
[00000000A133A000 - 00000000A133A0FF]	Standard SATA AHCI Controller
[00000000E0000000 - 00000000EFFFFFFF]	Motherboard resources
[00000000FC800000 - 00000000FE7FFFFF]	PCI Express Root Complex
[00000000FCF00000 - 00000000FCFFFFFFF]	High Definition Audio Controller
[00000000FD000000 - 00000000FD69FFFFF]	Motherboard resources
[00000000FD6A0000 - 00000000FD6AFFFFF]	Intel(R) Serial IO GPIO Host Controller - INT3450
[00000000FD6B0000 - 00000000FD6BFFFFF]	Intel(R) Serial IO GPIO Host Controller - INT3450
[00000000FD6C0000 - 00000000FD6CFFFFF]	Motherboard resources
[00000000FD6D0000 - 00000000FD6DFFFFF]	Intel(R) Serial IO GPIO Host Controller - INT3450
[00000000FD6E0000 - 00000000FD6EFFFFF]	Intel(R) Serial IO GPIO Host Controller - INT3450
[00000000FD6F0000 - 00000000FDFFFFFFF]	Motherboard resources
[00000000FE000000 - 00000000FE01FFFFF]	Motherboard resources
[00000000FE010000 - 00000000FE010FFF]	Intel(R) SPI (flash) Controller - A324
[00000000FE1D8000 - 00000000FE1DBFFF]	High Definition Audio Controller
[00000000FE1DE000 - 00000000FE1DEFFF]	Intel(R) Management Engine Interface
[00000000FE1DF000 - 00000000FE1DFFFFF]	Intel(R) Active Management Technology - SOL (COM7)
[00000000FE1E0000 - 00000000FE1FFFFFFF]	Intel(R) Ethernet Connection (7) I219-LM
[00000000FE200000 - 00000000FE7FFFFF]	Motherboard resources
[00000000FED00000 - 00000000FED003FFF]	High precision event timer
[00000000FED10000 - 00000000FED17FFF]	Motherboard resources
[00000000FED18000 - 00000000FED18FFF]	Motherboard resources
[00000000FED19000 - 00000000FED19FFF]	Motherboard resources
[00000000FED20000 - 00000000FED3FFFFF]	Motherboard resources
[00000000FED40000 - 00000000FED44FFF]	Trusted Platform Module 2.0
[00000000FED45000 - 00000000FED8FFFFF]	Motherboard resources
[00000000FED90000 - 00000000FED93FFF]	Motherboard resources
[00000000FED90000 - 00000000FED93FFF]	Motherboard resources
[00000000FEE00000 - 00000000FEEFFFFF]	Motherboard resources
[00000000FF000000 - 00000000FFFFFFFFF]	Motherboard resources

## A.3 IRQ Mapping Chart

---

▼		Interrupt request (IRQ)	
		(ISA) 0x00000000 (00)	System timer
		(ISA) 0x00000003 (03)	Communications Port (COM2)
		(ISA) 0x00000004 (04)	Communications Port (COM1)
		(ISA) 0x0000000B (11)	Communications Port (COM3)
		(ISA) 0x0000000B (11)	Communications Port (COM4)
		(ISA) 0x0000000B (11)	Communications Port (COM5)
		(ISA) 0x0000000B (11)	Communications Port (COM6)
		(ISA) 0x0000000D (13)	Numeric data processor
		(ISA) 0x0000000E (14)	Intel(R) Serial IO GPIO Host Controller - INT3450

# Appendix B

---

## Glue Removal Procedure

## B.1 Removing Glue from Your System

---

To protect components from damage and ensure proper operation out of the box, glue may have been applied to some cables or connectors to keep them in place during shipping. This glue must be removed before attempting to swap components or perform maintenance. This section details the steps needed to remove the glue.

Before performing any kind of system maintenance, ensure the system is shut down (not in sleep or hibernate mode) and the power cable has been removed. Follow steps in Chapter 2 to access the components inside.

You will need the following items for this step:

- Cotton or cotton swab
- Anti-static tweezers
- An alcohol solution that is at least 99.5% alcohol (ethanol solution or denatured alcohol). AAEON recommends using an eye dropper or a bottle with a nozzle as in the picture below:



**Step 1:** Using an eyedropper or bottle as shown above, apply a few drops of alcohol to the glue.

**Step 2:** Allow the alcohol to soak for 10 seconds, then use a cottonswab or cotton with anti-static tweezers to evenly rub the alcohol over the glue.

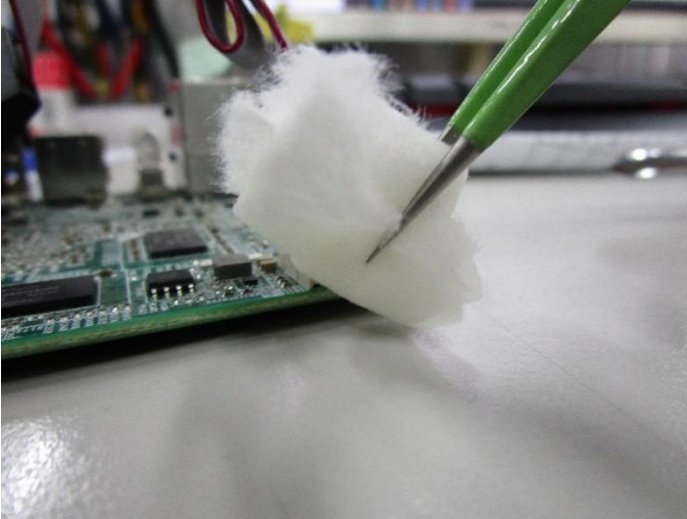

**Step 3:** Let soak for 10 more seconds, then use anti-static tweezers to remove the glue.

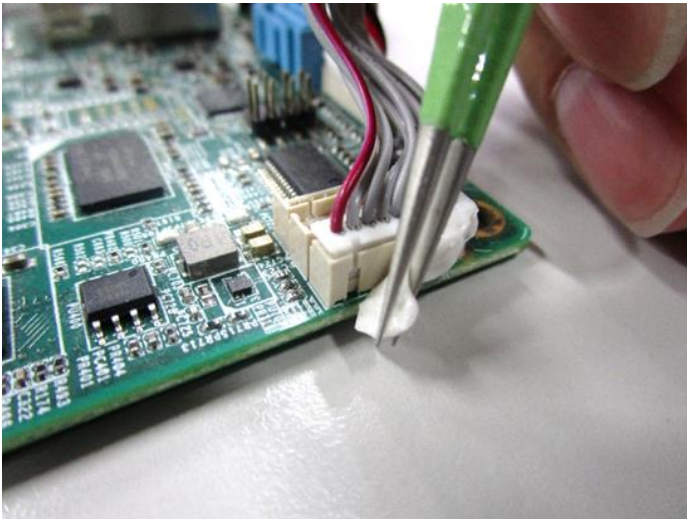

If you encounter any issues or need support, please contact your AAEON representative or visit our [Support Page](#) at AAEON.com