

BOXER-6914

Fanless Embedded Box PC
Intel® Atom™ D2550 1.86GHz
Processor
CFast™/SIM Slot
2 DIO, 14/16 COMs
2 USB 3.0, 4 USB 2.0

Copyright Notice

This document is copyrighted, 2015. All rights are reserved. The original manufacturer reserves the right to make improvements to the products described in this manual at any time without notice.

No part of this manual may be reproduced, copied, translated, or transmitted in any form or by any means without the prior written permission of the original manufacturer. Information provided in this manual is intended to be accurate and reliable. However, the original manufacturer assumes no responsibility for its use, or for any infringements upon the rights of third parties that may result from its use.

The material in this document is for product information only and is subject to change without notice. While reasonable efforts have been made in the preparation of this document to assure its accuracy, AAEON assumes no liabilities resulting from errors or omissions in this document, or from the use of the information contained herein.

AAEON reserves the right to make changes in the product design without notice to its users.

Acknowledgments

- AMI is a trademark of American Megatrends Inc.
- CFast™ is a trademark of the Compact Flash Association.
- Intel®, Atom™ are trademarks of Intel® Corporation.
- Microsoft Windows® is a registered trademark of Microsoft Corp.
- PC/AT, PS/2, and VGA are trademarks of International Business Machines Corporation.

All other product names or trademarks are properties of their respective owners.

Packing List

Before you begin operating your PC, please make sure that the following materials have been shipped:

- 1 BOXER-6914 Embedded Box PC
- 1 Phoenix Power Connector
- 4 M3 x 4mm Screws
- 4 6# -32 x 10mm Screws
- 2 Wallmount Brackets
- 1 DVD-ROM for manual (in PDF format) and Drivers

If any of these items should be missing or damaged, please contact your distributor or sales representative immediately.

Safety & Warranty

Please read the following safety instructions carefully. It is advised that you keep this manual for future references

1. Disconnect this device from any AC supply before cleaning.
2. While cleaning, use a damp cloth instead of liquid or spray detergents.
3. For any pluggable equipment, the power outlet must be installed near the device and easily accessible.
4. Keep this device away from humidity.
5. Place this device on a solid surface during installation. Dropping it or letting it fall could cause damage.
6. The openings on the device's enclosure are for dissipating heat. **DO NOT COVER THE OPENINGS.**
7. Watch out for high temperatures that may occur during system operation.
8. Make sure the voltage of the power source is correct before connecting the device to the power outlet.
9. Position the power cord so that people cannot step on it. Do not place anything over the power cord.
10. All cautions and warnings on the device should be noted.
11. If the device is not to be used for a long time, disconnect it from the power supply to avoid damage by transient over-voltage.
12. Never pour any liquid into the openings. This could cause fire or electric shock.

13. As most electronic components are sensitive to static electrical charge, be sure to ground yourself to prevent static charge when installing the internal components. Use a grounding wrist strap and contain all electronic components in any static-shielded devices.
14. **If any of the following situations arises, please contact our service personnel:**
 - i. **Damaged power cord or plug**
 - ii. **Liquid intrusion to the device**
 - iii. **Exposure to moisture**
 - iv. **Device is not working as expected or in a manner as described in this manual**
 - v. **The device is dropped or damaged**
 - vi. **Any obvious signs of damage displayed on the device**
15. **DO NOT LEAVE THIS DEVICE IN AN UNCONTROLLED ENVIRONMENT WHERE THE STORAGE TEMPERATURE IS BELOW -10° C (14°F) OR ABOVE 60° C (140° F) TO PREVENT DAMAGE.**

FCC

Warning!

This device complies with Part 15 FCC Rules. Operation is subject to the following two conditions: (1) this device may not cause harmful interference, and (2) this device must accept any interference received including interference that may cause undesired operation.

Caution:

There is a danger of explosion if the battery is incorrectly replaced. Replace only with the same or equivalent type recommended by the manufacturer. Dispose of used batteries according to the manufacturer's instructions and your local government's recycling or disposal directives.

Attention:

Il y a un risque d'explosion si la batterie est remplacée de façon incorrecte. Ne la remplacer qu'avec le même modèle ou équivalent recommandé par le constructeur. Recycler les batteries usées en accord avec les instructions du fabricant et les directives gouvernementales de recyclage.

China RoHS Requirements
产品中有害有毒物质或元素名称及含量
AAEON Boxer/ Industrial System

部件名称	有毒有害物质或元素					
	铅 (Pb)	汞 (Hg)	镉 (Cd)	六价铬 (Cr(VI))	多溴联苯 (PBB)	多溴二苯 醚(PBDE)
印刷电路板 及其电子组件	×	○	○	○	○	○
外部信号 连接器及线材	×	○	○	○	○	○
外壳	×	○	○	○	○	○
中央处理器 与内存	×	○	○	○	○	○
硬盘	×	○	○	○	○	○
电源	×	○	○	○	○	○
<p>O: 表示该有毒有害物质在该部件所有均质材料中的含量均在 SJ/T 11363-2006 标准规定的限量要求以下。</p> <p>X: 表示该有毒有害物质至少在该部件的某一均质材料中的含量超出 SJ/T 11363-2006 标准规定的限量要求。</p> <p>备注： 一、此产品所标示之环保使用期限，系指在一般正常使用状况下。 二、上述部件物质中央处理器、内存、硬盘、电源为选购品。</p>						

Contents

Chapter 1 General Information

1.1 Introduction.....	1-2
1.2 Features	1-3
1.3 Specifications	1-4
1.4 Product Overview	1-7

Chapter 2 Quick Installation Guide

2.1 List of Jumpers	2-2
2.2 List of Carrier Board Connectors.....	2-3
2.3 List of I/O Board Connectors.....	2-6
2.4 Setting Jumpers	2-5
2.5 RS-232/422 Selector for COM1 and COM2 (JP1, JP2)	2-7
2.6 Clear CMOS (JP10)	2-8
2.7 Digital I/O (CN5 – Carrier Board)	2-8
2.8 SATA Power Connector (CN24)	2-9
2.9 COM 3 – 16 (CN3, 3A, 3B, 4, 4A, 4B, 5A, 5B, 6A, 6B, 29,30).....	2-9

Chapter 3 AMI BIOS Setup

3.1 System Test and Initialization.	3-2
3.2 AMI BIOS Setup	3-3

Chapter 4 Driver Installation

4.1 Installation	4-3
------------------------	-----

Appendix A Programming The Watchdog Timer

A.1 Watchdog Timer Initial Program	A-2
--	-----

Appendix B I/O Information

B.1 I/O Address MapB-2
B.2 Memory Address MapB-5
B.3 IRQ Mapping ChartB-6
B.4 DMA Channel AssignmentsB-10

Appendix C Programming the Digital I/O

C.1 DIO Programming..... C-2

Chapter

1

**General
Information**

1.1 Introduction

Due to the growing popularity from the IPC market, AAEON proudly introduces the newest entry in Boxer series, BOXER-6914. Being a control center, the BOXER-6914 is suitable for Machine Control, Data Processing, Fleet Management, Data Management. BOXER-6914 equips a high efficiency heat conduction mechanism.

The BOXER-6914 has flexible expansion capabilities such as two USB 3.0 ports and four USB 2.0 ports, two Digital I/Os, 14/16 COM ports, and 2 Full-size Mini-PCle slots.

Rugged Design for Harsh Environment

The BOXER-6914 is designed for harsh environment with the following features: It can withstand strong vibrations of up to 3 g rms, and is well suited for high-vibration environment with the anti-vibration hard drive device option. In addition, the BOXER-6914 offers low power consumption system that while operating in ambient temperatures ranging from -20° to 65°C with the Intel® Atom™ D2550 processor.

The BOXER-6914 is a standalone high performance box PC designed for long-life operation and with high reliability. It can replace traditional methods and become the mainstream controller for the multimedia entertainment market.

1.2 Features

- Fanless Design
- Intel® Atom™ D2550 Processor
- Intel® NM10 Chipset
- Gigabit Ethernet, RJ-45 x 2
- DVI-D x 1
- SATA 3.0 Gb/s x 1, CFAST™ Slot x 1
- USB 3.0 x 2, USB 2.0 x 4, COM x 14/16, DI/O x 2
- 2.5" SATA HDD Bay x 1, CFAST™ Slot x 1
- Full-size Mini-PCIe slots

1.3 Specifications

● CPU		Intel® Atom™ D2550 Processor, 1.86 GHz
● Chipset		Intel® NM10
● System Memory		DDR3 800/1066 SODIMM x 1, Max. 4 GB
● Display Interface	VGA	DB-15 x 1
	DVI	DVI-D x 1
	HDMI	—
	Others	—
● Storage Device	SSD	CFast™ slot x 1
	HDD	2.5" SATA HDD Bay x 1
	Others	—
● Network	LAN	Gigabit Ethernet
	Wireless	Optional by MiniCard module
● Front I/O	USB Host	USB 2.0 x 2
	LAN	—
	Serial Port	—
	DIO	—
	Audio	—
	KB/MS	—
	Others	Power On/Off button x 1, 2-pin Remote Power on/off terminal block x 1, CFast™ slot x 1, SIM slot, Line-out x 1

- **Rear I/O**
 - USB Host USB 3.0 x 2, USB 2.0 x 2
 - LAN RJ-45 x 2 for Gigabit Ethernet
 - Serial Port DB-9 x 2 for RS-232/422/485
(cableless)
DB-9 x 12 for RS-232 (cableless)
DB-9 x 2 for RS-232 (optional by cable)
 - DIO Programmable 30-channel digital I/O
 - Audio —
 - KB/MS —
 - Others DC-in 3-pin terminal block (9~30V)
Antenna hole x 2
DB-15 x 1 for VGA
DVI-D x 1
- **Expansion**
 - PCI-E[x1] Mini PCI-E Full-Size Card x 2
 - PCI —
 - Mini Card —
 - Mini PCI —
 - Others —
- **Indicator**
 - Front HDD LED x 1
System Power On LED x 1
 - Rear —
- **Power Requirement** DC-in 3-pin terminal block (9~30V)
- **System Cooling** Passive cooling
- **Mounting** Wall-mount
- **Operating Temperature** -4°F ~ 140°F (-20°C ~ 60°C). Ambient

		w/ airflow, with wide-temp CFast™ & RAM -4°F ~ 131°F (-20°C ~ 55°C). Ambient w/ airflow, with wide-temp HDD & RAM -4°F ~ 131°F (-20°C ~ 55°C). Without airflow, with wide-temp CFast™ & RAM -4°F ~ 122°F (-20°C ~ 50°C). Without airflow, with wide-temp CFast™ & RAM -4°F ~ 158°F (-20°C ~ 70°C)
● Storage Temperature		
● Anti-Vibration		5 g rms/ 5~500 Hz/ operation-CFast™; 1 g rms/ 5~500 Hz/ operation-HDD
● Anti-Shock		50 G peak acceleration (11 msec. duration) –CFast™ 20 G peak acceleration (11 msec. duration) –HDD
● Certification	EMC Safety	CE/FCC Class A —
● Dimension (W x H x D)		13.10" x 5.39" x 7.48" (332.8mm x 136.8mm x 190mm)
● Gross Weight		4.4kg
● Net Weight		2.6kg
● OS Support		Windows® XP 32-bit, Windows® 7 32-bit, Linux Fedora 32-bit

1.4 Product Overview

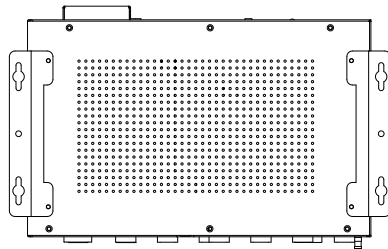
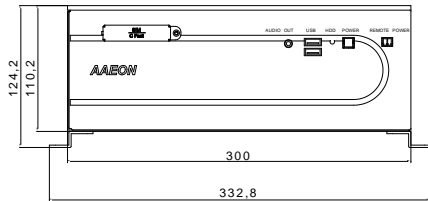
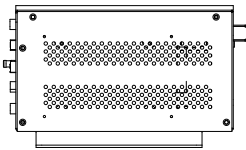
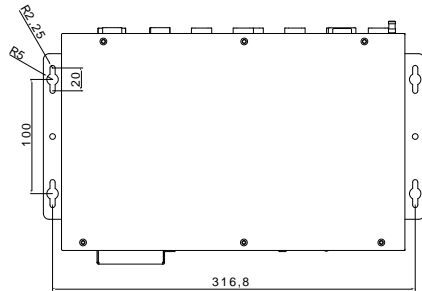

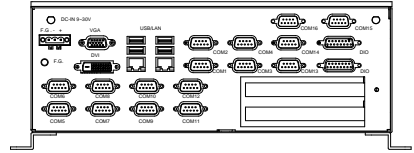
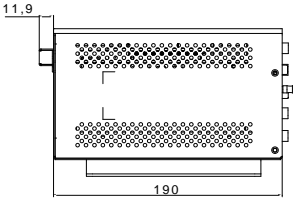
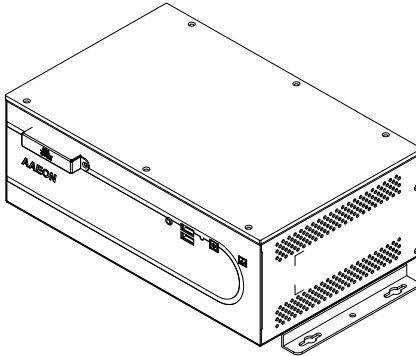

Chapter

2

**Quick
Installation
Guide**

2.1 List of Jumpers

The board has a number of jumpers that allow you to configure your system to suit your application.

The table below shows the function of each of the board's jumpers:

Label	Function
JP1	RS-232/422/485 Selector (COM2)
JP2	RS-232/422/485 Selector (COM1)
JP10	Clear CMOS

Note: By default, RS-232/422/485 to be selected via BIOS settings

2.2 List of Carrier Board Connectors

The carrier board has a number of connectors that allow you to configure your system to suit your application.

The table below shows the function of each of the connectors:

Label	Function
CN1	DCIN
CN2	COM1/2 Port
CN3	COM 3/4 Port
CN4	COM 13/14 Port
CN5	Digital I/O
CN6	USB 3.0 x 2 / LAN1 Connector
CN7	USB 2.0 x 2 / LAN2 Connector
CN8	Extender I/O 3
CN9	COM port Extender I/O 1
CN10	COM port Extender I/O 2
CN11	LPC Debug port
CN12	PCIe x 1 Riser Connector 1
CN14	MiniCard Connector (with onboard SIM)
CN15	MiniCard Connector (with onboard SIM)
CN16	SATA 2.0 Connector
CN17	PCIe x 1 Riser Connector 2
CN21	USB 2.0 Connector x 2
CN22	Audio Connector
CN23	Line out Connector
CN24	SATA Power Connector

CN26	Remote Power SW
CN27, CN28	COM Express Type 6 Connector
CN29	COM 15 Connector
CN30	COM 16 Connector
CN31	CFast Connector
DVI + VGA	DVI-D & VGA Connector

Note 1: Wake-on-LAN supported in LAN1 only

Note 2: USB 3.0 drives must be installed before USB 3.0 ports can be used

Note 3: Max. resolution for DVI on Windows XP is 1920 x 1200

2.3 List of I/O Board Connectors

The I/O board has a number of connectors that allow you to configure your system to suit your application.

The table below shows the function of each of the connectors:

Label	Function
CN3A	COM 5
CN3B	COM 6
CN4A	COM 7
CN4B	COM 8
CN5A	COM 9
CN5B	COM 10
CN6A	COM 11
CN6B	COM 12

2.4 Setting Jumpers

You configure your card to match the needs of your application by setting jumpers. A jumper is the simplest kind of electric switch. It consists of two metal pins and a small metal clip (often protected by a plastic cover) that slides over the pins to connect them. To “close” a jumper you connect the pins with the clip.

To “open” a jumper you remove the clip. Sometimes a jumper will have three pins, labeled 1, 2 and 3. In this case you would connect either pins 1 and 2 or 2 and 3.

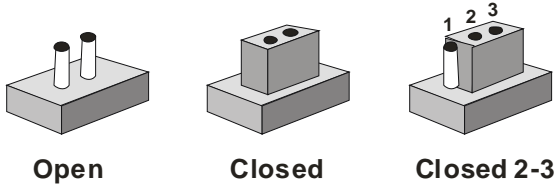

A pair of needle-nose pliers may be helpful when working with jumpers.

If you have any doubts about the best hardware configuration for your application, contact your local distributor or sales representative before you make any change.

In general, you simply need a standard cable to make most connections.

2.5 RS-232/422 Selector for COM1 and COM2 (JP1, JP2)

JP1,JP2	Connection
RS-232	1-2 close, 3-4 open
RS-422	1-2, 3-4 close

RS-232

Pin	Signal	Pin	Signal
1	DCD	6	DSR
2	RXD	7	RTS
3	TXD	8	CTS
4	DTR	9	RI
5	GND		

RS-422

Pin	Signal	Pin	Signal
1	TXD-	6	NC
2	TXD+	7	NC
3	RXD-	8	NC
4	RXD+	9	NC
5	GND		

RS-485

Pin	Signal	Pin	Signal
1	D-	6	NC
2	D+	7	NC
3	NC	8	NC
4	NC	9	NC
5	GND		

2.6 Clear CMOS (JP10)

JP10	Function
1-2	Normal (Default)
2-3	Clear CMOS

2.7 Digital I/O (CN5 – Carrier Board)

CN5A (Carrier board)

Pin	Signal	Pin	Signal
1	DIO0-0	9	DIO1-0
2	DIO0-1	10	DIO1-1
3	DIO0-2	11	DIO1-2
4	DIO0-3	12	DIO1-3
5	DIO0-4	13	DIO1-4
6	DIO0-5	14	DIO1-5
7	DIO0-6	15	DIO1-6
8	DIO0-7		

CN5B (Carrier board)

Pin	Signal	Pin	Signal
1	DIO1-7	9	DIO2-7
2	DIO2-0	10	DIO3-0
3	DIO2-1	11	DIO3-1
4	DIO2-2	12	DIO3-2
5	DIO2-3	13	DIO3-3
6	DIO2-4	14	DIO3-4
7	DIO2-5	15	DIO3-5
8	DIO2-6		

2.8 SATA Power Connector (CN24)

Pin	Function
1	+12V
2	GND
3	GND
4	+5V

2.9 COM 3 - 16 (CN3, 3A, 3B, 4, 4A, 4B, 5A, 5B, 6A, 6B, 29, 30)

RS-232

Pin	Signal	Pin	Signal
1	DCD	6	DSR
2	RXD	7	RTS
3	TXD	8	CTS
4	DTR	9	RI
5	GND		

Chapter

3

**AMI
BIOS Setup**

3.1 System Test and Initialization

These routines test and initialize board hardware. If the routines encounter an error during the tests, you will either hear a few short beeps or see an error message on the screen. There are two kinds of errors: fatal and non-fatal. The system can usually continue the boot up sequence with non-fatal errors.

System configuration verification

These routines check the current system configuration stored in the CMOS memory and BIOS NVRAM. If system configuration is not found or system configuration data error is detected, system will load optimized default and re-boot with this default system configuration automatically.

There are four situations in which you will need to setup system configuration:

1. You are starting your system for the first time
2. You have changed the hardware attached to your system
3. The system configuration is reset by Clear-CMOS jumper
4. The CMOS memory has lost power and the configuration information has been erased.

The BOXER-6914 CMOS memory has an integral lithium battery backup for data retention. However, you will need to replace the complete unit when it finally runs down.

3.2 AMI BIOS Setup

AMI BIOS ROM has a built-in Setup program that allows users to modify the basic system configuration. This type of information is stored in battery-backed CMOS RAM and BIOS NVRAM so that it retains the Setup information when the power is turned off.

Entering Setup

Power on the computer and press or <F2> immediately. This will allow you to enter Setup.

Main

Set the date, use tab to switch between date elements.

Advanced

Enable/disable boot option for legacy network devices.

Chipset

Host bridge parameters.

Boot

Enables/disables quiet boot option.

Security

Set setup administrator password.

Save & Exit

Exit system setup after saving the changes.

Setup Menu

Setup submenu: Main

Aptio Setup Utility - Copyright (C) 2011 American Megatrends, Inc.		
Main Advanced Chipset Boot Security Save & Exit		
BIOS Information BOXER-6914 R1.0(B914AM10) (03/04/2015)		Set the Date. Use Tab to switch between Date elements.
BIOS Vendor Core Version Compliancy	American Megatrends 4.6.5.3 UEFI 2.3; PI 1.2	
Firmware VENDOR Firmware Information Firmware Version Build Date	AAEDN Mother Board 6913AE11 2014/5/16	++: Select Screen ↑↓: Select Item Enter: Select +/-: Change Opt. F1: General Help F2: Previous Values F3: Optimized Defaults F4: Save & Exit ESC: Exit
System Date System Time	[Thu 01/01/2009] [00:54:05]	
Access Level	Administrator	
Version 2.14.1219. Copyright (C) 2011 American Megatrends, Inc.		

Setup submenu: Advanced

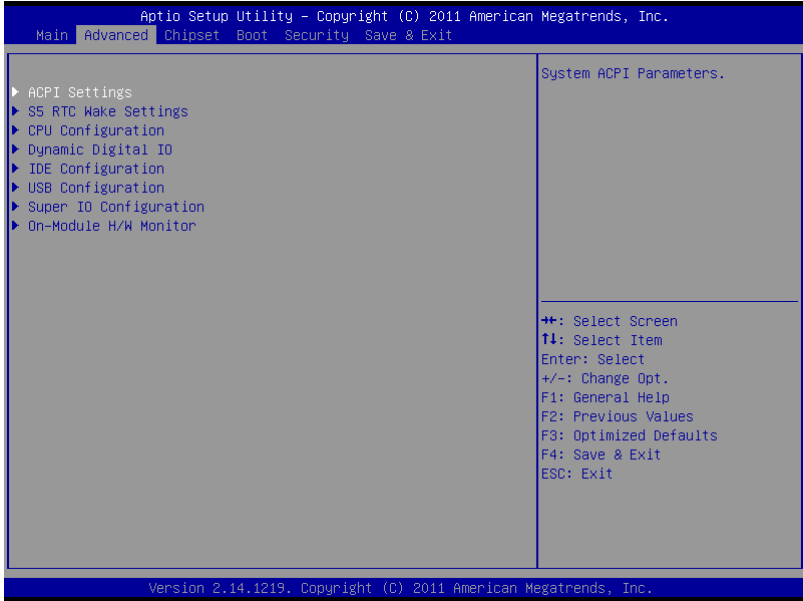

CPU Configuration

Aptio Setup Utility - Copyright (C) 2011 American Megatrends, Inc.

Advanced

CPU Configuration		Enabled for Windows XP and Linux (OS optimized for Hyper-Threading Technology) and Disabled for other OS (OS not optimized for Hyper-Threading Technology).
Intel(R) Atom(TM) CPU D2550 @ 1.86GHz		
EMT64	Not Supported	++: Select Screen ↑↓: Select Item Enter: Select +/-: Change Opt. F1: General Help F2: Previous Values F3: Optimized Defaults F4: Save & Exit ESC: Exit
Processor Speed	1865 MHz	
System Bus Speed	533 MHz	
Ratio Status	14	
Actual Ratio	14	
System Bus Speed	533 MHz	
Processor Stepping	30661	
Microcode Revision	269	
L1 Cache RAM	2x56 k	
L2 Cache RAM	2x512 k	
Processor Core	Dual	
Hyper-Threading	Supported	
Hyper-Threading	[Enabled]	

Version 2.14.1219. Copyright (C) 2011 American Megatrends, Inc.

Options summary:

Hyper-Threading	Disabled	
	Enabled	Optimal Default, Failsafe Default

IDE Configuration (IDE)

Aptio Setup Utility - Copyright (C) 2011 American Megatrends, Inc.

Advanced

SATA Port0	TOSHIBA MQ01AB (320.0	SATA Ports (0-3) Device Names if Present and Enabled.
SATA Port1	Not Present	
SATA Controller(s)	[Enabled]	
Configure SATA as	[IDE]	

++: Select Screen
 ↑↓: Select Item
 Enter: Select
 +/-: Change Opt.
 F1: General Help
 F2: Previous Values
 F3: Optimized Defaults
 F4: Save & Exit
 ESC: Exit

Version 2.14.1219. Copyright (C) 2011 American Megatrends, Inc.

Options summary:

SATA Controllers	Enable	Optimal Default, Failsafe Default
	Disable	
En/Disable SATA Controller		
SATA Mode	IDE	Optimal Default, Failsafe Default
	AHCI	

USB Configuration

Aptio Setup Utility - Copyright (C) 2011 American Megatrends, Inc.

Advanced

<p>USB Configuration</p> <p>USB Devices: 1 Drive, 1 Keyboard</p> <p>Legacy USB Support [Enabled]</p>	<p>Enables Legacy USB support. AUTO option disables legacy support if no USB devices are connected. DISABLE option will keep USB devices available only for EFI applications.</p> <hr/> <p> ++: Select Screen ↑↓: Select Item Enter: Select +/-: Change Opt. F1: General Help F2: Previous Values F3: Optimized Defaults F4: Save & Exit ESC: Exit </p>
--	---

Version 2.14.1219. Copyright (C) 2011 American Megatrends, Inc.

Options summary:

Legacy USB Support	Enable	Optimal Default, Failsafe Default
	Disable	

Hardware Monitor

Aptio Setup Utility - Copyright (C) 2011 American Megatrends, Inc.

Advanced

Pc Health Status	
Chassis Temperature(CPU)	: +38 %
Chassis Temperature	: +37 %
+1.8V	: +1.809 V
+5V	: +4.902 V
+3.3V	: +3.296 V
VMEM	: +1.507 V
+1.05V	: +1.061 V
VGFX	: +1.126 V

++: Select Screen
 ↑↓: Select Item
 Enter: Select
 +/-: Change Opt.
 F1: General Help
 F2: Previous Values
 F3: Optimized Defaults
 F4: Save & Exit
 ESC: Exit

Version 2.14.1219. Copyright (C) 2011 American Megatrends, Inc.

Dynamic Digital IO Configuration

Aptio Setup Utility - Copyright (C) 2011 American Megatrends, Inc.

Advanced

GPIO_00 Direction	[Output]	▲ Set GPIO as Input or Output ⇅: Select Screen ↑↓: Select Item Enter: Select +/-: Change Opt. F1: General Help F2: Previous Values F3: Optimized Defaults F4: Save & Exit ESC: Exit
Output Level	[Hi]	
GPIO_01 Direction	[Output]	
Output Level	[Hi]	
GPIO_02 Direction	[Output]	
Output Level	[Hi]	
GPIO_03 Direction	[Output]	
Output Level	[Hi]	
GPIO_04 Direction	[Output]	
Output Level	[Hi]	
GPIO_05 Direction	[Output]	
Output Level	[Hi]	
GPIO_06 Direction	[Output]	
Output Level	[Hi]	
GPIO_07 Direction	[Output]	
Output Level	[Hi]	
GPIO_10 Direction	[Output]	
Output Level	[Hi]	
GPIO_11 Direction	[Output]	
Output Level	[Hi]	
GPIO_12 Direction	[Output]	
Output Level	[Hi]	
GPIO_13 Direction	[Output]	

Version 2.14.1219. Copyright (C) 2011 American Megatrends, Inc.

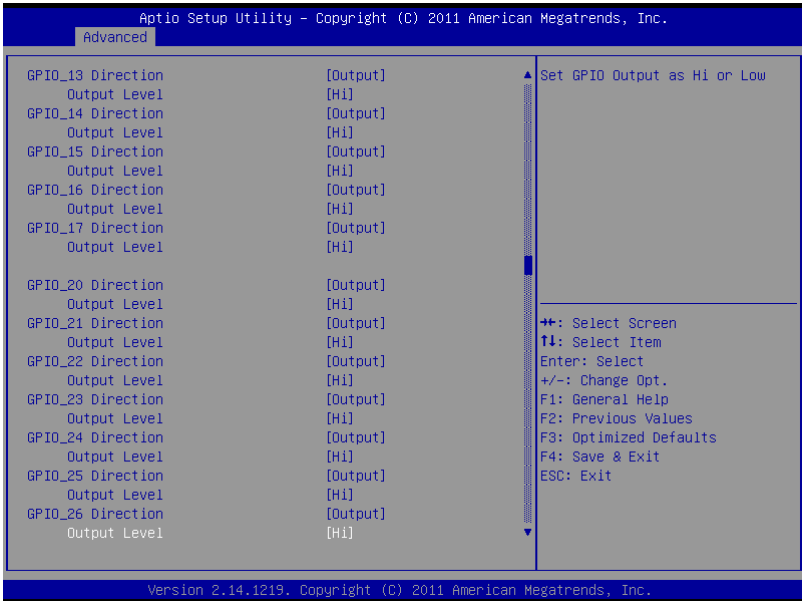

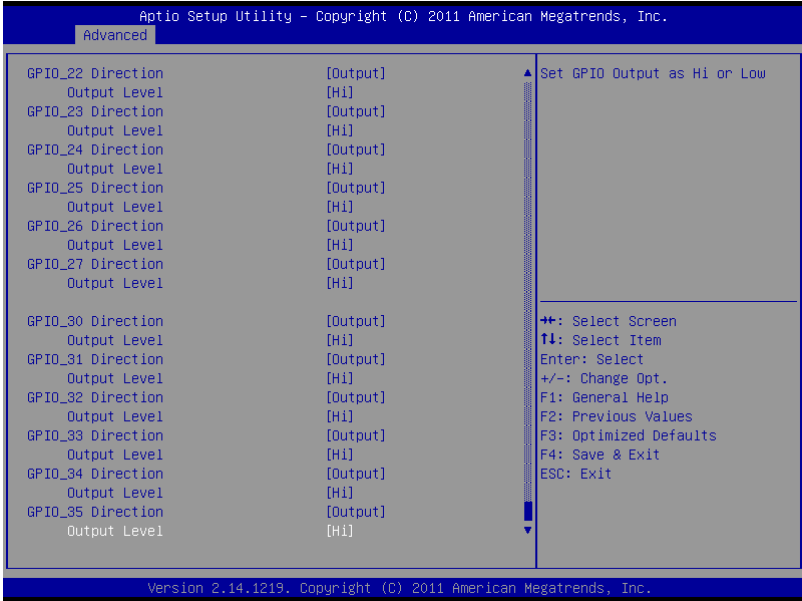

Options summary:

GPIO[35:0] Direction	Input	
	Output	Optimal Default, Failsafe Default
Set GPI[35:0] as Input or Output		
GPO[35:0] Output Level	Hi	Optimal Default, Failsafe Default
	Low	

Power Management

Aptio Setup Utility - Copyright (C) 2011 American Megatrends, Inc.

Chipset

PCI Express Port 0	[Enabled]	Select the power type used on the system
PCI Express Port 1	[Enabled]	
PCI Express Port 2	[Auto]	
PCI Express Port 3	[Auto]	
Azalia Controller	[HD Audio]	
Power Management Configuration		
Power Mode	[ATX Type]	
PWRON After PWR-Fail	[Last State]	

++: Select Screen
 ↑↓: Select Item
 Enter: Select
 +/-: Change Opt.
 F1: General Help
 F2: Previous Values
 F3: Optimized Defaults
 F4: Save & Exit
 ESC: Exit

Version 2.14.1219. Copyright (C) 2011 American Megatrends, Inc.

Options summary:

Power Mode	ATX Type	Optimal Default, Failsafe Default
	AT Type	
Select power supply mode.		
Restore on Power Loss	Last State	Optimal Default, Failsafe Default
	Power On	
	Power Off	

PCI Express Port Configuration

Aptio Setup Utility - Copyright (C) 2011 American Megatrends, Inc.

Chipset

PCI Express Port 0	[Enabled]	Select the power type used on the system
PCI Express Port 1	[Enabled]	
PCI Express Port 2	[Auto]	
PCI Express Port 3	[Auto]	
Azalia Controller		[HD Audio]
Power Management Configuration		
Power Mode	[ATX Type]	
PWRON After PWR-Fail	[Last State]	

++: Select Screen
 ↑↓: Select Item
 Enter: Select
 +/-: Change Opt.
 F1: General Help
 F2: Previous Values
 F3: Optimized Defaults
 F4: Save & Exit
 ESC: Exit

Version 2.14.1219. Copyright (C) 2011 American Megatrends, Inc.

Options summary:

Use This Device	Disabled	Optimal Default, Failsafe Default
	Enabled	
	Auto	
En/Disable/Auto PCI Express Port		
PCI Express Port 0	Disable	Optimal Default, Failsafe Default
	Enable	
PCI Express Port 1	Disabled	Optimal Default, Failsafe Default
	Enabled	
PCI Express Port 2	Disabled	Optimal Default, Failsafe Default
	Enabled	
	Auto	
PCI Express Port 3	Disabled	Optimal Default, Failsafe Default
	Enabled	
	Auto	

Setup submenu: Chipset

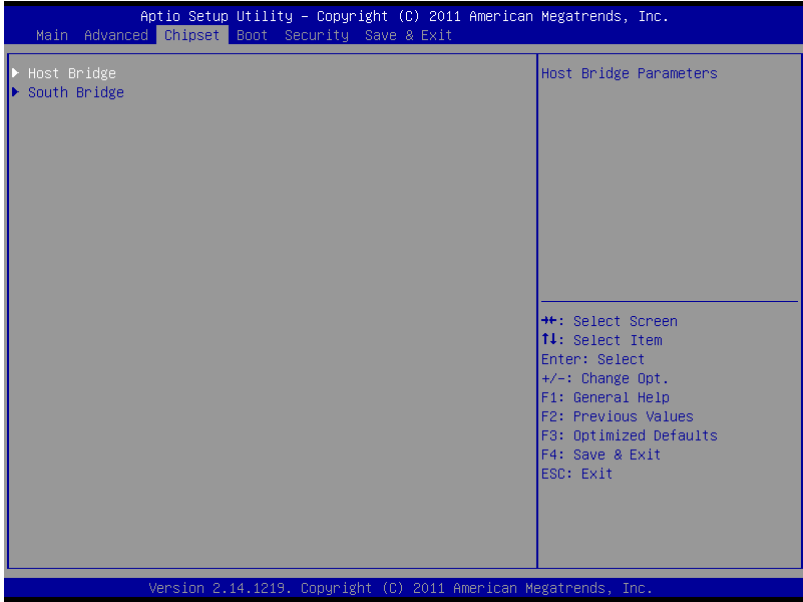

Host Bridge

Aptio Setup Utility - Copyright (C) 2011 American Megatrends, Inc.

Chipset

<p>▶ Intel IGD Configuration</p> <p>***** Memory Information *****</p> <table style="width: 100%; border: none;"> <tr> <td style="padding-right: 20px;">Memory Frequency</td> <td>1067 MHz(DDR3)</td> </tr> <tr> <td>Total Memory</td> <td>2048 MB</td> </tr> <tr> <td>DIMM#1</td> <td>2048 MB</td> </tr> </table>	Memory Frequency	1067 MHz(DDR3)	Total Memory	2048 MB	DIMM#1	2048 MB	<p>Config Intel IGD Settings.</p> <hr/> <p> ++: Select Screen ↑↓: Select Item Enter: Select +/-: Change Opt. F1: General Help F2: Previous Values F3: Optimized Defaults F4: Save & Exit ESC: Exit </p>
Memory Frequency	1067 MHz(DDR3)						
Total Memory	2048 MB						
DIMM#1	2048 MB						

Version 2.14.1219. Copyright (C) 2011 American Megatrends, Inc.

South Bridge

Aptio Setup Utility - Copyright (C) 2011 American Megatrends, Inc.

Chipset

PCI Express Port 0	[Enabled]	Select the power type used on the system
PCI Express Port 1	[Enabled]	
PCI Express Port 2	[Auto]	
PCI Express Port 3	[Auto]	
Azalia Controller	[HD Audio]	
Power Management Configuration		
Power Mode	[ATX Type]	
PWRON After PWR-Fail	[Last State]	

++: Select Screen
 ↑↓: Select Item
 Enter: Select
 +/-: Change Opt.
 F1: General Help
 F2: Previous Values
 F3: Optimized Defaults
 F4: Save & Exit
 ESC: Exit

Version 2.14.1219. Copyright (C) 2011 American Megatrends, Inc.

Security

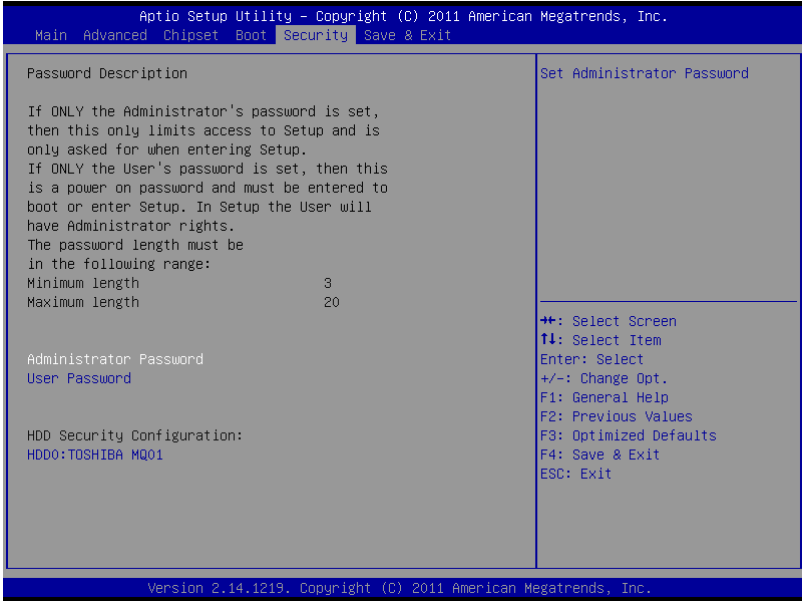

Change User/Supervisor Password

You can install a Supervisor password, and if you install a supervisor password, you can then install a user password. A user password does not provide access to many of the features in the Setup utility.

If you highlight these items and press Enter, a dialog box appears which lets you enter a password. You can enter no more than six letters or numbers. Press Enter after you have typed in the password. A second dialog box asks you to retype the password for confirmation. Press Enter after you have retyped it correctly. The password is required at boot time, or when the user enters the Setup utility.

Removing the Password

Highlight this item and type in the current password. At the next dialog box press Enter to disable password protection.

Setup submenu: Boot

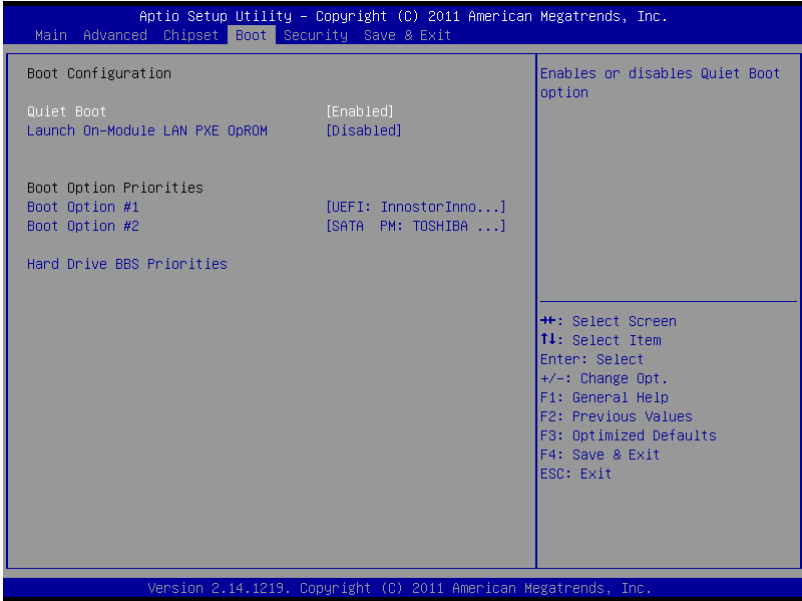

Options summary:

Quiet Boot	Disabled	Default
	Enabled	
En/Disable showing boot logo.		
Option ROM Messages	Force BIOS	Default
	Keep Current	
Set display mode for Option ROM		
Launch On-Module LAN PXE OpROM	Disabled	Default
	Enabled	
En/Disable Legacy Boot Option		

Setup submenu: Exit

Aptio Setup Utility - Copyright (C) 2011 American Megatrends, Inc.	
Main Advanced Chipset Boot Security Save & Exit	
Save Changes and Exit Discard Changes and Exit Save Changes and Reset Discard Changes and Reset Save Options Save Changes Discard Changes Restore Defaults Save as User Defaults Restore User Defaults Boot Override UEFI: InnostorInnstor 1.00 SATA PM: TOSHIBA MQ01ABF032 Launch EFI Shell from filesystem device	Exit system setup after saving the changes. ++: Select Screen ↑↓: Select Item Enter: Select +/-: Change Opt. F1: General Help F2: Previous Values F3: Optimized Defaults F4: Save & Exit ESC: Exit
Version 2.14.1219. Copyright (C) 2011 American Megatrends, Inc.	

Chapter

4

Driver Installation

The BOXER-6914 comes with a driver disk that contains all drivers and utilities that can help you setup your product.

Insert the disk and the installation guide will start automatically. If it doesn't, please follow the sequence below to install the drivers.

Follow the sequence below to install the drivers:

- Step 1 – Install Chipset Driver
- Step 2 – Install VGA Driver
- Step 3 – Install LAN Driver
- Step 4 – Install Audio Driver
- Step 5 – Install USB 3.0 Driver
- Step 6 – Install AHCI Driver
- Step 7 – Install F81216 Patch
- Step 8 – Install F81512 Driver

Please read following instructions for detailed installations.

4.1 Installation:

Insert the BOXER-6914 driver disk into the disk drive. And install the drivers from Step 1 to Step 8 in order.

Step 1 – Install Chipset Driver

1. Open the **Step 1 - Chipset** folder and open the ***infinst_autol.exe*** file
2. Follow the instructions
3. Drivers will be installed automatically

Step 2 – Install VGA Driver

1. Open the **Step 2 - VGA** folder and select your OS

For Windows 7:

1. Open **Setup.exe**
2. Follow the instructions
3. Drivers will be installed automatically

For Windows XP:

1. Open and install ***dotnetfx35.exe***
2. After installation completes, open ***WindowsDriverSETUP.cmd***
3. Follow the instructions
4. Drivers will be installed automatically

Step 3 – Install LAN Driver

1. Open the **Step 3 - LAN** folder and select your OS
2. Open the **.exe** file in the folder
3. Follow the instructions
4. Drivers will be installed automatically

Step 4 – Install Audio Driver

1. Open the **Step 4 - AUDIO** folder and select your OS
2. Open **setup.exe**
3. Follow the instructions
4. Drivers will be installed automatically

Step 5 – Install USB3.0 Driver

1. Open the **Step 5 – USB3.0** folder and open **RENESAS-USB3-Host-Driver-21160-setup** file
2. Follow the instructions
3. Drivers will be installed automatically

Step 6 – Install AHCI Driver

1. Open the **Step 6 - AHCI** folder and select your OS
2. Open **setup.exe**
3. Follow the instructions
4. Drivers will be installed automatically

Step 7 – Install F81216 Patch

1. Open the **Step 7 – F81216 Patch** folder and open the **setup.exe** file
2. Follow the instructions
3. Drivers will be installed automatically

Step 8 – Install F81512 Driver

1. Open the **Step 8 – F81512 Driver** folder and open the **setup.exe** file
2. Follow the instructions
3. Drivers will be installed automatically

Appendix

A

Programming the Watchdog Timer

A.1 Watchdog Timer Initial Program

```
ND_PROCESS MACRO
```

```
    mov ah, 4ch
```

```
    int 21h
```

```
    ENDM
```

```
;***** Code Segment *****
```

```
    .MODEL SMALL
```

```
    .CODE
```

```
begin:
```

```
    ; Set BRAM_Device as 0xA0
```

```
    mov dx, 284h
```

```
    mov al, 10h
```

```
    out dx, al
```

```
    inc dx
```

```
    mov al, 0A8h
```

```
    out dx, al
```

```
;Set BRAM_Command as 0x00 (GPIO device input/output  
;access)
```

```
    dec dx
```

```
    mov al, 11h
```

```
    out dx, al
```

```
    inc dx
```

```
    mov al, 00h
```

```
    out dx, al
```

```
    ; Set BRAM_Data2 as 0xFF (WDT Counter)
```

```
    dec dx
```

```
    mov al, 15h
```

```
    out dx, al
```

```
    inc dx
```

```
    mov al, 3Ch    ;60 Sec
```

```
out dx, al
```

```
; Set BRAM_Ctrl_Sts as 0x10 (Read & Start)
```

```
dec dx
```

```
mov al, 12h
```

```
out dx, al
```

```
inc dx
```

```
mov al, 30h
```

```
out dx, al
```

```
exit: END_PROCESS
```

































Appendix





























B

I/O Information

B.1 I/O Address Map

Input/output (IO)	
[00000000 - 0000001F]	Direct memory access controller
[00000000 - 00000CF7]	PCI bus
[00000010 - 0000001F]	Motherboard resources
[00000020 - 00000021]	Programmable interrupt controller
[00000022 - 0000003F]	Motherboard resources
[00000024 - 00000025]	Programmable interrupt controller
[00000028 - 00000029]	Programmable interrupt controller
[0000002C - 0000002D]	Programmable interrupt controller
[0000002E - 0000002F]	Motherboard resources
[00000030 - 00000031]	Programmable interrupt controller
[00000034 - 00000035]	Programmable interrupt controller
[00000038 - 00000039]	Programmable interrupt controller
[0000003C - 0000003D]	Programmable interrupt controller
[00000040 - 00000043]	System timer
[00000044 - 0000005F]	Motherboard resources
[0000004E - 0000004F]	Motherboard resources
[00000050 - 00000053]	System timer
[00000061 - 00000061]	Motherboard resources
[00000062 - 00000063]	Motherboard resources
[00000063 - 00000063]	Motherboard resources
[00000065 - 00000065]	Motherboard resources
[00000065 - 0000006F]	Motherboard resources
[00000067 - 00000067]	Motherboard resources
[00000070 - 00000070]	Motherboard resources
[00000070 - 00000077]	System CMOS/real time clock
[00000072 - 0000007F]	Motherboard resources
[00000080 - 00000080]	Motherboard resources
[00000080 - 00000080]	Motherboard resources
[00000081 - 00000091]	Direct memory access controller
[00000084 - 00000086]	Motherboard resources
[00000088 - 00000088]	Motherboard resources
[0000008C - 0000008E]	Motherboard resources

	[00000090 - 0000009F]	Motherboard resources
	[00000092 - 00000092]	Motherboard resources
	[00000093 - 0000009F]	Direct memory access controller
	[000000A0 - 000000A1]	Programmable interrupt controller
	[000000A2 - 000000BF]	Motherboard resources
	[000000A4 - 000000A5]	Programmable interrupt controller
	[000000A8 - 000000A9]	Programmable interrupt controller
	[000000AC - 000000AD]	Programmable interrupt controller
	[000000B0 - 000000B1]	Programmable interrupt controller
	[000000B2 - 000000B3]	Motherboard resources
	[000000B4 - 000000B5]	Programmable interrupt controller
	[000000B8 - 000000B9]	Programmable interrupt controller
	[000000BC - 000000BD]	Programmable interrupt controller
	[000000C0 - 000000DF]	Direct memory access controller
	[000000E0 - 000000EF]	Motherboard resources
	[000000F0 - 000000F0]	Numeric data processor
	[00000284 - 00000293]	Motherboard resources
	[000002E8 - 000002EF]	Fintek Communications Port (COM4)
	[000002F8 - 000002FF]	Fintek Communications Port (COM2)
	[000003B0 - 000003BB]	Intel(R) Graphics Media Accelerator 3600 Series
	[000003C0 - 000003DF]	Intel(R) Graphics Media Accelerator 3600 Series
	[000003E8 - 000003EF]	Fintek Communications Port (COM3)
	[000003F8 - 000003FF]	Fintek Communications Port (COM1)
	[00000400 - 0000047F]	Motherboard resources
	[00000400 - 0000047F]	Motherboard resources
	[00000442 - 00000443]	Motherboard resources
	[000004D0 - 000004D1]	Motherboard resources
	[000004D0 - 000004D1]	Programmable interrupt controller
	[00000500 - 0000053F]	Motherboard resources
	[00000500 - 0000057F]	Motherboard resources
	[00000600 - 0000061F]	Motherboard resources
	[00000600 - 0000061F]	Motherboard resources
	[00000680 - 0000069F]	Motherboard resources

































	[000006A0 - 000006AF]	Motherboard resources
	[000006B0 - 000006EF]	Motherboard resources
	[00000D00 - 0000FFFF]	PCI bus
	[00001000 - 0000100F]	Motherboard resources
	[0000C000 - 0000CFFF]	Intel(R) N10/ICH7 Family PCI Express Root Port - 27D6
	[0000D000 - 0000D01F]	Fintek Pcie To Serial
	[0000D000 - 0000DFFF]	Intel(R) N10/ICH7 Family PCI Express Root Port - 27D4
	[0000D000 - 0000DFFF]	PCI standard PCI-to-PCI bridge
	[0000D000 - 0000DFFF]	PCI standard PCI-to-PCI bridge
	[0000D000 - 0000DFFF]	PCI standard PCI-to-PCI bridge
	[0000D000 - 0000DFFF]	PCI standard PCI-to-PCI bridge
	[0000D020 - 0000D03F]	Fintek Pcie To Serial
	[0000D040 - 0000D05F]	Fintek Pcie To Serial
	[0000D060 - 0000D07F]	Fintek Pcie To Serial
	[0000D080 - 0000D08F]	Fintek Pcie To Serial
	[0000E000 - 0000EFFF]	Intel(R) N10/ICH7 Family PCI Express Root Port - 27D0
	[0000F000 - 0000F01F]	Intel(R) N10/ICH7 Family SMBus Controller - 27DA
	[0000F020 - 0000F03F]	Intel(R) N10/ICH7 Family USB Universal Host Controller - 27CB
	[0000F040 - 0000F05F]	Intel(R) N10/ICH7 Family USB Universal Host Controller - 27CA
	[0000F060 - 0000F07F]	Intel(R) N10/ICH7 Family USB Universal Host Controller - 27C9
	[0000F080 - 0000F09F]	Intel(R) N10/ICH7 Family USB Universal Host Controller - 27C8
	[0000F0A0 - 0000F0AF]	Intel(R) N10/ICH7 Family Serial ATA Storage Controller - 27C0
	[0000F0B0 - 0000F0B3]	Intel(R) N10/ICH7 Family Serial ATA Storage Controller - 27C0
	[0000F0C0 - 0000F0C7]	Intel(R) N10/ICH7 Family Serial ATA Storage Controller - 27C0
	[0000F0D0 - 0000F0D3]	Intel(R) N10/ICH7 Family Serial ATA Storage Controller - 27C0
	[0000F0E0 - 0000F0E7]	Intel(R) N10/ICH7 Family Serial ATA Storage Controller - 27C0
	[0000F0F0 - 0000F0F7]	Intel(R) Graphics Media Accelerator 3600 Series
	[0000FFFF - 0000FFFF]	Motherboard resources
	[0000FFFF - 0000FFFF]	Motherboard resources

































B.2 Memory Address Map

































Address Range	Device Name
[00000000 - 00000FFF]	Motherboard resources
[00000000 - 00000FFF]	Motherboard resources
[00000000 - 00003FFF]	Motherboard resources
[000A0000 - 000BFFFF]	Intel(R) Graphics Media Accelerator 3600 Series
[000A0000 - 000BFFFF]	PCI bus
[000C0000 - 000DFFFF]	PCI bus
[000E0000 - 000EFFFF]	PCI bus
[000F0000 - 000FFFFF]	PCI bus
[7F800000 - 7FFFFFFF]	PCI bus
[80000000 - FEBFFFFFF]	PCI bus
[DFA00000 - DFAFFFFFF]	Intel(R) Graphics Media Accelerator 3600 Series
[DFB00000 - DFB1FFFF]	Intel(R) 82583V Gigabit Network Connection
[DFB00000 - DFBFFFFFF]	Intel(R) N10/ICH7 Family PCI Express Root Port - 27D6
[DFB20000 - DFB23FFF]	Intel(R) 82583V Gigabit Network Connection
[DFC00000 - DFC0000F]	Fintek Pcie To Serial
[DFC00000 - DFCFFFFFF]	Intel(R) N10/ICH7 Family PCI Express Root Port - 27D4
[DFC00000 - DFCFFFFFF]	PCI standard PCI-to-PCI bridge
[DFC00000 - DFCFFFFFF]	PCI standard PCI-to-PCI bridge
[DFC00000 - DFCFFFFFF]	PCI standard PCI-to-PCI bridge
[DFC00000 - DFCFFFFFF]	PCI standard PCI-to-PCI bridge
[DFD00000 - DFD01FFF]	Renesas Electronics USB 3.0 Host Controller
[DFD00000 - DFDFFFFFF]	Intel(R) N10/ICH7 Family PCI Express Root Port - 27D2
[DFE00000 - DFE1FFFF]	Intel(R) 82583V Gigabit Network Connection #2
[DFE00000 - DFEFFFFFF]	Intel(R) N10/ICH7 Family PCI Express Root Port - 27D0
[DFE20000 - DFE23FFF]	Intel(R) 82583V Gigabit Network Connection #2
[DFF00000 - DFF03FFF]	High Definition Audio Controller
[DFF04000 - DFF043FF]	Intel(R) N10/ICH7 Family Serial ATA Storage Controller - 27C0
[DFF05000 - DFF053FF]	Intel(R) N10/ICH7 Family USB2 Enhanced Host Controller - 27CC
[E0000000 - EFFFFFFF]	System board
[FEC00000 - FEC00FFF]	Motherboard resources
[FED00000 - FED003FF]	High precision event timer
[FED14000 - FED19FFF]	System board
[FED1C000 - FED1FFFF]	Motherboard resources
[FED1C000 - FED1FFFF]	Motherboard resources
[FED20000 - FED8FFFF]	Motherboard resources
[FED45000 - FED8FFFF]	Motherboard resources
[FEE00000 - FEE00FFF]	Motherboard resources
[FF000000 - FFFFFFFF]	Intel(R) 82802 Firmware Hub Device
[FF000000 - FFFFFFFF]	Intel(R) 82802 Firmware Hub Device
[FFC00000 - FFFFFFFF]	Motherboard resources

B.3 IRQ Mapping Chart

Interrupt request (IRQ)	
(ISA) 0x00000000 (00)	System timer
(ISA) 0x00000003 (03)	Fintek Communications Port (COM2)
(ISA) 0x00000004 (04)	Fintek Communications Port (COM1)
(ISA) 0x00000008 (08)	System CMOS/real time clock
(ISA) 0x0000000A (10)	Fintek Communications Port (COM4)
(ISA) 0x0000000B (11)	Fintek Communications Port (COM3)
(ISA) 0x0000000D (13)	Numeric data processor
(ISA) 0x00000051 (81)	Microsoft ACPI-Compliant System
(ISA) 0x00000052 (82)	Microsoft ACPI-Compliant System
(ISA) 0x00000053 (83)	Microsoft ACPI-Compliant System
(ISA) 0x00000054 (84)	Microsoft ACPI-Compliant System
(ISA) 0x00000055 (85)	Microsoft ACPI-Compliant System
(ISA) 0x00000056 (86)	Microsoft ACPI-Compliant System
(ISA) 0x00000057 (87)	Microsoft ACPI-Compliant System
(ISA) 0x00000058 (88)	Microsoft ACPI-Compliant System
(ISA) 0x00000059 (89)	Microsoft ACPI-Compliant System
(ISA) 0x0000005A (90)	Microsoft ACPI-Compliant System
(ISA) 0x0000005B (91)	Microsoft ACPI-Compliant System
(ISA) 0x0000005C (92)	Microsoft ACPI-Compliant System
(ISA) 0x0000005D (93)	Microsoft ACPI-Compliant System
(ISA) 0x0000005E (94)	Microsoft ACPI-Compliant System
(ISA) 0x0000005F (95)	Microsoft ACPI-Compliant System
(ISA) 0x00000060 (96)	Microsoft ACPI-Compliant System
(ISA) 0x00000061 (97)	Microsoft ACPI-Compliant System
(ISA) 0x00000062 (98)	Microsoft ACPI-Compliant System
(ISA) 0x00000063 (99)	Microsoft ACPI-Compliant System
(ISA) 0x00000064 (100)	Microsoft ACPI-Compliant System
(ISA) 0x00000065 (101)	Microsoft ACPI-Compliant System
(ISA) 0x00000066 (102)	Microsoft ACPI-Compliant System
(ISA) 0x00000067 (103)	Microsoft ACPI-Compliant System
(ISA) 0x00000068 (104)	Microsoft ACPI-Compliant System
(ISA) 0x00000069 (105)	Microsoft ACPI-Compliant System

 (ISA) 0x0000006A (106)	Microsoft ACPI-Compliant System
 (ISA) 0x0000006B (107)	Microsoft ACPI-Compliant System
 (ISA) 0x0000006C (108)	Microsoft ACPI-Compliant System
 (ISA) 0x0000006D (109)	Microsoft ACPI-Compliant System
 (ISA) 0x0000006E (110)	Microsoft ACPI-Compliant System
 (ISA) 0x0000006F (111)	Microsoft ACPI-Compliant System
 (ISA) 0x00000070 (112)	Microsoft ACPI-Compliant System
 (ISA) 0x00000071 (113)	Microsoft ACPI-Compliant System
 (ISA) 0x00000072 (114)	Microsoft ACPI-Compliant System
 (ISA) 0x00000073 (115)	Microsoft ACPI-Compliant System
 (ISA) 0x00000074 (116)	Microsoft ACPI-Compliant System
 (ISA) 0x00000075 (117)	Microsoft ACPI-Compliant System
 (ISA) 0x00000076 (118)	Microsoft ACPI-Compliant System
 (ISA) 0x00000077 (119)	Microsoft ACPI-Compliant System
 (ISA) 0x00000078 (120)	Microsoft ACPI-Compliant System
 (ISA) 0x00000079 (121)	Microsoft ACPI-Compliant System
 (ISA) 0x0000007A (122)	Microsoft ACPI-Compliant System
 (ISA) 0x0000007B (123)	Microsoft ACPI-Compliant System
 (ISA) 0x0000007C (124)	Microsoft ACPI-Compliant System
 (ISA) 0x0000007D (125)	Microsoft ACPI-Compliant System
 (ISA) 0x0000007E (126)	Microsoft ACPI-Compliant System
 (ISA) 0x0000007F (127)	Microsoft ACPI-Compliant System
 (ISA) 0x00000080 (128)	Microsoft ACPI-Compliant System
 (ISA) 0x00000081 (129)	Microsoft ACPI-Compliant System
 (ISA) 0x00000082 (130)	Microsoft ACPI-Compliant System
 (ISA) 0x00000083 (131)	Microsoft ACPI-Compliant System
 (ISA) 0x00000084 (132)	Microsoft ACPI-Compliant System
 (ISA) 0x00000085 (133)	Microsoft ACPI-Compliant System
 (ISA) 0x00000086 (134)	Microsoft ACPI-Compliant System
 (ISA) 0x00000087 (135)	Microsoft ACPI-Compliant System
 (ISA) 0x00000088 (136)	Microsoft ACPI-Compliant System
 (ISA) 0x00000089 (137)	Microsoft ACPI-Compliant System
 (ISA) 0x0000008A (138)	Microsoft ACPI-Compliant System

 (ISA) 0x0000008B (139)	Microsoft ACPI-Compliant System
 (ISA) 0x0000008C (140)	Microsoft ACPI-Compliant System
 (ISA) 0x0000008D (141)	Microsoft ACPI-Compliant System
 (ISA) 0x0000008E (142)	Microsoft ACPI-Compliant System
 (ISA) 0x0000008F (143)	Microsoft ACPI-Compliant System
 (ISA) 0x00000090 (144)	Microsoft ACPI-Compliant System
 (ISA) 0x00000091 (145)	Microsoft ACPI-Compliant System
 (ISA) 0x00000092 (146)	Microsoft ACPI-Compliant System
 (ISA) 0x00000093 (147)	Microsoft ACPI-Compliant System
 (ISA) 0x00000094 (148)	Microsoft ACPI-Compliant System
 (ISA) 0x00000095 (149)	Microsoft ACPI-Compliant System
 (ISA) 0x00000096 (150)	Microsoft ACPI-Compliant System
 (ISA) 0x00000097 (151)	Microsoft ACPI-Compliant System
 (ISA) 0x00000098 (152)	Microsoft ACPI-Compliant System
 (ISA) 0x00000099 (153)	Microsoft ACPI-Compliant System
 (ISA) 0x0000009A (154)	Microsoft ACPI-Compliant System
 (ISA) 0x0000009B (155)	Microsoft ACPI-Compliant System
 (ISA) 0x0000009C (156)	Microsoft ACPI-Compliant System
 (ISA) 0x0000009D (157)	Microsoft ACPI-Compliant System
 (ISA) 0x0000009E (158)	Microsoft ACPI-Compliant System
 (ISA) 0x0000009F (159)	Microsoft ACPI-Compliant System
 (ISA) 0x000000A0 (160)	Microsoft ACPI-Compliant System
 (ISA) 0x000000A1 (161)	Microsoft ACPI-Compliant System
 (ISA) 0x000000A2 (162)	Microsoft ACPI-Compliant System
 (ISA) 0x000000A3 (163)	Microsoft ACPI-Compliant System
 (ISA) 0x000000A4 (164)	Microsoft ACPI-Compliant System
 (ISA) 0x000000A5 (165)	Microsoft ACPI-Compliant System
 (ISA) 0x000000A6 (166)	Microsoft ACPI-Compliant System
 (ISA) 0x000000A7 (167)	Microsoft ACPI-Compliant System
 (ISA) 0x000000A8 (168)	Microsoft ACPI-Compliant System
 (ISA) 0x000000A9 (169)	Microsoft ACPI-Compliant System
 (ISA) 0x000000AA (170)	Microsoft ACPI-Compliant System
 (ISA) 0x000000AB (171)	Microsoft ACPI-Compliant System

	(ISA) 0x000000AC (172)	Microsoft ACPI-Compliant System
	(ISA) 0x000000AD (173)	Microsoft ACPI-Compliant System
	(ISA) 0x000000AE (174)	Microsoft ACPI-Compliant System
	(ISA) 0x000000AF (175)	Microsoft ACPI-Compliant System
	(ISA) 0x000000B0 (176)	Microsoft ACPI-Compliant System
	(ISA) 0x000000B1 (177)	Microsoft ACPI-Compliant System
	(ISA) 0x000000B2 (178)	Microsoft ACPI-Compliant System
	(ISA) 0x000000B3 (179)	Microsoft ACPI-Compliant System
	(ISA) 0x000000B4 (180)	Microsoft ACPI-Compliant System
	(ISA) 0x000000B5 (181)	Microsoft ACPI-Compliant System
	(ISA) 0x000000B6 (182)	Microsoft ACPI-Compliant System
	(ISA) 0x000000B7 (183)	Microsoft ACPI-Compliant System
	(ISA) 0x000000B8 (184)	Microsoft ACPI-Compliant System
	(ISA) 0x000000B9 (185)	Microsoft ACPI-Compliant System
	(ISA) 0x000000BA (186)	Microsoft ACPI-Compliant System
	(ISA) 0x000000BB (187)	Microsoft ACPI-Compliant System
	(ISA) 0x000000BC (188)	Microsoft ACPI-Compliant System
	(ISA) 0x000000BD (189)	Microsoft ACPI-Compliant System
	(ISA) 0x000000BE (190)	Microsoft ACPI-Compliant System
	(PCI) 0x00000005 (05)	Intel(R) N10/ICH7 Family SMBus Controller - 27DA
	(PCI) 0x00000010 (16)	Intel(R) N10/ICH7 Family PCI Express Root Port - 27D0
	(PCI) 0x00000010 (16)	Intel(R) N10/ICH7 Family USB Universal Host Controller - 27CB
	(PCI) 0x00000011 (17)	Intel(R) N10/ICH7 Family PCI Express Root Port - 27D2
	(PCI) 0x00000011 (17)	PCI standard PCI-to-PCI bridge
	(PCI) 0x00000011 (17)	PCI standard PCI-to-PCI bridge
	(PCI) 0x00000011 (17)	PCI standard PCI-to-PCI bridge
	(PCI) 0x00000012 (18)	Intel(R) N10/ICH7 Family PCI Express Root Port - 27D4
	(PCI) 0x00000012 (18)	Intel(R) N10/ICH7 Family USB Universal Host Controller - 27CA
	(PCI) 0x00000012 (18)	PCI standard PCI-to-PCI bridge
	(PCI) 0x00000013 (19)	Communications Port (COM10)
	(PCI) 0x00000013 (19)	Communications Port (COM11)
	(PCI) 0x00000013 (19)	Communications Port (COM12)
	(PCI) 0x00000013 (19)	Communications Port (COM13)

(PCI) 0x00000013 (19)	Communications Port (COM13)
(PCI) 0x00000013 (19)	Communications Port (COM13)
(PCI) 0x00000013 (19)	Communications Port (COM13)
(PCI) 0x00000013 (19)	Communications Port (COM5)
(PCI) 0x00000013 (19)	Communications Port (COM6)
(PCI) 0x00000013 (19)	Communications Port (COM7)
(PCI) 0x00000013 (19)	Communications Port (COM8)
(PCI) 0x00000013 (19)	Communications Port (COM9)
(PCI) 0x00000013 (19)	Fintek Pcie To Serial
(PCI) 0x00000013 (19)	Intel(R) N10/ICH7 Family PCI Express Root Port - 27D6
(PCI) 0x00000013 (19)	Intel(R) N10/ICH7 Family Serial ATA Storage Controller - 27C0
(PCI) 0x00000013 (19)	Intel(R) N10/ICH7 Family USB Universal Host Controller - 27C9
(PCI) 0x00000013 (19)	PCI standard PCI-to-PCI bridge
(PCI) 0x00000013 (19)	PCI standard PCI-to-PCI bridge
(PCI) 0x00000016 (22)	High Definition Audio Controller
(PCI) 0x00000017 (23)	Intel(R) N10/ICH7 Family USB Universal Host Controller - 27C8
(PCI) 0x00000017 (23)	Intel(R) N10/ICH7 Family USB2 Enhanced Host Controller - 27CC
(PCI) 0xFFFFFFFF1 (-15)	Intel(R) 82583V Gigabit Network Connection
(PCI) 0xFFFFFFFF2 (-14)	Renesas Electronics USB 3.0 Host Controller
(PCI) 0xFFFFFFFF3 (-13)	Renesas Electronics USB 3.0 Host Controller
(PCI) 0xFFFFFFFF4 (-12)	Renesas Electronics USB 3.0 Host Controller
(PCI) 0xFFFFFFFF5 (-11)	Renesas Electronics USB 3.0 Host Controller
(PCI) 0xFFFFFFFF6 (-10)	Renesas Electronics USB 3.0 Host Controller
(PCI) 0xFFFFFFFF7 (-9)	Renesas Electronics USB 3.0 Host Controller
(PCI) 0xFFFFFFFF8 (-8)	Renesas Electronics USB 3.0 Host Controller
(PCI) 0xFFFFFFFF9 (-7)	Renesas Electronics USB 3.0 Host Controller
(PCI) 0xFFFFFFFFFA (-6)	Intel(R) 82583V Gigabit Network Connection #2
(PCI) 0xFFFFFFFFFB (-5)	Intel(R) Graphics Media Accelerator 3600 Series
(PCI) 0xFFFFFFFFFC (-4)	PCI standard PCI-to-PCI bridge
(PCI) 0xFFFFFFFFFD (-3)	PCI standard PCI-to-PCI bridge
(PCI) 0xFFFFFFFFFE (-2)	PCI standard PCI-to-PCI bridge

B.4 DMA Channel Assignments

test-PC
Direct memory access (DMA)
4 Direct memory access controller

Appendix

C

Programming the Digital I/O

C.1 DIO Programming

1. General Description

F75113 is a low power general purpose IO chip providing 40 GPIO. Level or pulse mode can be programmed by registers so all GPIO can be programmed to logic one, zero, high pulse or low pulse. GPIO0X~GPIO2X can be programmed to be power LED. F75113 includes two sets of watchdog timer for system reset. Besides, two power-down modes (Manual or Smart) can be selected to save power and control the total consumption under 10uA, so F75113 can fit the requirement of mobile device such as PDA or cell phone.

2. Access Interface

The F75113 provides three auto-detected access interfaces, LPC, SMBus or SPI, to read/write internal registers. In LPC interface, the default address of Configuration Register I/O port is 2Eh. When user writes data 10h to LPC configuration register 27h, the address of Configuration Register I/O port will be 4Eh. In SMBus interface, Serial Bus address default value is 6Eh (0110_1110). Another SPI interface only care the least eight bits (LSB) of 24 bits address. SPI interface write register by 02h instruction (Page Program) and read register by 03h instruction (Read Data). Also SPI interface supported byte write/read function.

Besides, the pin 46, 47, 48, 1, 2, 3, 4 are multi-function pins. If user want to access internal register by LPC interface, the F75113 will

only supported 39 GPIO function and the pin 4 won't be used for GPIO function. If user wants to access internal register by SMBus interface, the pin 48, 1, 2, 3 must be set internal pull-high with 10K Ω . When user don't use the pin 4 (GPIO function), the pin will must be set internal pull-high. In SPI interface, the pin 2, 3 must be set internal pull-high with 10K Ω . Also, the pin 4 will be selectively set internal pull-high with 10K Ω by user.

3. Register Description

When users access internal registers by LPC interface, the configuration register will be used to control the behavior of the corresponding devices. To configure the register, using the index port to select the index and then writing data port to alter the parameters. The default index port and data port are 2Eh and 2Fh respectively. Write data 10h in index 27h of global control register to change the default value to 4Eh/4Fh. To enable configuration, the entry key 50h must be written to the index port. To disable configuration, write exit key AAh to the index port. Following is an example to enable configuration and disable configuration by using debug.

```
-o 2e 50
```

```
-o 2e 50 (enable configuration)
```

```
-o 2e aa (disable configuration)
```

The Following is a register map (total devices) grouped in hexadecimal address order, which shows a summary of all registers

and their default value. Please refer each device chapter if you want more detail information.

4. GPIO Function

The F75113 with GPIO0X~GPIO4X General Purpose I/O port is composed of independent I/O pins controlled and controls multi-pin function by Index 02~06h register. Each of GPIO group has input capability, output (push-pull and open-drain) capability, internal pull-up resistor with 10K Ω . Also F75113 has GPIO2x groups with the Low Level Input, LED, SMI and RSTOUT function. Please check below table how to select the GPIO multi-function pin that user wants.

Group	Pin	Function1	Condition	Function2	Condition	Function3	Condition	Function4	Condition	Pull Cap
GPIO0	0 28	GPIO00	GPIO00_MD=0	LED00	GPIO00_MD=1	SMI	GPIO00_MD=2	RSTOUT1	GPIO00_MD=3	UP
	1 27	GPIO01	GPIO01_MD=0	LED01	GPIO01_MD=1	SMI	GPIO01_MD=2	RSTOUT1	GPIO01_MD=3	UP
	2 26	GPIO02	GPIO02_MD=0	LED02	GPIO02_MD=1	SMI	GPIO02_MD=2	RSTOUT1	GPIO02_MD=3	UP
	3 25	GPIO03	GPIO03_MD=0	LED03	GPIO03_MD=1	SMI	GPIO03_MD=2	RSTOUT1	GPIO03_MD=3	UP
	4 24	GPIO04	GPIO04_MD=0	LED04	GPIO04_MD=1	SMI	GPIO04_MD=2	RSTOUT2	GPIO04_MD=3	UP
	5 23	GPIO05	GPIO05_MD=0	LED05	GPIO05_MD=1	SMI	GPIO05_MD=2	RSTOUT2	GPIO05_MD=3	UP
	6 22	GPIO06	GPIO06_MD=0	LED06	GPIO06_MD=1	SMI	GPIO06_MD=2	RSTOUT2	GPIO06_MD=3	UP
GPIO1	7 21	GPIO07	GPIO07_MD=0	LED07	GPIO07_MD=1	SMI	GPIO07_MD=2	RSTOUT2	GPIO07_MD=3	UP
	0 40	GPIO10	GPIO10_MD=0	LED10	GPIO10_MD=1					UP
	1 39	GPIO11	GPIO11_MD=0	LED11	GPIO11_MD=1					UP
	2 38	GPIO12	GPIO12_MD=0	LED12	GPIO12_MD=1					UP
	3 37	GPIO13	GPIO13_MD=0	LED13	GPIO13_MD=1					UP
	4 36	GPIO14	GPIO14_MD=0	LED14	GPIO14_MD=1					UP
	5 35	GPIO15	GPIO15_MD=0	LED15	GPIO15_MD=1					UP
GPIO2	6 34	GPIO16	GPIO16_MD=0	LED16	GPIO16_MD=1					UP
	7 33	GPIO17	GPIO17_MD=0	LED17	GPIO17_MD=1					UP
	0 16	GPIO20/LV_IN	GPIO20_MD=0	LED20	GPIO20_MD=1					UP
	1 15	GPIO21/LV_IN	GPIO21_MD=0	LED21	GPIO21_MD=1					UP
	2 14	GPIO22/LV_IN	GPIO22_MD=0	LED22	GPIO22_MD=1					UP
	3 13	GPIO23/LV_IN	GPIO23_MD=0	LED23	GPIO23_MD=1					UP
	4 12	GPIO24/LV_IN	GPIO24_MD=0	LED24	GPIO24_MD=1					UP
GPIO3	5 11	GPIO25/LV_IN	GPIO25_MD=0	LED25	GPIO25_MD=1					UP
	6 10	GPIO26/LV_IN	GPIO26_MD=0	LED26	GPIO26_MD=1					UP
	7 09	GPIO27/LV_IN	GPIO27_MD=0	LED27	GPIO27_MD=1					UP
	0 32	GPIO30								UP
	1 31	GPIO31								UP
	2 30	GPIO32								UP
	3 29	GPIO33								UP
GPIO4	4 20	GPIO34								UP
	5 19	GPIO35								UP
	6 18	GPIO36								UP
	7 17	GPIO37								UP
	0 45	GPIO40								UP
	1 44	GPIO41								UP
	2 43	GPIO42								UP
GPIO4	3 42	GPIO43								UP
	4 07	GPIO44								UP
	5 06	GPIO45								UP
	6 05	SIRQ/GPIO46	Can't use GPIO46 under LPC interface							UP
	7 04	GPIO47	Can't use GPIO47 under LPC interface							UP

5. Hi-Safe setting DIO

AAEON Hi-Safe
An ASUS assoc. co.

Dio

Dio Current State Group 1

	Dio1	Dio2	Dio3	Dio4	Dio5	Dio6	Dio7	Dio8
Mode								
Value								

Dio Setting

	Dio1	Dio2	Dio3	Dio4	Dio5	Dio6	Dio7	Dio8
Mode	Output	Output	Output	Output	Output	Output	Output	Output
	Input	Input	Input	Input	Input	Input	Input	Input
Value	Low	Low	Low	Low	Low	Low	Low	Low
	High	High	High	High	High	High	High	High

AAEON *An ASUS assoc. co.* **Hi-Safe**

Dio

Dio Current State Group 2

	Dio9	Dio10	Dio11	Dio12	Dio13	Dio14	Dio15	Dio16
Mode								
Value								

Dio Setting

	Dio9	Dio10	Dio11	Dio12	Dio13	Dio14	Dio15	Dio16
Mode	Output Input	Output Input	Output Input	Output Input	Output Input	Output Input	Output Input	Output Input
Value	Low High	Low High	Low High	Low High	Low High	Low High	Low High	Low High

Set

AAEON *Hi-Safe*
An **ASUS** assoc. co.

Dio

Dio Current State Group 3 ▾

	Dio17	Dio18	Dio19	Dio20	Dio21	Dio22	Dio23	Dio24
Mode								
Value								

Dio Setting

	Dio17	Dio18	Dio19	Dio20	Dio21	Dio22	Dio23	Dio24
Mode	Output Input	Output Input	Output Input	Output Input	Output Input	Output Input	Output Input	Output Input
Value	Low High	Low High	Low High	Low High	Low High	Low High	Low High	Low High

Set

A4EON *Hi-Safe*
An ASUS assoc. co.

Dio

Dio Current State Group 4 ▾

	Dio25	Dio26	Dio27	Dio28	Dio29	Dio30	Dio31	Dio32
Mode								
Value								

Dio Setting

	Dio25	Dio26	Dio27	Dio28	Dio29	Dio30	Dio31	Dio32
Mode	Output Input	Output Input	Output Input	Output Input	Output Input	Output Input	Output Input	Output Input
Value	Low High	Low High	Low High	Low High	Low High	Low High	Low High	Low High

Set